



System Administration Guide: Basic Administration

Sun Microsystems, Inc.
4150 Network Circle
Santa Clara, CA 95054
U.S.A.

Part No: 817-2874
December 2003

Copyright 2003 Sun Microsystems, Inc. 4150 Network Circle, Santa Clara, CA 95054 U.S.A. All rights reserved.

This product or document is protected by copyright and distributed under licenses restricting its use, copying, distribution, and decompilation. No part of this product or document may be reproduced in any form by any means without prior written authorization of Sun and its licensors, if any. Third-party software, including font technology, is copyrighted and licensed from Sun suppliers.

Parts of the product may be derived from Berkeley BSD systems, licensed from the University of California. UNIX is a registered trademark in the U.S. and other countries, exclusively licensed through X/Open Company, Ltd.

Sun, Sun Microsystems, the Sun logo, docs.sun.com, AnswerBook, AnswerBook2, AutoClient, JumpStart, Sun Ray, Sun Blade, PatchPro, Sun Cobalt, SunOS, Solstice, Solstice AdminSuite, Solstice DiskSuite, Solaris Solve, Java, JavaStation, OpenWindows, NFS, iPlanet, Netra and Solaris are trademarks, registered trademarks, or service marks of Sun Microsystems, Inc. in the U.S. and other countries. All SPARC trademarks are used under license and are trademarks or registered trademarks of SPARC International, Inc. in the U.S. and other countries. Products bearing SPARC trademarks are based upon an architecture developed by Sun Microsystems, Inc. DLT is claimed as a trademark of Quantum Corporation in the United States and other countries.

The OPEN LOOK and Sun™ Graphical User Interface was developed by Sun Microsystems, Inc. for its users and licensees. Sun acknowledges the pioneering efforts of Xerox in researching and developing the concept of visual or graphical user interfaces for the computer industry. Sun holds a non-exclusive license from Xerox to the Xerox Graphical User Interface, which license also covers Sun's licensees who implement OPEN LOOK GUIs and otherwise comply with Sun's written license agreements.

Federal Acquisitions: Commercial Software—Government Users Subject to Standard License Terms and Conditions.

DOCUMENTATION IS PROVIDED "AS IS" AND ALL EXPRESS OR IMPLIED CONDITIONS, REPRESENTATIONS AND WARRANTIES, INCLUDING ANY IMPLIED WARRANTY OF MERCHANTABILITY, FITNESS FOR A PARTICULAR PURPOSE OR NON-INFRINGEMENT, ARE DISCLAIMED, EXCEPT TO THE EXTENT THAT SUCH DISCLAIMERS ARE HELD TO BE LEGALLY INVALID.

Copyright 2003 Sun Microsystems, Inc. 4150 Network Circle, Santa Clara, CA 95054 U.S.A. Tous droits réservés.

Ce produit ou document est protégé par un copyright et distribué avec des licences qui en restreignent l'utilisation, la copie, la distribution, et la décompilation. Aucune partie de ce produit ou document ne peut être reproduite sous aucune forme, par quelque moyen que ce soit, sans l'autorisation préalable et écrite de Sun et de ses bailleurs de licence, s'il y en a. Le logiciel détenu par des tiers, et qui comprend la technologie relative aux polices de caractères, est protégé par un copyright et licencié par des fournisseurs de Sun.

Des parties de ce produit pourront être dérivées du système Berkeley BSD licenciés par l'Université de Californie. UNIX est une marque déposée aux Etats-Unis et dans d'autres pays et licenciée exclusivement par X/Open Company, Ltd.

Sun, Sun Microsystems, le logo Sun, docs.sun.com, AnswerBook, AnswerBook2, AutoClient, JumpStart, Sun Ray, Sun Blade, PatchPro, Sun Cobalt, SunOS, Solstice, Solstice AdminSuite, Solstice DiskSuite, Solaris Solve, Java, JavaStation, DeskSet, OpenWindows, NFS et Solaris sont des marques de fabrique ou des marques déposées, ou marques de service, de Sun Microsystems, Inc. aux Etats-Unis et dans d'autres pays. Toutes les marques SPARC sont utilisées sous licence et sont des marques de fabrique ou des marques déposées de SPARC International, Inc. aux Etats-Unis et dans d'autres pays. Les produits portant les marques SPARC sont basés sur une architecture développée par Sun Microsystems, Inc. Quantum Corporation réclame DLT comme sa marque de fabrique aux Etats-Unis et dans d'autres pays.

L'interface d'utilisation graphique OPEN LOOK et Sun™ a été développée par Sun Microsystems, Inc. pour ses utilisateurs et licenciés. Sun reconnaît les efforts de pionniers de Xerox pour la recherche et le développement du concept des interfaces d'utilisation visuelle ou graphique pour l'industrie de l'informatique. Sun détient une licence non exclusive de Xerox sur l'interface d'utilisation graphique Xerox, cette licence couvrant également les licenciés de Sun qui mettent en place l'interface d'utilisation graphique OPEN LOOK et qui en outre se conforment aux licences écrites de Sun.

CETTE PUBLICATION EST FOURNIE "EN L'ETAT" ET AUCUNE GARANTIE, EXPRESSE OU IMPLICITE, N'EST ACCORDEE, Y COMPRIS DES GARANTIES CONCERNANT LA VALEUR MARCHANDE, L'APTITUDE DE LA PUBLICATION A REPOUDRE A UNE UTILISATION PARTICULIERE, OU LE FAIT QU'ELLE NE SOIT PAS CONTREFAISANTE DE PRODUIT DE TIERS. CE DENI DE GARANTIE NE S'APPLIQUERAIT PAS, DANS LA MESURE OU IL SERAIT TENU JURIDIQUEMENT NUL ET NON AVENU.



030826@6671



Contents

Preface	27
1 Solaris Management Tools (Roadmap)	31
What's New in Solaris Management Tools?	31
Matrix of Solaris Management Tools Support	32
Feature Descriptions for Solaris 9 Management Tools	33
Feature Descriptions for Solaris 8 Management Tools	34
Feature Descriptions for Previous Solaris Management Tools	36
Availability Solaris Management Commands	36
Solaris 9 System Management Commands	37
Solaris 8 System Management Commands	38
Descriptions for Previous Solaris Management Commands	38
For More Information About Solaris Management Tools	39
2 Working With the Solaris Management Console (Tasks)	41
Solaris Management Console (Overview)	41
What Is the Solaris Management Console?	41
Solaris Management Console Tools	42
Why Use the Solaris Management Console?	44
Organization of the Solaris Management Console	45
Changing the Solaris Management Console Window	46
Solaris Management Console Documentation	46
How Much Role-Based Access Control?	46
Becoming Superuser (root) or Assuming a Role	48
▼ How to Become Superuser (root) or Assume a Role	48

Using the Solaris Management Tools With RBAC (Task Map)	50
If You Are the First to Log In to the Console	51
Creating the Primary Administrator Role	51
▼ How to Create the First Role (Primary Administrator)	53
▼ How to Assume the Primary Administrator Role	53
Starting the Solaris Management Console	54
▼ How to Start the Console as Superuser or as a Role	54
Using the Solaris Management Tools in a Name Service Environment (Task Map)	56
RBAC Security Files	56
Prerequisites for Using the Solaris Management Console in a Name Service Environment	58
Management Scope	58
The <code>/etc/nsswitch.conf</code> File	58
▼ How to Create a Toolbox for a Specific Environment	59
▼ How to Add a Tool to a Toolbox	60
▼ How to Start the Solaris Management Console in a Name Service Environment	61
Adding Tools to the Solaris Management Console	62
▼ How to Add a Legacy Tool to a Toolbox	62
▼ How to Install an Unbundled Tool	62
Troubleshooting the Solaris Management Console	63
▼ How to Troubleshoot the Solaris Management Console	63
3 Managing Users and Groups Topics	65
4 Managing User Accounts and Groups (Overview)	67
What's New in Managing Users and Groups?	67
Solaris Management Console Tools Suite	68
Solaris Directory Services	68
Managing Users and Resources With Projects	68
What Are User Accounts and Groups?	69
Guidelines for Managing User Accounts	70
Name Services	70
User (Login) Names	70
User ID Numbers	71
Passwords	73
Password Aging	74

Home Directories	75
User's Work Environment	75
Guidelines for Managing Groups	76
Tools for Managing User Accounts and Groups	77
What You Can Do With Solaris User Management Tools	78
Managing Home Directories With the Solaris Management Console	81
Modify User Accounts	81
Delete User Accounts	82
Add Customized User Initialization Files	82
Administer Passwords	82
Disable User Accounts	83
Where User Account and Group Information Is Stored	83
Fields in the <code>passwd</code> File	83
Fields in the <code>shadow</code> File	85
Fields in the <code>group</code> File	86
Customizing a User's Work Environment	88
Using Site Initialization Files	90
Avoid Local System References	90
Shell Features	91
Shell Environment	91
The <code>PATH</code> Variable	94
Locale Variables	95
Default File Permissions (<code>umask</code>)	96
Examples of User and Site Initialization Files	97
Example—Site Initialization File	98
5 Managing User Accounts and Groups (Tasks)	101
Setting Up User Accounts (Task Map)	101
How to Gather User Information	102
▼ How to Customize User Initialization Files	103
▼ How to Add a Group with the Solaris Management Console's Groups Tool	105
▼ How to Add a User With the Solaris Management Console's Users Tool	106
Example—Adding a User With the Solaris Management Console's Groups Tool	106
How to Add Groups and Users With CLI Tools	107
▼ How to Share a User's Home Directory	107
▼ How to Mount a User's Home Directory	109

Maintaining User Accounts (Task Map)	110
Solaris User Registration	111
Accessing Solaris Solve	111
Troubleshooting Solaris User Registration Problems	112
▼ How to Restart Solaris User Registration	113
▼ How To Disable User Registration	113
6 Managing Server and Client Support Topics	115
7 Managing Server and Client Support (Overview)	117
What's New in Server and Client Management?	117
Diskless Client Support	117
Where to Find Server and Client Tasks	118
What Are Servers, Clients, and Appliances?	118
What Does Client Support Mean?	119
Overview of System Types	120
Servers	120
Standalone Systems	121
Diskless Clients	121
AutoClient Systems	122
Appliances	122
Guidelines for Choosing System Types	122
Diskless Client Management Overview	123
OS Server and Diskless Client Support Information	124
Diskless Client Management Features	124
Disk Space Requirements for OS Servers	127
8 Managing Diskless Clients (Tasks)	129
Managing Diskless Clients (Task Map)	129
Managing Diskless Clients	130
▼ How to Prepare for Adding Diskless Clients	132
▼ How to Add OS Services For Diskless Client Support	133
▼ How to Add a Diskless Client	135
▼ How to Boot a Diskless Client	136
▼ How to Delete Diskless Client Support	137
▼ How to Delete OS Services for Diskless Clients	137
Patching Diskless Client OS Services	138

	Displaying OS Patches for Diskless Clients	138
	▼ How to Add an OS Patch for a Diskless Client	139
	Troubleshooting Diskless Client Problems	141
9	Shutting Down and Booting a System Topics	145
10	Shutting Down and Booting a System (Overview)	147
	What's New in Shutting Down and Booting a System?	147
	PXE Network Boot	148
	Where to Find Shutting Down and Booting Tasks	148
	Shutting Down and Booting Terminology	149
	Guidelines for Shutting Down a System	149
	Guidelines for Booting a System	150
	Booting a System From the Network	150
	When to Shut Down a System	151
	When to Boot a System	152
11	Run Levels and Boot Files (Tasks)	155
	Run Levels	155
	How to Determine a System's Run Level	156
	The /etc/inittab File	157
	Example—Default inittab File	158
	What Happens When the System Is Brought to Run Level 3	159
	Run Control Scripts	160
	Run Control Script Summaries	161
	Using a Run Control Script to Stop or Start Services	165
	▼ How to Use a Run Control Script to Stop or Start a Service	165
	Adding a Run Control Script	166
	▼ How to Add a Run Control Script	166
	Disabling a Run Control Script	167
	▼ How to Disable a Run Control Script	167
	x86: Boot Files	167
12	Shutting Down a System (Tasks)	169
	Shutting Down the System	169
	System Shutdown Commands	170

	User Notification of System Down Time	171
	▼ How to Determine Who Is Logged in to a System	171
	▼ How to Shut Down a Server	171
	▼ How to Shut Down a Standalone System	175
	Turning Off Power to All Devices	176
	▼ How to Turn Off Power to All Devices	177
13	SPARC: Booting a System (Tasks)	179
	SPARC: Booting a System (Task Map)	179
	SPARC: Using the Boot PROM	181
	SPARC: How to Find the PROM Revision for a System	181
	▼ SPARC: How to Identify Devices on a System	181
	▼ SPARC: How to Change the Default Boot Device	183
	SPARC: How to Reset the System	185
	SPARC: Booting a System	185
	▼ SPARC: How to Boot a System to Run Level 3 (Multiuser Level)	186
	▼ SPARC: How to Boot a System to Run Level S (Single-User Level)	187
	▼ SPARC: How to Boot a System Interactively	188
	▼ SPARC: How to Boot a System From the Network	189
	▼ SPARC: How to Stop the System for Recovery Purposes	190
	▼ SPARC: How to Boot a System for Recovery Purposes	191
	▼ SPARC: How to Boot the System With the Kernel Debugger (kadb)	193
	SPARC: Forcing a Crash Dump and Rebooting the System	194
	▼ SPARC: How to Force a Crash Dump and Reboot the System	194
14	x86: Booting a System (Tasks)	197
	x86: Booting a System (Task Map)	197
	x86: Booting the Solaris Device Configuration Assistant	198
	▼ x86: How to Boot the Solaris Device Configuration Assistant	199
	x86: Booting a System	199
	▼ x86: How to Boot a System to Run Level 3 (Multiuser Level)	199
	▼ x86: How to Boot a System to Run Level S (Single-User Level)	200
	▼ x86: How to Boot a System Interactively	201
	▼ x86: How to Boot a System From the Network	203
	▼ x86: How to Stop a System for Recovery Purposes	204
	▼ x86: How to Boot a System for Recovery Purposes	204
	▼ x86: How to Boot a System With the Kernel Debugger (kadb)	209

	x86: Forcing a Crash Dump and Rebooting the System	210
	▼ x86: How to Force a Crash Dump and Reboot the System	210
15	The Boot Process (Reference)	213
	SPARC: The Boot PROM	213
	SPARC: The Boot Process	214
	x86: The PC BIOS	214
	x86: Boot Subsystems	215
	x86: Booting the Solaris Release	216
	x86: Screens Displayed During the Device Identification Phase	217
	x86: Menus Displayed During the Boot Phase	218
	x86: The Boot Process	220
16	Managing Removable Media Topics	223
17	Managing Removable Media (Overview)	225
	What's New in Managing Removable Media?	225
	Where to Find Managing Removable Media Tasks	226
	Removable Media Features and Benefits	226
	Comparison of Automatic and Manual Mounting	227
	What You Can Do With Volume Management	228
18	Accessing Removable Media (Tasks)	229
	Accessing Removable Media (Task Map)	229
	Accessing Removable Media (Overview)	230
	Using Removable Media Names	230
	Guidelines for Accessing Removable Media Data	232
	▼ How to Add a New Removable Media Drive	232
	Stopping and Starting Volume Management (vold)	233
	▼ How to Access Information on Removable Media	233
	▼ How to Copy Information From Removable Media	234
	▼ How to Play a Musical CD or DVD	235
	▼ How to Find Out If Removable Media Is Still in Use	236
	▼ How to Eject Removable Media	237
	Accessing Removable Media on a Remote System (Task Map)	238
	▼ How to Make Local Media Available to Other Systems	238

	▼ How to Access Removable Media on Remote Systems	241
19	Formatting Removable Media (Tasks)	245
	Formatting Removable Media (Task Map)	245
	Formatting Removable Media Overview	246
	Formatting Removable Media Guidelines	246
	Removable Media Hardware Considerations	247
	▼ How to Load a Removable Media	248
	▼ How to Format Removable Media (rmformat)	250
	▼ How to Format Removable Media for Adding a File System	250
	▼ How to Check a File System on Removable Media	252
	▼ How to Repair Bad Blocks on Removable Media	253
	Applying Read or Write and Password Protection to Removable Media	253
	▼ How to Enable or Disable Write Protection on Removable Media	253
	▼ How to Enable or Disable Read or Write Protection and a Password on Iomega Media	254
20	Writing CDs (Tasks)	257
	Working with Audio and Data CDs	257
	CD Media Commonly Used Terms	258
	Writing Data and Audio CDs	259
	Restricting User Access to Removable Media with RBAC	260
	▼ How to Restrict User Access to Removable Media with RBAC	260
	How to Identify a CD Writer	260
	▼ How to Check the CD Media	261
	Creating a Data CD	262
	▼ How to Create an ISO 9660 File System for a Data CD	262
	▼ How to Create a Multi-Session Data CD	263
	Creating an Audio CD	264
	▼ How to Create an Audio CD	265
	▼ How to Extract an Audio Track on a CD	266
	▼ How to Copy a CD	267
	▼ How to Erase CD-RW Media	267

21	Managing Software Topics	269
22	Managing Software (Overview)	271
	What's New in Software Management in the Solaris 9 Update Releases	271
	pkgadd and patchadd Support for Signed Packages and Patches	272
	prodreg Command Enhancements	272
	What's New in Software Management in the Solaris 9 Release?	272
	Signed Patches	272
	Solaris Product Registry 3.0	273
	Patch Analyzer	273
	Solaris Management Console Patch Manager	273
	Where to Find Software Management Tasks	274
	Overview of Software Packages	274
	Signed Packages and Patches	275
	Tools for Managing Software Packages	280
	Adding or Removing a Software Package (pkgadd)	281
	Key Points for Adding Software Packages (pkgadd)	281
	Guidelines for Removing Packages (pkgrm)	282
	Avoiding User Interaction When Adding Packages (pkgadd)	283
	Using an Administration File	283
	Using a Response File (pkgadd)	284
23	Managing Software (Tasks)	285
	Commands for Managing Software Packages	285
	Adding Software With the Solaris Web Start Program	286
	▼ How to Install Software With the Solaris Web Start Program	287
	Managing Software With the Solaris Product Registry GUI (Task Map)	288
	▼ How to View Installed or Uninstalled Software Information With the Product Registry GUI	290
	▼ How to Install Software With the Product Registry GUI	290
	▼ How to Uninstall Software With the Product Registry GUI	291
	Managing Software With the Solaris Product Registry Command-Line Interface (Task Map)	292
	▼ How to View Installed or Uninstalled Software Information (prodreg)	293
	▼ How to View Software Attributes (prodreg)	296
	▼ How to Check Dependencies Between Software Components (prodreg)	298
	▼ How to Identify Damaged Software Products (prodreg)	299

▼ How to Uninstall Software (prodreg)	302
▼ How to Uninstall Damaged Software (prodreg)	306
▼ How to Reinstall Damaged Software Components (prodreg)	309
Adding and Removing Signed Packages (Task Map)	311
▼ How to Import a Trusted Certificate into the Package Keystore (pkgadm addcert)	311
▼ How to Display Certificate Information (pkgadm listcert)	313
▼ How to Remove a Certificate (pkgadm removecert)	314
▼ How to Set Up a Proxy Server	314
▼ How to Add a Signed Package (pkgadd)	315
Managing Software Packages With Package Commands (Task Map)	316
▼ How to Add Software Packages (pkgadd)	317
Adding a Software Package to a Spool Directory	320
How to List Information About All Installed Packages (pkginfo)	321
▼ How to Check the Integrity of Installed Software Packages (pkgchk)	322
Removing Software Packages	324
▼ How to Remove Software Packages (pkgrm)	324
Adding and Removing Software Packages With Admintool (Task Map)	325
▼ How to Add Software Packages With Admintool	325
▼ How to Remove Software Packages With Admintool	327
24 Managing Solaris Patches (Overview)	329
What Is a Patch?	329
What Is a Signed Patch?	330
Accessing Solaris Patches	330
Solaris Patch Numbering	331
Tools for Managing Solaris Patches	332
Solaris Patch Management Tools	332
25 Managing Solaris Patches (Tasks)	337
Managing Patches in the Solaris Environment (Road Map)	337
Identifying Disk Space Requirements for Patches	338
Selecting Signed or Unsigned Patches for Your Environment	339
Adding Signed Patches With patchadd Command (Task Map)	339
How to Import a Trusted Certificate into Your Package Keystore (pkgadm addcert)	340
▼ How to Manually Download and Add a Signed Solaris Patch (patchadd)	341

▼ How to Automatically Download and Add a Signed Solaris Patch (patchadd)	342
Preparation for Managing Signed Patches with smpatch Command (Task Map)	343
Using the Solaris Patch Management Tools (smpatch)	344
How to Verify Package Requirements for Signed Patch Tools (smpatch)	345
▼ How to Download and Install the Solaris Patch Management Tools (smpatch)	346
▼ How to Import Sun Certificates Into the Java Keystore	347
▼ How to Change the Java Keystore Password	348
▼ How to Set Up Your Patch Environment (smpatch)	348
Managing Signed Patches With smpatch Command (Task Map)	350
▼ How to Download and Add a Signed Patch (smpatch)	350
▼ How to Remove a Signed Patch (smpatch)	353
Troubleshooting Problems With Signed Patches (smpatch)	354
Viewing Patch Tool Log Files	354
▼ How to Resolve a Sequestered Patch	355
▼ How to Remove Imported Certificates From Java Keystore	356
Managing Unsigned Solaris Patches (Task Map)	356
Displaying Information About Unsigned Solaris Patches	357
How to Display Information About Solaris Patches	357
Adding an Unsigned Solaris Patch	357
▼ How to Download an Unsigned Solaris Patch	358
▼ How to Add a Unsigned Solaris Patch	359
Removing an Unsigned Solaris Patch	359
▼ How to Remove an Unsigned Solaris Patch	360
26 Managing Devices Topics	361
27 Managing Devices (Tasks)	363
Where to Find Device Management Tasks	363
About Device Drivers	364
Automatic Configuration of Devices	364
Features and Benefits of Autoconfiguration	365
What You Need for Unsupported Devices	365
Displaying Device Configuration Information	366
driver not attached Message	366
Identifying a System's Devices	367

How to Display System Configuration Information	368
How to Display Device Information	369
Adding a Peripheral Device to a System	370
▼ How to Add a Peripheral Device	371
▼ How to Add a Device Driver	372
28 Dynamically Configuring Devices (Tasks)	373
Dynamic Reconfiguration and Hot-Plugging	373
Attachment Points	374
x86: Detaching PCI Adapter Cards	376
SCSI Hot-Plugging With the <code>cfgadm</code> Command (Task Map)	377
SCSI Hot-Plugging With the <code>cfgadm</code> Command	378
▼ How to Display Information About SCSI Devices	378
▼ How to Unconfigure a SCSI Controller	379
▼ How to Configure a SCSI Controller	379
▼ How to Configure a SCSI Device	380
▼ How to Disconnect a SCSI Controller	381
▼ SPARC: How to Connect a SCSI Controller	382
▼ SPARC: How to Add a SCSI Device to a SCSI Bus	382
▼ SPARC: How to Replace an Identical Device on a SCSI Controller	383
▼ SPARC: How to Remove a SCSI Device	384
SPARC: Troubleshooting SCSI Configuration Problems	385
▼ How to Resolve a Failed SCSI Unconfigure Operation	387
PCI Hot-Plugging With the <code>cfgadm</code> Command (Task Map)	387
x86: PCI Hot-Plugging With the <code>cfgadm</code> Command	388
▼ x86: How to Display PCI Slot Configuration Information	388
▼ x86: How to Remove a PCI Adapter Card	389
▼ x86: How to Add a PCI Adapter Card	389
x86: Troubleshooting PCI Configuration Problems	390
Reconfiguration Coordination Manager (RCM) Script Overview	391
What Is an RCM Script?	392
What Can an RCM Script Do?	392
How Does the RCM Script Process Work?	392
RCM Script Tasks	393
Application Developer RCM Script (Task Map)	393
System Administrator RCM Script (Task Map)	394
Naming an RCM Script	395

	Installing or Removing an RCM Script	395
	▼ How to Install an RCM Script	395
	▼ How to Remove an RCM Script	396
	▼ How to Test an RCM Script	396
	Tape Backup RCM Script Example	397
29	Using USB Devices (Overview/Tasks)	401
	Overview of USB Devices	401
	Commonly Used USB Acronyms	403
	USB Bus Description	403
	About USB in the Solaris Environment	406
	USB Keyboards and Mouse Devices	406
	USB Host Controller and Root Hub	407
	SPARC: USB Power Management	408
	Guidelines for USB Cables	408
	Using USB Mass Storage Devices (Task Map)	409
	Using USB Mass Storage Devices	409
	Using Non-Compliant USB Mass Storage Devices	410
	Hot-Plugging USB Devices	410
	▼ How to Add a USB Mass Storage Device With <code>vold</code> Running	411
	▼ How to Add a USB Mass Storage Device Without <code>vold</code> Running	411
	▼ How to Remove a USB Mass Storage Device With <code>vold</code> Running	412
	▼ How to Remove a USB Mass Storage Device Without <code>vold</code> Running	412
	Mounting USB Mass Storage Devices With or Without <code>vold</code> Running	413
	How to Mount or Unmount a USB Mass Storage Device With <code>vold</code> Running	414
	How to Mount or Unmount a USB Mass Storage Device Without <code>vold</code> Running	415
	▼ How to Add a USB Camera	415
	Using USB Audio Devices (Task Map)	417
	Using USB Audio Devices	417
	Hot-Plugging Multiple USB Audio Devices	418
	▼ How to Add USB Audio Devices	418
	▼ How to Identify Your System's Primary Audio Device	419
	▼ How to Change the Primary USB Audio Device	420
	▼ How to Remove Unused USB Audio Device Links	422
	Troubleshooting USB Audio Device Problems	422
	Solving USB Speaker Problems	423

	Hot-Plugging USB Devices With the <code>cfgadm</code> Command (Task Map)	423
	Hot-Plugging USB Devices With the <code>cfgadm</code> Command	424
	How to Display USB Device Information	425
	▼ How to Unconfigure a USB Device	426
	▼ How to Configure a USB Device	427
	▼ How to Logically Disconnect a USB Device	427
	▼ How to Logically Connect a USB Device	427
	▼ How to Logically Disconnect a USB Device Subtree	428
	▼ How to Reset a USB Device	428
30	Accessing Devices (Overview)	429
	Accessing Devices	429
	How Device Information Is Created	429
	How Devices Are Managed	430
	Device Naming Conventions	430
	Logical Disk Device Names	431
	Specifying the Disk Subdirectory	431
	Specifying the Slice	432
	x86: Disks With Direct Controllers	432
	SPARC: Disks With Bus-Oriented Controllers	433
	x86: Disks With SCSI Controllers	433
	Logical Tape Device Names	434
	Logical Removable Media Device Names	435
31	Managing Disks Topics	437
32	Managing Disks (Overview)	439
	What's New in Disk Management in the Solaris 9 8/03 Release?	439
	SPARC: Multiterabyte Volume Support With EFI Disk Label	440
	What's New in Disk Management in the Solaris 9 Release?	443
	Solaris Volume Manager and Soft Partitioning	444
	Where to Find Disk Management Tasks	444
	Overview of Disk Management	444
	Disk Terminology	445
	About Disk Slices	445
	SPARC: Disk Slices	446
	x86: Disk Slices	447

	Using Raw Data Slices	449
	Slice Arrangements on Multiple Disks	449
	Determining Which Slices to Use	450
	The <code>format</code> Utility	450
	When to Use the <code>format</code> Utility	451
	Guidelines for Using the <code>format</code> Utility	452
	Formatting a Disk	453
	About Disk Labels	454
	Partition Table	454
	Displaying Partition Table Information	455
	Dividing a Disk Into Slices	456
	Using the Free Hog Slice	457
33	Administering Disks (Tasks)	459
	Administering Disks (Task Map)	459
	Identifying Disks on a System	460
	▼ How to Identify the Disks on a System	460
	Formatting a Disk	462
	▼ How to Determine if a Disk is Formatted	463
	▼ How to Format a Disk	463
	Displaying Disk Slices	465
	▼ How to Display Disk Slice Information	465
	Creating and Examining a Disk Label	467
	▼ How to Label a Disk	467
	▼ How to Examine a Disk Label	469
	Recovering a Corrupted Disk Label	470
	▼ How to Recover a Corrupted Disk Label	471
	Adding a Third-Party Disk	473
	Creating a <code>format.dat</code> Entry	473
	▼ How to Create a <code>format.dat</code> Entry	474
	Automatically Configuring SCSI Disk Drives	474
	▼ How to Automatically Configure a SCSI Drive	475
	Repairing a Defective Sector	476
	▼ How to Identify a Defective Sector by Using Surface Analysis	477
	▼ How to Repair a Defective Sector	478
	Tips and Tricks for Managing Disks	479
	Debugging <code>format</code> Sessions	479

- 34 **SPARC: Adding a Disk (Tasks) 481**
 - SPARC: Adding a System Disk or a Secondary Disk (Task Map) 481
 - SPARC: Adding a System Disk or a Secondary Disk 482
 - ▼ SPARC: How to Connect a System Disk and Boot 483
 - ▼ SPARC: How to Connect a Secondary Disk and Boot 483
 - ▼ SPARC: How to Create Disk Slices and Label a Disk 484
 - ▼ SPARC: How to Create File Systems 489
 - ▼ SPARC: How to Install a Boot Block on a System Disk 490

- 35 **x86: Adding a Disk (Tasks) 491**
 - x86: Adding a System Disk or a Secondary Disk (Task Map) 491
 - x86: Adding a System or Secondary Disk 492
 - ▼ x86: How to Connect a System Disk and Boot 492
 - ▼ x86: How to Connect a Secondary Disk and Boot 493
 - x86: Guidelines for Creating an fdisk Partition 494
 - ▼ x86: How to Create a Solaris fdisk Partition 495
 - ▼ x86: How to Create Disk Slices and Label a Disk 501
 - ▼ x86: How to Create File Systems 502
 - ▼ x86: How to Install a Boot Block on a System Disk 503

- 36 **The format Utility (Reference) 505**
 - Recommendations and Requirements for Using The format Utility 505
 - Format Menu and Command Descriptions 506
 - The partition Menu 508
 - x86: The fdisk Menu 509
 - The analyze Menu 510
 - The defect Menu 511
 - The format.dat File 512
 - Contents of the format.dat File 513
 - Syntax of the format.dat File 513
 - Keywords in the format.dat File 513
 - Partition or Slice Tables (format.dat) 516
 - Specifying an Alternate Data File for the format utility 516
 - Rules for Input to format Commands 517
 - Specifying Numbers to format Commands 517

Specifying Block Numbers to <code>format</code> Commands	517
Specifying <code>format</code> Command Names	518
Specifying Disk Names to <code>format</code> Commands	519
Getting Help on the <code>format</code> Utility	519

37 Managing File Systems Topics 521

38 Managing File Systems (Overview) 523

What's New in File Systems in the Solaris 9 8/03 Release?	523
SPARC: Support of Multiterabyte UFS File Systems	523
What's New in File Systems in the Solaris 9 Release?	529
Extended File Attributes	530
UFS Snapshots	530
Improved UFS Direct I/O Concurrency	530
Improved <code>mkfs</code> Performance	531
New <code>labelit</code> Options for UDF File Systems	531
Where to Find File System Management Tasks	532
Overview of File Systems	532
Types of File Systems	533
Disk-Based File Systems	533
Network-Based File Systems	534
Virtual File Systems	534
Commands for File System Administration	537
How File System Commands Determine the File System Type	538
Manual Pages for Generic and Specific Commands	538
The Default Solaris File Systems	539
Swap Space	540
The UFS File System	540
UFS Logging	541
Planning UFS File Systems	542
UFS Direct Input/Output (I/O)	542
Mounting and Unmounting File Systems	543
The Mounted File System Table	545
The Virtual File System Table	546
The NFS Environment	547
Automounting or AutoFS	547
Determining a File System's Type	548

	How to Determine a File System's Type	548
39	Creating File Systems (Tasks)	551
	Creating a UFS File System	551
	Default Parameters for the <code>newfs</code> Command	552
	▼ How to Create a UFS File System	552
	Creating a Temporary File System (TMPFS)	554
	▼ How to Create a TMPFS File System	554
	Creating a Loopback File System (LOFS)	556
	▼ How to Create an LOFS File System	556
40	Mounting and Unmounting File Systems (Tasks)	559
	Overview of Mounting File Systems	559
	Commands for Mounting and Unmounting File Systems	560
	Commonly Used Mount Options	561
	Field Descriptions for the <code>/etc/vfstab</code> File	562
	Mounting File Systems	564
	How to Determine Which File Systems Are Mounted	564
	▼ How to Add an Entry to the <code>/etc/vfstab</code> File	564
	▼ How to Mount a File System (<code>/etc/vfstab</code> File)	566
	▼ How to Mount a UFS File System (<code>mount</code> Command)	567
	▼ How to Mount a UFS File System Without Large Files (<code>mount</code> Command)	568
	▼ How to Mount an NFS File System (<code>mount</code> Command)	569
	▼ x86: How to Mount a PCFS (DOS) File System From a Hard Disk (<code>mount</code> Command)	570
	Unmounting File Systems	571
	Prerequisites for Unmounting File Systems	571
	How to Verify a File System is Unmounted	572
	▼ How to Stop All Processes Accessing a File System	572
	▼ How to Unmount a File System	573
41	Using The CacheFS File System (Tasks)	575
	High-Level View of Using the CacheFS File System (Task Map)	575
	Overview of the CacheFS File System	576
	How a CacheFS File System Works	576
	CacheFS File System Structure and Behavior	577

Creating and Mounting a CacheFS File System (Task Map)	578
▼ How to Create the Cache	579
Mounting a File System in the Cache	579
▼ How to Mount a CacheFS File System (mount)	580
▼ How to Mount a CacheFS File System (/etc/vfstab)	582
▼ How to Mount a CacheFS File System (AutoFS)	583
Maintaining a CacheFS File System (Task Map)	583
Maintaining a CacheFS File System	584
Modifying a CacheFS File System	584
▼ How to Display Information About a CacheFS File System	585
Consistency Checking of a CacheFS File System	586
▼ How to Specify Cache Consistency Checking on Demand	586
▼ How to Delete a CacheFS File System	586
▼ How to Check the Integrity of a CacheFS File System	588
Packing a Cached File System (Task Map)	589
Packing a CacheFS File System	589
How to Pack Files in the Cache	590
How to Display Packed Files Information	591
Using Packing Lists	592
How to Create a Packing List	592
How to Pack Files in the Cache With a Packing List	593
Unpacking Files or Packing Lists From the Cache	593
How to Unpack Files or Packing Lists From the Cache	593
Troubleshooting <code>cachefspack</code> Errors	594
Collecting CacheFS Statistics (Task Map)	598
Collecting CacheFS Statistics	598
How to Set Up CacheFS Logging	600
How to Locate the CacheFS Log File	600
How to Stop CacheFS Logging	601
How to View the Working Set (Cache) Size	601
Viewing CacheFS Statistics	602
How to View CacheFS Statistics	602
42 Configuring Additional Swap Space (Tasks)	605
About Swap Space	605
Swap Space and Virtual Memory	606
Swap Space and the TMPFS File System	606

	Swap Space as a Dump Device	607
	How Do I Know If I Need More Swap Space?	607
	Swap-Related Error Messages	608
	TMPFS-Related Error Messages	608
	How Swap Space Is Allocated	608
	The <code>/etc/vfstab</code> File	609
	Planning for Swap Space	609
	Monitoring Swap Resources	610
	Adding More Swap Space	611
	Creating a Swap File	611
	▼ How to Create a Swap File and Make It Available	612
	Removing a Swap File From Use	613
	▼ How to Remove Unneeded Swap Space	613
43	Checking UFS File System Consistency (Tasks)	615
	File System Consistency	615
	How the File System State Is Recorded	616
	What the <code>fsck</code> Command Checks and Tries to Repair	618
	Why Inconsistencies Might Occur	618
	The UFS Components That Are Checked for Consistency	618
	The <code>fsck</code> Summary Message	624
	Interactively Checking and Repairing a UFS File System	624
	▼ How to See If a File System Needs Checking	625
	▼ How to Check File Systems Interactively	625
	Preening UFS File Systems	626
	▼ How to Preen a UFS File System	627
	Fixing a UFS File System That the <code>fsck</code> Command Cannot Repair	627
	Restoring a Bad Superblock	628
	▼ How to Restore a Bad Superblock	628
	Syntax and Options for the <code>fsck</code> Command	630
44	UFS File System (Reference)	631
	Default Directories for root (<code>/</code>) and <code>/usr</code> File Systems	631
	The Platform-Dependent Directories	639
	The Structure of Cylinder Groups for UFS File Systems	639
	The Boot Block	640
	The Superblock	640

	Inodes	640
	Data Blocks	642
	Free Blocks	642
	Custom File System Parameters	643
	Logical Block Size	643
	Fragment Size	644
	Minimum Free Space	644
	Rotational Delay	645
	Optimization Type	645
	Number of Inodes (Files)	645
	Maximum UFS File and File System Size	646
	Maximum Number of UFS Subdirectories	646
	Commands for Creating a Customized File System	646
	The <code>newfs</code> Command Syntax, Options, and Arguments	646
	The Generic <code>mkfs</code> Command	649
45	Backing Up and Restoring Files and File Systems Topics	651
46	Backing Up and Restoring File Systems (Overview)	653
	What's New in Backing Up and Restoring File Systems?	653
	UFS Snapshots	653
	Where to Find Backup and Restore Tasks	654
	Definition: Backing Up and Restoring File Systems	654
	Why You Should Back Up File Systems	655
	Planning Which File Systems to Back Up	655
	Choosing the Type of Backup	657
	Choosing a Tape Device	658
	High-Level View of Backing Up and Restoring File Systems (Task Map)	659
	Guidelines for Scheduling Backups	660
	How Often Should You Do Backups?	660
	Using Dump Levels to Create Incremental Backups	660
	Sample Backup Schedules	662
	Example—Daily Cumulative, Weekly Cumulative Backups	662
	Example—Daily Cumulative, Weekly Incremental Backups	663
	Example—Daily Incremental, Weekly Cumulative Backups	664
	Example—Monthly Backup Schedule for a Server	665
	Suggestions for Scheduling Backups	668

47	Backing Up Files and File Systems (Tasks)	671
	Backing Up Files and File System (Task Map)	671
	Preparing for File System Backups	672
	▼ How to Find File System Names	672
	▼ How to Determine the Number of Tapes Needed for a Full Backup	673
	Backing Up a File System	673
	▼ How to Backup a File System to Tape	674
48	Using UFS Snapshots (Tasks)	681
	Using UFS Snapshots (Task Map)	681
	UFS Snapshots Overview	682
	Why Use UFS Snapshots?	682
	UFS Snapshots Performance Issues	683
	Creating and Deleting UFS Snapshots	683
	▼ How to Create a UFS Snapshot	684
	▼ How to Display UFS Snapshot Information	684
	Deleting a UFS Snapshot	685
	▼ How to Delete a UFS Snapshot	685
	Backing Up a UFS Snapshot	686
	▼ How to Create a Full Backup of a UFS Snapshot (<code>ufsdump</code>)	686
	▼ How to Create an Incremental Backup of a UFS Snapshot (<code>ufsdump</code>)	687
	▼ How to Back Up a UFS Snapshot (<code>tar</code>)	688
	Restoring Data From a UFS Snapshot Backup	688
49	Restoring Files and File Systems (Tasks)	689
	Restoring Files and File System Backups (Task Map)	689
	Preparing to Restore Files and File Systems	690
	Determining the File System Name	690
	Determining the Type of Tape Device You Need	691
	Determining the Tape Device Name	691
	Restoring Files and File Systems	691
	▼ How to Determine Which Tapes to Use	692
	▼ How to Restore Files Interactively	693
	▼ How to Restore Specific Files Non-Interactively	695
	▼ How to Restore a Complete File System	697
	▼ How to Restore the root (/) and /usr File Systems	700

50	UFS Backup and Restore Commands (Reference)	703
	How the <code>ufsdump</code> Command Works	703
	Determining Device Characteristics	703
	Detecting the End of Media	704
	Copying Data With <code>ufsdump</code>	704
	Role of the <code>/etc/dumpdates</code> File	704
	Backup Device (<i>dump-file</i>) Argument	705
	Specifying Files to Back Up	707
	Specifying Tape Characteristics	707
	Limitations of the <code>ufsdump</code> Command	707
	Options and Arguments for the <code>ufsdump</code> Command	708
	Default <code>ufsdump</code> Options	708
	Options for the <code>ufsdump</code> Command	708
	The <code>ufsdump</code> Command and Security Issues	710
	Options and Arguments for the <code>ufsrestore</code> Command	711
51	Copying UFS Files and File Systems (Tasks)	715
	Commands for Copying File Systems	715
	Copying File Systems Between Disks	717
	Making a Literal File System Copy	717
	▼ How to Copy a Disk (<code>dd</code>)	718
	Copying Directories Between File Systems (<code>cpio</code> Command)	720
	▼ How to Copy Directories Between File Systems (<code>cpio</code>)	720
	Copying Files and File Systems to Tape	721
	Copying Files to Tape (<code>tar</code> Command)	723
	▼ How to Copy Files to a Tape (<code>tar</code>)	723
	▼ How to List the Files on a Tape (<code>tar</code>)	724
	▼ How to Retrieve Files From a Tape (<code>tar</code>)	724
	Copying Files to a Tape With the <code>pax</code> Command	726
	▼ How to Copy Files to a Tape (<code>pax</code>)	726
	Copying Files to Tape With the <code>cpio</code> Command	727
	▼ How to Copy All Files in a Directory to a Tape (<code>cpio</code>)	727
	▼ How to List the Files on a Tape (<code>cpio</code>)	728
	▼ How to Retrieve All Files From a Tape (<code>cpio</code>)	729
	▼ How to Retrieve Specific Files From a Tape (<code>cpio</code>)	730
	Copying Files to a Remote Tape Device	731
	▼ How to Copy Files to a Remote Tape Device (<code>tar</code> and <code>dd</code>)	731

▼ How to Extract Files From a Remote Tape Device	732
Copying Files and File Systems to Diskette	733
Things You Should Know When Copying Files to Diskettes	733
▼ How to Copy Files to a Single Formatted Diskette (<code>tar</code>)	734
▼ How to List the Files on a Diskette (<code>tar</code>)	735
▼ How to Retrieve Files From a Diskette (<code>tar</code>)	735
How to Archive Files to Multiple Diskettes	736
Copying Files With a Different Header Format	736
How to Create an Archive for Older SunOS Releases	737
Retrieving Files Created With the <code>bar</code> Command	737
▼ How to Retrieve <code>bar</code> Files From a Diskette	737
52 Managing Tape Drives (Tasks)	739
Choosing Which Media to Use	739
Backup Device Names	740
Specifying the Rewind Option for a Tape Drive	741
Specifying Different Densities for a Tape Drive	742
Displaying Tape Drive Status	742
▼ How to Display Tape Drive Status	742
Handling Magnetic Tape Cartridges	743
How to Retension a Magnetic Tape Cartridge	743
How to Rewind a Magnetic Tape Cartridge	744
Guidelines for Drive Maintenance and Media Handling	744
Index	745

Preface

System Administration Guide: Basic Administration is part of a set that includes a significant part of the Solaris™ system administration information. This guide contains information for both SPARC® based and x86 based systems.

This book assumes you have completed the following tasks:

- Installed the SunOS 5.9 operating system
- Set up all the networking software that you plan to use

The SunOS 5.9 operating system is part of the Solaris product family, which also includes many features, including the Solaris Common Desktop Environment (CDE). The SunOS 5.9 operating system is compliant with AT&T's System V, Release 4 operating system.

For the Solaris 9 release, new features interesting to system administrators are covered in sections called *What's New in ... ?* in the appropriate chapters.

Note – The Solaris operating environment runs on two types of hardware, or platforms, SPARC and x86. The Solaris operating environment runs on both 64-bit and 32-bit address spaces. The information in this document pertains to both platforms and address spaces unless called out in a special chapter, section, note, bullet, figure, table, example, or code example.

Who Should Use This Book

This book is intended for anyone responsible for administering one or more systems running the Solaris 9 release. To use this book, you should have 1-2 years of UNIX® system administration experience. Attending UNIX system administration training courses might be helpful.

How the System Administration Volumes Are Organized

Here is a list of the topics that are covered by the volumes of the System Administration Guides.

Book Title	Topics
<i>System Administration Guide: Basic Administration</i>	User accounts and groups, server and client support, shutting down and booting a system, removable media, managing software (packages and patches), disks and devices, file systems, and backing up and restoring data
<i>System Administration Guide: Advanced Administration</i>	Printing services, terminals and modems, system resources (disk quotas, accounting, and crontabs), system processes, and troubleshooting Solaris software problems
<i>System Administration Guide: IP Services</i>	TCP/IP networks, IPv4 and IPv6, DHCP, IP Security, Mobile IP, and IP Network Multipathing
<i>System Administration Guide: Naming and Directory Services (DNS, NIS, and LDAP)</i>	DNS, NIS, and LDAP naming and directory services
<i>System Administration Guide: Naming and Directory Services (FNS and NIS+)</i>	FNS and NIS+ naming and directory services
<i>System Administration Guide: Resource Management and Network Services</i>	Resource management, remote file systems, mail, SLP, and PPP
<i>System Administration Guide: Security Services</i>	Auditing, PAM, RBAC, and SEAM

To view license terms, attribution, and copyright statements for open source software included in this release of the Solaris operating environment, the default path is `/usr/share/src/freeware-name` or `/usr/sfw/share/src/freeware-name`. If the Solaris operating environment has been installed anywhere other than the default location, modify the given path to access the file at the installed location.

Accessing Sun Documentation Online

The docs.sun.comSM Web site enables you to access Sun technical documentation online. You can browse the docs.sun.com archive or search for a specific book title or subject. The URL is `http://docs.sun.com`.

What Typographic Conventions Mean

The following table describes the typographic conventions used in this book.

TABLE P-1 Typographic Conventions

Typeface or Symbol	Meaning	Example
AaBbCc123	The names of commands, files, and directories; on-screen computer output	Edit your <code>.login</code> file. Use <code>ls -a</code> to list all files. <code>machine_name%</code> you have mail.
AaBbCc123	What you type, contrasted with on-screen computer output	<code>machine_name%</code> su Password:
<i>AaBbCc123</i>	Command-line placeholder: replace with a real name or value	To delete a file, type rm <i>filename</i> .
<i>AaBbCc123</i>	Book titles, new words or terms, or words to be emphasized.	Read Chapter 6 in <i>User's Guide</i> . These are called <i>class</i> options. Do <i>not</i> save changes yet.

Shell Prompts in Command Examples

The following table shows the default system prompt and superuser prompt for the C shell, Bourne shell, and Korn shell.

TABLE P-2 Shell Prompts

Shell	Prompt
C shell prompt	<code>machine_name%</code>
C shell superuser prompt	<code>machine_name#</code>
Bourne shell and Korn shell prompt	<code>\$</code>
Bourne shell and Korn shell superuser prompt	<code>#</code>

General Conventions

Be aware of the following conventions used in this book.

- When following steps or using examples, be sure to type double-quotes (`"`), left single-quotes (`'`), and right single-quotes (`'`) exactly as shown.
- The key referred to as Return is labeled Enter on some keyboards.
- The root path usually includes the `/sbin`, `/usr/sbin`, `/usr/bin`, and `/etc` directories, so the steps in this book show the commands in these directories without absolute path names. Steps that use commands in other, less common, directories show the absolute paths in the examples.
- The examples in this book are for a basic SunOS software installation without the Binary Compatibility Package installed and without `/usr/ucb` in the path.



Caution – If `/usr/ucb` is included in a search path, it should always be at the end of the search path. Commands like `ps` or `df` are duplicated in `/usr/ucb` with different formats and options from the SunOS commands.

Solaris Management Tools (Roadmap)

This chapter provides a roadmap to Solaris management tools.

- “What’s New in Solaris Management Tools?” on page 31
- “Matrix of Solaris Management Tools Support” on page 32
- “Feature Descriptions for Solaris 9 Management Tools” on page 33
- “Feature Descriptions for Solaris 8 Management Tools” on page 34
- “Feature Descriptions for Previous Solaris Management Tools” on page 36
- “Availability Solaris Management Commands” on page 36
- “For More Information About Solaris Management Tools” on page 39

What’s New in Solaris Management Tools?

These tools are new or changed in the Solaris 9 release:

- Diskless client support
- Solaris DHCP
- Resource Management
- Solaris Management Console (referred to as the console) tools suite
- Solaris Volume Manager (previously Solstice™ DiskSuite)
- Solaris Patch Manager
- Product Registry

The following table provides a brief description of each tool and where to find more information about them.

TABLE 1-1 New or Changed Solaris Management Tools in the Solaris 9 Release

Solaris Administration Tool	Description	For More Information
Diskless Client Support	Provides a command-line interface for managing diskless client systems.	Chapter 8
Resource Management	Enables you to control how applications use available system resources.	<i>System Administration Guide: Resource Management and Network Services</i>
Solaris DHCP	Provides improved performance, capacity, and flexibility in managing DHCP in your network.	“About Solaris DHCP (Overview)” in <i>System Administration Guide: IP Services</i>
Solaris Management Console ¹	Serves as a launching point for a variety of GUI-based system management tools.	This guide and the console online help
Solaris Volume Manager (previously Solstice™ DiskSuite)	Provides robust storage management and is launched from the Solaris Management Console. The command-line interface is also available.	<i>Solaris Volume Manager Administration Guide</i>
Solaris Patch Manager	You can use this tool to add signed and unsigned patches to your system.	Chapter 24
Solaris Product Registry	The <code>prodreg</code> command includes <code>browse</code> , <code>info</code> , <code>unregister</code> , and <code>uninstall</code> subcommands that are similar to the Solaris Product Registry graphical user interface.	“Managing Software With the Solaris Product Registry Command-Line Interface (Task Map)” on page 292

¹ Do not confuse this tool with Sun Management Center (SunMC). For information about the Sun Management Center product, see <http://www.sun.com/solaris/sunmanagementcenter/docs>.

Matrix of Solaris Management Tools Support

This section provides information about tools that are primarily used to manage users, groups, clients, disks, printers, and serial ports.

This table lists the various Solaris management GUI tools and whether they are currently supported.

TABLE 1–2 Matrix of Solaris Management Tool Support

	Solaris 2.6 and Earlier Releases	Solaris 7	Solaris 8	Solaris 9
admintool	Supported	Supported	Supported	Supported
Solstice AdminSuite 2.3	Supported	Supported	Not Supported	Not Supported
Solstice AdminSuite 3.0	Supported (Solaris 2.6 release only)	Supported	Supported	Not Supported
Solaris Management Tools 1.0	Supported	Supported	Supported	Not Supported
Solaris Management Tools 2.0	Not Supported	Not Supported	Supported (Solaris 8 01/01, 4/01, 7/01, 10/01, 2/02 releases only)	Not Supported
Solaris Management Tools 2.1	Not Supported	Not Supported	Not Supported	Supported

If you want to perform administration tasks on a system with a text-based terminal as the console, use Solaris Management Console commands instead. For more information, see Table 1–6.

Feature Descriptions for Solaris 9 Management Tools

This table describes the tools available in the Solaris 9 releases.

TABLE 1–3 Feature Descriptions for Solaris 9 Management Tools

Feature or Tool	Supported in admintool?	Supported in Solaris Management Console 2.1
AutoClient Support	No	No

TABLE 1-3 Feature Descriptions for Solaris 9 Management Tools *(Continued)*

Feature or Tool	Supported in admintool?	Supported in Solaris Management Console 2.1
Computers and Networks Tool	No	Yes
Diskless Client Support	No	Yes, a diskless client CLI is available
Disks Tool	No	Yes
Enhanced Disk Tool (Solaris Volume Manager)	No	Yes
Job Scheduler	No	Yes
Log Viewer	No	Yes
Mail Alias Support	No	Yes
Mounts and Shares Tool	No	Yes
Name Service Support	No	For users, groups, and network information only
Patch Tool	No	Yes
Performance Tool	No	Yes
Printer Support	Yes	Solaris Print Manager is available separately
Projects Tool	No	Yes
RBAC Support	No	Yes
RBAC Tool	No	Yes
Serial Port Tool	Yes	Yes
Software Package Tool	Yes	No
System Information Tool	No	Yes
User/Group Tool	Yes	Yes

Feature Descriptions for Solaris 8 Management Tools

This table lists the tools that are available in the Solaris 8 release and various Solaris 8 update releases.

TABLE 1-4 Feature Descriptions for Solaris 8 Management Tools

Feature or Tool	Supported in admintool?	Supported in Solstice AdminSuite 3.0? (Solaris 8 and Solaris 8 6/00 and 10/00 only)	Supported in Solaris Management Console 1.0?	Supported in Solaris Management Console 2.0? (Solaris 8 1/01, 4/01, 7/01, 10/01, 2/02 only)
AutoClient/Diskless Client Support	No	No (but an AutoClient CLI is available separately)	No	No (but a diskless CLI and AutoClient CLI is available separately)
Disks Tool	No	No	No	Yes
Job Scheduler	No	No	No	Yes
Log Viewer	No	Yes	No	Yes
Mail Alias Support	No	Yes	No	Yes
Mounts and Shares Tool	No	Yes	No	Yes
Name Service Support	No	Yes	No	For users, groups, and network information only
Printer Support	Yes	Solaris Print Manager is available	Yes	No, but Solaris Print Manager is available
Software Package Tool	Yes	No	Yes	No
RBAC Support	No	Yes (rights support only)	No	Yes
RBAC Tool	No	RBAC CLI is available separately	No	Yes
Serial Port Tool	Yes	Yes	Yes	Yes
User/Group Tool	Yes	Yes	Yes	Yes

Feature Descriptions for Previous Solaris Management Tools

This table describes the tools that are available in releases prior to the Solaris 8 release.

TABLE 1-5 Feature Descriptions for Previous Solaris Management Tools

Feature or Tool	Supported in admintool?	Supported in Solstice AdminSuite 2.3?	Supported in Solstice AdminSuite 3.0? (Solaris 2.6 only)
AutoClient/Diskless Client Support	No	Yes	No (but an AutoClient CLI is available separately)
Disks Tool	No	Yes	No
Log Viewer	No	No	Yes
Mail Alias Support	No	Yes	Yes
Mounts and Shares Tool	No	Yes	Yes
Name Service Support	No	Yes	Yes
Printer Support	Yes	Yes	Solaris Print Manager is available
RBAC Support	No	No	Yes (rights support only)
RBAC Tool	No	No	RBAC CLI is available separately
Serial Port Tool	Yes	Yes	Yes
User/Group Tool	Yes	Yes	Yes

Availability Solaris Management Commands

This series of tables lists commands that perform the same tasks as the Solaris management tools. For information on diskless client support, see Chapter 8.

Solaris 9 System Management Commands

This table describes the commands that provide the same functionality as the Solaris management tools. You must be superuser or assume an equivalent role to use these commands. Some of these commands are for the local system only. Others commands operate in a name service environment. See the appropriate man page and refer to the -D option.

TABLE 1-6 Descriptions for Solaris Management Commands

Command	Description	Man Page
smc	Starts the Solaris Management Console	smc(1M)
smcron	Manages crontab jobs	smcron(1M)
smdiskless	Manages diskless client support	smdiskless(1M)
smexec	Manages entries in the exec_attr database	smexec(1M)
smgroup	Manages group entries	smgroup(1M)
smlog	Manages and views WBEM log files	smlog(1M)
smmultiuser	Manages bulk operations on multiple user accounts	smmultiuser(1M)
smosservice	Adds OS services and diskless client support	smosservice(1M)
smprofile	Manages profiles in the prof_attr and exec_attr databases	smprofile(1M)
smrole	Manages roles and users in role accounts	smrole(1M)
smserialport	Manages serial ports	smserialport(1M)
smuser	Manages user entries	smuser(1M)

This table describes the commands you can use to manage RBAC from the command line. You must be superuser or assume an equivalent role to use these commands. These commands cannot be used to manage RBAC information in a name service environment.

TABLE 1-7 RBAC Command Descriptions

Command	Description	References
auths	Displays authorizations granted to a user	auths(1)
profiles	Displays execution profiles for a user	profiles(1)
roleadd	Adds a new role to the system	roleadd(1M)
roles	Displays roles granted to a user	roles(1)

This table describes the commands you can use to manage users, groups, and RBAC features from the command line. You must be superuser or assume an equivalent role to use these commands. These commands cannot be used to manage user and group information in a name service environment.

TABLE 1-8 Solaris User/Group Command Descriptions

Command	Description	References
useradd, usermod, userdel	Adds, modifies, or removes a user.	useradd(1M), usermod(1M), userdel(1M)
groupadd, groupmod, groupdel	Adds, modifies, or removes a group.	groupadd(1M), groupmod(1M), groupdel(1M)

Solaris 8 System Management Commands

All of the commands listed Table 1-7 and Table 1-8 are available in the Solaris 8 release.

Descriptions for Previous Solaris Management Commands

This table describes the commands that provide equivalent functionality to the Solstice AdminSuite™ 2.3 and Solstice AutoClient™ 2.3 GUI tools. You must be superuser or be a member of the sysadmin group to use these commands.

Note – The Solstice AdminSuite 2.3 and Solstice AutoClient 2.3 command man pages are not available online. You must have access to the Solstice AdminSuite 2.3 and Solstice AutoClient 2.3 software to view these man pages.

All of the commands listed in Table 1–8 are also available in previous Solaris releases.

TABLE 1–9 Descriptions for Solstice AdminSuite™ 2.3/Solstice AutoClient™ 2.1 Commands

Command	Description	For More Information
admhostadd, admhostmod, admhostdel, admhostls	Adds, modifies, removes, and lists support for client and server systems set up with the AdminSuite software	<i>Solstice AdminSuite 2.3 Administration Guide</i> and <i>Solstice AutoClient 2.1 Administration Guide</i>
admuseradd, admusermod, admuserdel, admuserls, admgroupadd, admgroupmod, admgroupdel, admgrouppls	Adds, modifies, removes, and lists users and groups	<i>Solstice AdminSuite 2.3 Administration Guide</i>

For More Information About Solaris Management Tools

This table identifies where to find more information about Solaris management tools.

TABLE 1–10 For More Information About Solaris Management Tools

Tool	Availability	For More Information
Solaris Management Console 2.1 suite of tools	Solaris 9 releases	This guide and the console online help
Solaris Management Console 2.0 suite of tools	Solaris 8 1/01, 4/01, 7/01, 10/01, and 2/02 releases	The Solaris Management Console online help
Solaris Management Console 1.0 suite of tools	Solaris 2.6, Solaris 7, and Solaris 8 releases	<i>Solaris Easy Access Server 3.0 Installation Guide</i>
admintool	Solaris 9, Solaris 8, and previous Solaris releases	admintool(1M)

TABLE 1–10 For More Information About Solaris Management Tools (Continued)

Tool	Availability	For More Information
AdminSuite 2.3	Solaris 2.4, Solaris 2.5, Solaris 2.5.1, Solaris 2.6, and Solaris 7 releases	<i>Solstice AdminSuite 2.3 Administration Guide</i>
AdminSuite 3.0	Solaris 8, Solaris 8 6/00, and Solaris 8 10/00 releases	<i>Solaris Easy Access Server 3.0 Installation Guide</i>
AutoClient 3.0.1	Solaris 8 releases	Call your local service provider
	Solaris 9 releases – Consider using the Web Start Flash installation feature	<i>Solaris 9 12/03 Installation Guide</i>
Diskless Client CLI	Solaris 8 1/01, 4/01, 7/01, 10/01, 2/02, and Solaris 9 releases	Chapter 8

Working With the Solaris™ Management Console (Tasks)

This chapter provides an overview of the Solaris management tools used to perform system administration tasks. Topics include starting the Solaris Management Console (console), setting up Role-Based Access Control (RBAC) to use with the console, and working with the Solaris management tools in a name service environment.

For information on the procedures associated with performing system management tasks with the Solaris Management Console, see:

- “Using the Solaris Management Tools With RBAC (Task Map)” on page 50
- “Using the Solaris Management Tools in a Name Service Environment (Task Map)” on page 56

For information on troubleshooting Solaris Management Console problems, see “Troubleshooting the Solaris Management Console” on page 63.

Solaris Management Console (Overview)

The following sections provide information about the Solaris Management Console.

What Is the Solaris Management Console?

The Solaris Management Console is a container for GUI-based management tools that are stored in collections referred to as *toolboxes*. The console includes a default toolbox with many basic management tools, including tools for managing users, projects, and cron jobs; for mounting and sharing file systems; and for managing disks and serial ports. For a brief description of each Solaris management tool, see Table 2-1.

You can always add tools to the existing toolbox, or you can create new toolboxes.

The Solaris Management Console has three primary components:

- The Solaris Management Console Client
Called *console*, this is the visible interface and contains the GUI tools used to perform management tasks.
- The Solaris Management Console Server
This component is located either on the same machine as the console or remotely, and provides all the *back end* functionality that allows management through the console.
- The Solaris Management Console Toolbox Editor
This application, which looks similar to the console, is used to add or modify toolboxes, to add tools to a toolbox, or to extend the scope of a toolbox. For example, you would add a toolbox to manage a name service domain.

The default toolbox is visible when you start the console.

Solaris Management Console Tools

This table describes the tools included in the default Solaris Management Console toolbox and provides cross-references to background information for each tool.

TABLE 2-1 Solaris Management Console Tool Suite

Category	Tool	Description	For More Information
System Status	System Information	Monitors and manages system information such as date, time, and timezone.	“Displaying and Changing System Information (Tasks)” in <i>System Administration Guide: Advanced Administration</i>
	Log Viewer	Monitors and manages the Solaris Management Console tools log and system logs.	“Troubleshooting Software Problems (Overview)” in <i>System Administration Guide: Advanced Administration</i>
	Processes	Monitors and manages system processes.	“Processes and System Performance” in <i>System Administration Guide: Advanced Administration</i>

TABLE 2-1 Solaris Management Console Tool Suite (Continued)

Category	Tool	Description	For More Information
System Configuration	Performance	Monitors system performance.	“Managing System Performance (Overview)” in <i>System Administration Guide: Advanced Administration</i>
	Users	Manages users, rights, roles, groups, and mailing lists.	“What Are User Accounts and Groups?” on page 69 and “Role-Based Access Control (Overview)” in <i>System Administration Guide: Security Services</i>
	Projects	Creates and manages entries in the <code>/etc/project</code> database.	“Projects and Tasks” in <i>System Administration Guide: Resource Management and Network Services</i>
Services	Computers and Networks	Creates and monitors computer and network information.	Solaris Management Console online help
	Patches	Manages patches.	Chapter 24
	Scheduled Jobs	Creates and manages scheduled <code>cron</code> jobs.	“Ways to Automatically Execute System Tasks” in <i>System Administration Guide: Advanced Administration</i>
Storage	Mounts and Shares	Mounts and shares file systems.	Chapter 38
	Disks	Creates and manages disk partitions.	Chapter 32
	Enhanced Storage	Creates and manages volumes, hot spare pools, state database replicas, and disk sets.	<i>Solaris Volume Manager Administration Guide</i>
Devices and Hardware	Serial Ports	Sets up terminals and modems.	“Managing Terminals and Modems (Overview)” in <i>System Administration Guide: Advanced Administration</i>

Context-sensitive help is available after you start a tool. For broader, more in-depth online information than the context help provides, see the expanded help topics, which you can reach from the console Help menu.

Why Use the Solaris Management Console?

The console provides a set of tools with many benefits for administrators. The console does the following:

- Supports all experience levels
Inexperienced administrators can complete tasks by using the graphical interface, which includes dialog boxes, wizards, and context help. Experienced administrators will find that the console provides a convenient, secure alternative to using `vi` to manage hundreds of configuration parameters spread across tens or hundreds of systems.
- Controls user access to the system
Although any user can access the console by default, only superuser can make changes in the initial configuration. As described in “Role-Based Access Control (Overview)” in *System Administration Guide: Security Services*, it is possible to create special user accounts called *roles* that can be assigned to users, typically administrators, who are permitted to make specific system changes.
The key benefit of RBAC is that roles can be limited to only those tasks that are necessary for doing their jobs. RBAC is *not* required for using the Solaris management tools. You can run all tools as superuser without making any changes.
- Provides a command line interface
If preferred, administrators can operate the Solaris management tools through a command-line interface (CLI). Some commands are written specifically to mimic the GUI tool functions, such as the commands for managing users. These new commands are listed in Table 1–6, with the names and brief descriptions of each command. There is also a man page for each command.
For those Solaris management tools that have no special commands, such as the Mounts and Shares tools, use the standard UNIX commands.

For in-depth information about how RBAC works, its benefits, and how to apply those benefits to your site, see “Role-Based Access Control (Overview)” in *System Administration Guide: Security Services*.

To learn more about using RBAC with the Solaris management tools, see “Using the Solaris Management Tools With RBAC (Task Map)” on page 50.

Organization of the Solaris Management Console

In the following figure, the console is shown with the Users Tool open.

The main part of the console consists of three panes:

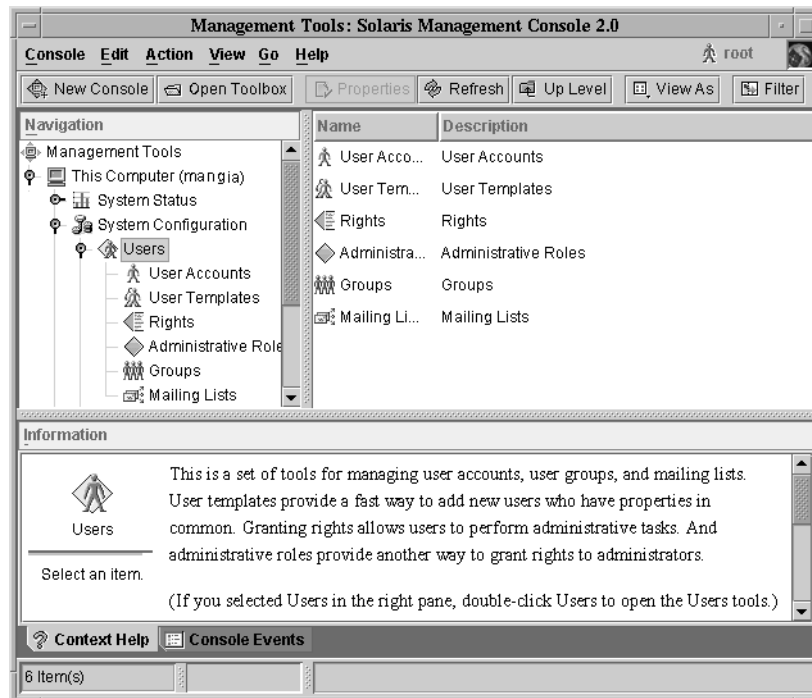

FIGURE 2-1 Solaris Management Console – Users Tool

- Navigation pane (at the left) – For accessing tools (or sets of tools), folders, or other toolboxes. Icons in the navigation pane are called nodes and are expandable if they are folders or toolboxes.
- View pane (at the right) – For viewing information related to the node selected in the navigation pane, shows either the contents of the selected folder, subordinate tools, or data associated with the selected tool.
- Information pane (at the bottom) – For displaying context-sensitive help or console events.

Changing the Solaris Management Console Window

The layout of the console window is highly configurable. You can use the following features to change the console window layout:

- View menu – Use the Show option in the View menu to hide or display the optional bars and panes. The other options in the View menu control the display of nodes in the view pane.
- Console menu – Use the Preferences option to set the following: the initial toolbox, the orientation of panes, clicking or double-clicking for selection, text or icons in the tool bar, fonts, default tool loading, authentication prompts, and advanced logins.
- Context Help or Console Events toggles – Use the icons at the bottom of the information pane to toggle between the display of context-sensitive help and console events.

Solaris Management Console Documentation

The main source of documentation for using the console and its tools is the online help system. Two forms of online help are available: context-sensitive help and expanded help topics.

- Context-sensitive help responds to your use of the console tools.
Clicking the cursor on tabs, entry fields, radio buttons, and so forth, causes the appropriate help to appear in the Information pane. You can close, or reopen the Information pane by clicking the question mark button on dialog boxes and wizards.
- Expanded help topics are available from the Help menu or by clicking cross reference links in some context-sensitive help.
These topics appear in a separate viewer and contain more in-depth information than is provided by the context help. Topics include overviews of each tool, explanations of how each tool works, files used by a specific tool, and troubleshooting.

For a brief overview of each tool, refer to Table 2–1.

How Much Role-Based Access Control?

As described in “Why Use the Solaris Management Console?” on page 44, a major advantage of using the Solaris management tools is the ability to use Role-Based Access Control (RBAC). RBAC provides administrators with access to just the tools and commands they need to perform their jobs.

Depending on your security needs, you can use varying degrees of RBAC, as follows:

RBAC Approach	Description	For More Information
No RBAC	Allows you to perform all tasks as superuser. You can log in as yourself. When you select a Solaris management tool, you enter root as the user and the root password.	"How to Become Superuser (root) or Assume a Role" on page 48
Root as a Role	Eliminates anonymous root logins and prevents users from logging in as root. This approach requires users to log in as themselves before they assume the root role. Note that you can apply this technique whether or not you are using other roles.	"Making a Role" in <i>System Administration Guide: Security Services</i>
Single Role Only	Uses the Primary Administrator role, which is roughly equivalent to having root access only.	"Creating the Primary Administrator Role" on page 51
Suggested Roles	Uses three roles that are easily configured: Primary Administrator, System Administrator, and Operator. These roles are appropriate for organizations with administrators at different levels of responsibility whose job capabilities roughly fit the suggested roles.	"Role-Based Access Control (Overview)" in <i>System Administration Guide: Security Services</i>
Custom Roles	You can add your own roles, depending on your organization's security needs.	"Planning for RBAC" in <i>System Administration Guide: Security Services</i>

Becoming Superuser (root) or Assuming a Role

Most administration tasks, such as adding users, file systems, or printers, require that you first log in as root (UID=0) or assume a role if you are using RBAC. The root account, also known as the *superuser* account, is used to make system changes and can override user file protection in emergency situations.

The superuser account and roles should be used only to perform administrative tasks to prevent indiscriminate changes to the system. The security problem associated with the superuser account is that a user has complete access to the system even when performing minor tasks.

In a non-RBAC environment, you can either log into the system as superuser or use the `su` command to change to the superuser account. If RBAC is implemented, you can assume roles through the console or use `su` and specify a role.

When you use the console to perform administration tasks, you can do one of the following:

- Log into the console as yourself and then supply the root user name and password.
- Log into the console as yourself and then assume a role.

A major benefit of RBAC is that roles can be created to give limited access to specific functions only. If you are using RBAC, you can run restricted applications by assuming a role rather than becoming superuser.

For step-by-step instructions on creating the Primary Administrator role, see “How to Create the First Role (Primary Administrator)” on page 53. For an overview on configuring RBAC to use roles, see “Configuring RBAC (Task Map)” in *System Administration Guide: Security Services*.

▼ How to Become Superuser (root) or Assume a Role

Become superuser or assume a role by using one of the following methods. Each method requires that you know either the superuser password or the role password.

1. Become Superuser – Select one of the following to become superuser.

- a. **Log in as a user, start the Solaris Management Console, select a Solaris management tool, and then log in as root.**

This method enables to you perform any management task from the console.

For information on starting the Solaris Management Console, see “How to Start the Solaris Management Console in a Name Service Environment” on page 61.

b. Log in as superuser on the system console.

```
hostname console: root
Password: root-password
#
```

The pound sign (#) is the Bourne shell prompt for the superuser account. This method provides complete access to all system commands and tools.

c. Log in as a user, and then change to the superuser account by using the `su` command at the command line.

```
% su
Password: root-password
#
```

This method provides complete access to all system commands and tools.

d. Log in remotely as superuser. This method is not enabled by default. You must modify the `/etc/default/login` file to remotely log in as superuser on the system console. For information on modifying this file, see “Securing Machines (Tasks)” in *System Administration Guide: Security Services*.

This method provides complete access to all system commands and tools.

2. Assume a Role – Select one of the following to assume a role.

a. Log in as user, and then change to a role by using the `su` command at the command line.

```
% su role
Password: role-password
$
```

This method provides access to all the commands and tools the role has access to.

b. Log in as a user, start the Solaris Management Console, select a Solaris management tool, and then assume a role.

For information on starting the Solaris Management Console, see “How to Start the Console as Superuser or as a Role” on page 54.

This method provides access to the Solaris management tools that the role has access to.

Using the Solaris Management Tools With RBAC (Task Map)

This task map describes the tasks to do if you want to use the Role-Based Access Control (RBAC) security features rather than use the superuser account to perform administration tasks.

Note – The information in this chapter describes how to use the console with RBAC. RBAC overview and task information is included to show you how to initially setup RBAC with the console.

For detailed information on RBAC and using it with other applications, see “Role-Based Access Control (Overview)” in *System Administration Guide: Security Services*.

Task	Description	For Instructions
1. Start the console	If your user account is already set up, start the console as yourself, and then log in to the console as root. If you do not have a user account set up, become superuser first, and then start the console.	“How to Start the Console as Superuser or as a Role” on page 54
2. Add a user account for yourself	Add a user account for yourself if you do not have one already.	Solaris Management Console online help
3. Create the Primary Administrator role	Create the Primary Administrator role and add yourself to this role.	“How to Create the First Role (Primary Administrator)” on page 53
4. Assume the Primary Administrator role	Assume the Primary Administrator role after you have created this role.	“How to Assume the Primary Administrator Role” on page 53
5. (Optional) Make root a role	Make root a role and add yourself to the root role so that no other user can use the su command to become root.	“Making a Role” in <i>System Administration Guide: Security Services</i>

Task	Description	For Instructions
6. (Optional) Create other administrative roles	Create other administrative roles and grant the appropriate rights to each role. Then, add the appropriate users to each role.	"How to Create a Role by Using the Administrative Roles Tool" in <i>System Administration Guide: Security Services</i>

The following sections provide overview information and step-by-step instructions for using the Solaris Management Console and the RBAC security features.

If You Are the First to Log In to the Console

If you are the first administrator to log in to the console, start the console as a user (yourself), and then log in as superuser. This method gives you complete access to all the console tools.

Here are the general steps, depending on whether or not you are using RBAC:

- *Without RBAC* – If you choose not to use RBAC, continue working as superuser. All other administrators will also need root access to perform their jobs.
- *With RBAC* – You'll need to do the following:
 - Set up your user account, if you do not already have one.
 - Create the role called Primary Administrator.
 - Assign the Primary Administrator right to the role you are creating.
 - Assign your user account to this role.

For step-by-step instructions on creating the Primary Administrator role, see "How to Create the First Role (Primary Administrator)" on page 53.

For an overview on configuring RBAC to use roles, see "Configuring RBAC (Task Map)" in *System Administration Guide: Security Services*.

Creating the Primary Administrator Role

An administrative role is a special user account. Users who assume a role are permitted to perform a pre-defined set of administrative tasks.

The Primary Administrator role is permitted to perform all administrative functions, similar to superuser.

If you are superuser, or a user assuming the Primary Administrator role, you can define which tasks other administrators are permitted to perform. With the help of the Add Administrative Role wizard, you can create a role, grant rights to the role, and

then specify which users are permitted to assume that role. A right is a named collection of commands, or authorizations, for using specific applications or for performing specific functions within an application, and other rights, whose use can be granted or denied by an administrator.

You are prompted for the following information when you create the Primary Administrator role:

TABLE 2-2 Item Descriptions for Adding a Role by Using the Console

Item	Description
Role Name	Selects the name an administrator uses to log in to a specific role.
Full Name	Provides a full, descriptive name of this role. (Optional)
Description	Further description of this role.
Role ID Number	Selects the identification number assigned to this role. This number is the same as the set of identifiers for UIDs.
Role Shell	Selects the shell that runs when a user logs into a terminal or console window and assumes a role in that window.
Create a role mailing list	Creates a mailing list with the same name as the role, if checked. You can use this list to send email to everyone assigned to the role.
Role Password and Confirm Password	Sets and confirms the role password and password.
Available Rights and Granted Rights	Assigns rights to this role by choosing from the list of Available Rights and adding them to the list of Granted Rights.
Select a home directory	Selects the home directory server where this role's private files will be stored.
Assign users to this role	Adds specific users to the role so they can assume the role to perform specific tasks.

For detailed information about Role-Based Access Control, and how to use roles to create a more secure environment, see "Role-Based Access Control (Overview)" in *System Administration Guide: Security Services*.

▼ How to Create the First Role (Primary Administrator)

This procedure describes how to create the Primary Administrator role and then assign it to your user account. This procedure assumes that your user account is already created.

1. Start the console as yourself.

```
% /usr/sadm/bin/smc &
```

For additional information on starting the console, see “How to Start the Console as Superuser or as a Role” on page 54.

See the console online help if you need to create a user account for yourself.

2. Click This Computer icon in the Navigation pane.

3. Click System Configuration->Users->Administrative Roles.

4. Click Action->Add Administrative Role.

The Add Administrative Role wizard opens.

5. Create the Primary Administrator role with the Administrative Role wizard by following these steps.

a. Identify the role name, full role name, description, role ID number, role shell, and whether you want to create a role mailing list. Click Next.

b. Set and confirm the role password. Click Next.

c. Select the Primary Administrator right from the Available Rights column and add it to Granted Rights column. Click Next.

d. Select the home directory for the role. Click Next.

e. Assign yourself to the list of users who can assume the role. Click Next.

If necessary, see Table 2-2 for a description of the role items.

6. Click Finish.

▼ How to Assume the Primary Administrator Role

After you have created the Primary Administrator role, log in to the console as yourself, and then assume the Primary Administrator role.

When you assume a role, you take on all the attributes of that role, including the rights. At the same time, you relinquish all of your own user properties.

1. Start the console.

```
% /usr/sadm/bin/smc &
```

For information on starting the console, see “How to Start the Console as Superuser or as a Role” on page 54.

2. **Log in with your user name and password.**
A list shows which roles you are permitted to assume.
3. **Log in to the Primary Administrator role and provide the role password.**

Starting the Solaris Management Console

The following procedure describes how to start the console and gain access to the Solaris management tools.

▼ How to Start the Console as Superuser or as a Role

If you start the console as a user, with your own user account, you have limited access to the Solaris management tools. For greater access, you can log in as yourself and then as one of the roles you are allowed to assume. If you are permitted to assume the role of Primary Administrator, you then have access to all the Solaris management tools, equivalent to that of superuser.

1. **Verify that you are in a window environment, such as the CDE environment.**
2. **Start the console in one of the following ways.**

- From the command line, type:

```
% /usr/sadm/bin/smc &
```

It might take a minute or two for the console to come up the first time.

- From the Tools menu of the CDE front panel.
- By double-clicking a Solaris Management Console icon in CDE’s Applications Manager or File Manager.

The Solaris Management Console window is displayed.

Note – Open a console in your window environment to display the Solaris Management Console start-up messages. Do not attempt to start the Solaris Management Console server manually before starting the Solaris Management Console. The server starts automatically when you start the Solaris Management Console. For information on troubleshooting console problems, see “Troubleshooting the Solaris Management Console” on page 63.

3. Double-click the This Computer icon under the Management Tools icon in the Navigation pane.

A list of categories is displayed.

4. (Optional) Select the appropriate toolbox.

If you want to use a toolbox other than the default toolbox, select the appropriate toolbox from the Navigation pane. Or, select Open Toolbox from the console menu and load the toolbox you want.

For information about using different toolboxes, see “How to Create a Toolbox for a Specific Environment” on page 59.

5. Double-click the category icon to access a particular tool.

Use the online help to identify how to perform a specific task.

6. Double-click the tool icon.

A popup Log-In window is displayed.

7. Decide if you want to the tool as superuser or as a role.

- If you are logging in as superuser and will be working as superuser, select step 8.
- If you are logging in as yourself and will be assuming the Primary Administrator role, select steps 9 and 10.

8. If you are logging in as superuser, enter the root password.

9. If you are logging in as yourself, backspace over the root user name. Then supply your user ID and user password.

A list of roles you can assume is displayed.

10. Select the Primary Administrator role, or an equivalent role, and supply the role password.

For step-by-step instructions on creating the Primary Administrator role, see “How to Create the First Role (Primary Administrator)” on page 53.

The main tool menu is displayed.

Using the Solaris Management Tools in a Name Service Environment (Task Map)

By default, the Solaris management tools are set up to operate in a local environment. For example, the Mounts and Shares tool enables you to mount and share directories on specific systems, but not in a NIS or NIS+ environment. However, you can manage information with the Users and Computers and Networks tools in a name service environment.

To work with a console tool in a name service environment, you need to create a name service toolbox, and then add the tool to that toolbox.

Task	Description	For Instructions
1. Verify prerequisites	Verify you have completed the prerequisites before attempting to use the console in a name service environment.	"Prerequisites for Using the Solaris Management Console in a Name Service Environment" on page 58
2. Create a toolbox for the name service	Use the New Toolbox wizard to create a toolbox for your name service tools.	"How to Create a Toolbox for a Specific Environment" on page 59
3. Add a tool to the name service toolbox	Add the Users tool, or any other name service tool, to your name service toolbox.	"How to Add a Tool to a Toolbox" on page 60
4. Select the toolbox just created	Select the toolbox you just created to manage name service information.	"How to Start the Solaris Management Console in a Name Service Environment" on page 61

RBAC Security Files

The RBAC security files that work with the Solaris Management Console are created when you upgrade to or install the Solaris 9 release. If you do not install the Solaris Management Console packages, the RBAC security files are installed without the necessary data for using RBAC. For information on the Solaris Management Console packages, see "Troubleshooting the Solaris Management Console" on page 63.

The RBAC security files in the Solaris 9 release are included in your name service so that you can use the Solaris Management Console tools in a name service environment.

The security files on a local server are populated into a name service environment as part of a standard upgrade by the `ypmake`, `nispopulate`, or equivalent LDAP commands. The following name services are supported:

- NIS
- NIS+
- LDAP
- files

Note – The `projects` database is not supported in the NIS+ environment.

The RBAC security files are created when you upgrade to or install the Solaris 9 release.

This table briefly describes the pre-defined security files that are installed on a Solaris 9 system.

TABLE 2-3 RBAC Security Files

Local File Name	Table or Map Name	Description
<code>/etc/user_attr</code>	<code>user_attr</code>	Associates users and roles with authorizations and rights profiles.
<code>/etc/security/auth_attr</code>	<code>auth_attr</code>	Defines authorizations and their attributes and identifies associated help files.
<code>/etc/security/prof_attr</code>	<code>prof_attr</code>	Defines rights profiles, lists the rights profiles assigned authorizations and identifies associated help files.
<code>/etc/security/exec_attr</code>	<code>exec_attr</code>	Defines the privileged operations assigned to a rights profile.

For unusual upgrade cases, you might have to use the `smattrpop` command to populate RBAC security files in the following instances:

- When creating or modifying rights profiles, or
- When you need to include users and roles by customizing the `usr_attr` file.

For more information, see “Role-Based Access Control (Overview)” in *System Administration Guide: Security Services*.

Prerequisites for Using the Solaris Management Console in a Name Service Environment

The following table identifies what you need to do before you can use the Solaris Management Console in a name service environment.

Prerequisite	For More Information
Install the Solaris 9 release.	<i>Solaris 9 12/03 Installation Guide</i>
Set up your name service environment.	<i>System Administration Guide: Naming and Directory Services (DNS, NIS, and LDAP)</i>
Select your management scope.	"Management Scope" on page 58
Make sure your <code>/etc/nsswitch.conf</code> file is configured so that you can access your name service data.	"The <code>/etc/nsswitch.conf</code> File" on page 58

Management Scope

The Solaris Management Console uses the term *management scope* to refer to the name service environment that you want to use with the selected management tool. The management scope choices for the Users and Computers and Networks tools are LDAP, NIS, NIS+, or files.

The management scope that you select during a console session should correspond to the primary name service identified in the `/etc/nsswitch.conf` file.

The `/etc/nsswitch.conf` File

The `/etc/nsswitch.conf` file on each system specifies the policy for name service lookups (where data is read from) on that system.

Note – You must make sure that the name service accessed from the console, which you specify through the console Toolbox Editor, appears in the search path of the `/etc/nsswitch.conf` file. If the specified name service does not appear there, the tools might behave in unexpected ways, resulting in errors or warnings.

When using the Solaris managements tools in a name service environment, you might impact many users with a single operation. For example, if you delete a user in the NIS name service, that user is deleted on all systems that are using NIS.

If different systems in your network have different `/etc/nsswitch.conf` configurations, unexpected results might occur. So, all systems to be managed with the Solaris management tools should have a consistent name service configuration.

▼ How to Create a Toolbox for a Specific Environment

Applications for administering the Solaris operating environment are called tools, and those tools are stored in collections referred to as *toolboxes*. A toolbox can be located on a local server, where the console is located, or on a remote machine.

Use the Toolbox Editor to add a new toolbox, to add tools to an existing toolbox, or to change the scope of a toolbox. For example, to change the domain from local files to a name service.

Note – You can start the Toolbox Editor as a normal user. However, if you plan to make changes and save them to the default console toolbox (`/var/sadm/smc/toolboxes`), you must start the Toolbox Editor as `root`.

1. Start the Toolbox Editor.

```
# /usr/sadm/bin/smc edit &
```

2. Select Open from the Toolbox menu.

3. Select the This Computer icon in the Toolboxes: window.

4. Click Open.

The This Computer toolbox opens in the window.

5. Select the This Computer icon again in the Navigation pane.

6. Select Add Folder from the Action menu.

7. Use the Folder wizard to add a new toolbox for your name service environment.

a. Name and Description – Provide a name in the Full Name window. Click Next.

For example, “NIS tools” for the NIS environment.

b. Provide a description in the Description window. Click Next.

For example, “tools for NIS environment.”

c. Icons – Use the default value for the Icons. Click Next.

d. Management Scope – Select Override.

- e. Select your name service under the Management Scope pull-down menu.
- f. Add the name service master name in the Server: field, if necessary.
- g. Add the domain managed by the server in the Domain: field.
- h. Click Finish.

The new toolbox appears in the left Navigation pane.

8. Select the new toolbox icon.
9. Select Save As from the Toolbox menu.
10. Enter the toolbox path name in the Local Toolbox Filename: dialog box. Use the `.tbx` suffix.

```
/var/sadm/smc/toolboxes/this_computer/toolbox-name.tbx
```

11. Click Save.

The new toolbox appears in the Navigation pane in the console window.

Where to Go From Here

After you have created a name service toolbox, you can put a name service tool into it. For more information, see “How to Add a Tool to a Toolbox” on page 60.

▼ How to Add a Tool to a Toolbox

In addition to the default tools that ship with the console, additional tools that can be launched from the console are being developed. As these tools become available, you can add one or more tools to an existing toolbox.

You can also create a new toolbox, for either local management or network management, and then add tools to the new toolbox.

1. Become superuser or assume an equivalent role.
2. Start the Toolbox Editor, if necessary.

```
# /usr/sadm/bin/smc edit &
```

3. Select the toolbox.

If you want to work in a name service, select the toolbox you just created in the Toolbox Editor.

For more information, see “How to Create a Toolbox for a Specific Environment” on page 59.

4. Select Add Tool from the Action menu.

5. **Use the Add Tool wizard to add the new tool.**
 - a. **Server Selection** – Add the name service master in the **Server:** window. Click **Next**.
 - b. **Tools Selection** – Select the tool you want to add from the **Tools:** window. Click **Next**.

If this tool box is a name service toolbox, choose a tool you want to work in a name service environment. For example, the Users Tools.
 - c. **Name and Description** – Accept the default values. Click **Next**.
 - d. **Icons** – Accept the default values, unless you have created custom icons. Click **Next**.
 - e. **Management Scope** – Accept the default value “**Inherit from Parent.**” Click **Next**.
 - f. **Tool Loading** – Accept the default “**Load tool when selected.**” Click **Finish**.
6. **Select Save from the Toolbox menu to save the updated toolbox.**

The Local Toolbox window is displayed.

▼ How to Start the Solaris Management Console in a Name Service Environment

After you have created a name service toolbox and have added tools to it, you can start the Solaris Management Console and open that toolbox to manage a name service environment.

1. **Verify that the following prerequisites are met.**
 - a. **Be sure the system you are logged into is configured to work in a name service environment.**
 - b. **Verify that the `/etc/nsswitch.conf` file is configured to match your name service environment.**
2. **Start the Solaris Management Console.**

For more information, see “How to Start the Console as Superuser or as a Role” on page 54.
3. **Select the toolbox you created for the name service, which appears in the Navigation pane.**

For information on creating a toolbox for a name service, see “How to Create a Toolbox for a Specific Environment” on page 59.

Adding Tools to the Solaris Management Console

This section describes how to add legacy tools or unbundled tools to the console. If you want to add authentication to these tools, see “Securing Legacy Applications” in *System Administration Guide: Security Services*.

▼ How to Add a Legacy Tool to a Toolbox

A legacy tool is any application that was not designed specifically as a Solaris management tool. You can add three types of legacy tool applications, X applications, command-line interface, and HTML, to a console toolbox. Each tool you add to a toolbox can then be launched from the Solaris Management Console.

- 1. Become superuser or assume an equivalent role.**
- 2. Start the Solaris Management Console Toolbox Editor, if necessary.**

```
# /usr/sadm/bin/smc edit &
```
- 3. Open the toolbox to which you want to add the legacy application.**
The toolbox selected is opened in the Toolbox Editor.
- 4. Select the node in the toolbox to which you want to add the legacy application.**
A legacy application can be added to the top node of a toolbox or to another folder.
- 5. Click Action->Add Legacy Application.**
The first panel of the Legacy Application Wizard: General is displayed.
- 6. Follow the instructions in the wizard.**
- 7. Save the toolbox in the Editor.**

▼ How to Install an Unbundled Tool

Follow this procedure if you want to add a new tool package that can be launched from the console.

- 1. Become superuser or assume an equivalent role.**
- 2. Install the new tool package.**

```
# pkgadd ABCDtool
```

3. Restart the console so that it recognizes the new tool.

a. Stop the console server.

```
# /etc/init.d/init.wbem stop
```

b. Start the console server.

```
# /etc/init.d/init.wbem start
```

4. Start the console to verify that the new tool is displayed.

For more information, see “How to Start the Console as Superuser or as a Role” on page 54.

Troubleshooting the Solaris Management Console

Before using this troubleshooting procedure, make sure the following packages are installed:

SUNWmc	Solaris Management Console 2.1 (Server Components)
SUNWmcc	Solaris Management Console 2.1 (Client Components)
SUNWmccom	Solaris Management Console 2.1 (Common Components)
SUNWmcdev	Solaris Management Console 2.1 (Development Kit)
SUNWmcex	Solaris Management Console 2.1 (Examples)
SUNWwbmc	Solaris Management Console 2.1 (WBEM Components)

These packages provide the basic Solaris Management Console launcher. You must install the SUNWprog cluster to use the Solaris Management Console and all of its tools.

▼ How to Troubleshoot the Solaris Management Console

The client and the server are started automatically when you start the Solaris Management Console.

If the console is visible and you are having trouble running the tools, it might be that the server is not running. Or, the server might be in a problem state that can be resolved by stopping and restarting it.

- 1. Become superuser or assume an equivalent role.**
- 2. Determine whether the console server is running.**

```
# /etc/init.d/init.wbem status
```

If the console server is running, you should see a message like the following:

```
SMC server version 2.1.0 running on port 898.
```

3. If the console server is not running, start it.

```
# /etc/init.d/init.wbem start
```

After a short time, you should see a message like the following:

```
SMC server is ready.
```

4. If the server is running and you are still having problems, stop the console server and then restart it.

a. Stop the console server.

```
# /etc/init.d/init.wbem stop
```

You should see a message like the following:

```
Shutting down SMC server on port 898.
```

b. Start the console server.

```
# /etc/init.d/init.wbem start
```

Managing Users and Groups Topics

This topic map lists the chapters that provide information on managing users and groups.

Chapter 4	Provides overview information about managing user accounts and groups.
Chapter 5	Provides step-by-step instructions for managing user accounts and groups.

Managing User Accounts and Groups (Overview)

This chapter provides guidelines and planning information for managing user accounts and groups. This chapter also includes information about customizing the user's work environment.

This is a list of the overview information in this chapter.

- "What's New in Managing Users and Groups?" on page 67
- "What Are User Accounts and Groups?" on page 69
- "Guidelines for Managing User Accounts" on page 70
- "Guidelines for Managing Groups" on page 76
- "Tools for Managing User Accounts and Groups" on page 77
- "Where User Account and Group Information Is Stored" on page 83
- "Customizing a User's Work Environment" on page 88

For step-by-step instructions on managing user accounts and groups, see Chapter 5.

What's New in Managing Users and Groups?

This section describes new features for managing users and groups in the Solaris 9 release.

Solaris Management Console Tools Suite

The Solaris Management tools suite, available from the Solaris Management Console, enable you to manage all user and group features. For information on using the Solaris Management Console, see Chapter 2. For information on performing specific user and group management tasks, see “What You Can Do With Solaris User Management Tools” on page 78.

Solaris Directory Services

You can manage user and group information in a LDAP (Lightweight Directory Access Protocol) directory service with the iPlanet™ Directory Server, as well as other LDAP directory servers. Managing user and group information is also available in the NIS, NIS+, or files environment.

For information on setting up LDAP, see *System Administration Guide: Naming and Directory Services (DNS, NIS, and LDAP)*.

For information on managing users and groups with iPlanet Directory Server, see *iPlanet Directory Server 5.1 Administrator's Guide* at the <http://docs.sun.com/db/doc/816-2670?site>.

Managing Users and Resources With Projects

In the Solaris 9 release, users and groups can be members of a *project*, an identifier that indicates a workload component that can be used as the basis of system usage or resource allocation chargeback. Projects are part of the Solaris resource management feature that is used to manage system resources.

Users need to be a member of a project to successfully log in to a system running the Solaris 9 release. By default, users are a member of the `group.staff` project when the Solaris 9 release is installed and no other project information is configured.

User project information is stored in the `/etc/project` file, which can be stored on the local system (files), the NIS name service, or the LDAP directory service. You can use the Solaris Management Console to manage project information.

The `/etc/project` file must exist for users to log in successfully, but requires no administration if you are not using projects.

For more information on using or setting up projects, see “Projects and Tasks” in *System Administration Guide: Resource Management and Network Services*.

What Are User Accounts and Groups?

One basic system administration task is to set up a user account for each user at a site. A typical user account includes the information a user needs to log in and use a system, without having the system's root password. User account information has the following components:

Component	Description
User name	A name that a user uses to log in to a system. This name is also known as a login name.
Password	A secret combination of characters that a user must enter with a user name to gain access to a system.
User's home directory	A directory that is usually the user's current directory at login. The user's home directory typically contains most of the user's files.
User initialization files	Shell scripts that control how the user's working environment is set up when a user logs in to a system.

Also, when you set up a user account, you can add the user to predefined groups of users. A typical use of groups is to set up group permissions on a file and directory, which allows access only to users who are part of that group.

For example, you might have a directory containing confidential files that only a few users should be able to access. You could set up a group called `topsecret` that includes the users working on the `topsecret` project. And, you could set up the `topsecret` files with read permission for the `topsecret` group. That way, only the users in the `topsecret` group would be able to read the files.

A special type of user account, called a *role*, is used to give selected users special privileges. For more information, see "Role-Based Access Control (Overview)" in *System Administration Guide: Security Services*.

A user or group can be a member of one or more projects. A project is an identifier that is used to chargeback system resources. For information on using projects, see "Projects and Tasks" in *System Administration Guide: Resource Management and Network Services*.

Guidelines for Managing User Accounts

The following sections describe some guidelines and planning information for creating user accounts.

Name Services

If you are managing user accounts for a large site, you might want to consider using a name or directory service such as LDAP, NIS, or NIS+. A name or directory service enables you to store user account information in a centralized manner instead of storing user account information in every system's `/etc` files. When using a name or directory service for user accounts, users can move from system to system using the same user account without having site-wide user account information duplicated on every system. Using a name or directory service also promotes centralized and consistent user account information.

User (Login) Names

User names, also called login names, let users access their own systems and remote systems that have the appropriate access privileges. You must choose a user name for each user account you create.

Keep the following guidelines in mind when creating user or role names:

- Be unique within your organization, which might span multiple domains
- Contain from two to eight letters and numerals. The first character should be a letter and at least one character should be a lowercase letter.

Even though user names can include a period (`.`), underscore (`_`), or hyphen (`-`), using these characters is not recommended because they can cause problems with some software products.

Consider establishing a standard way of assigning user names so they are easier for you to track. Also, names should be easy for users to remember. A simple scheme when selecting a user name is to use the first name initial and first seven letters of the user's last name. For example, Ziggy Ignatz becomes `zignatz`. If this scheme results in duplicate names, you can use the first initial, middle initial, and the first six characters of the user's last name. For example, Ziggy Top Ignatz becomes `ztignatz`. If this scheme still results in duplicate names, consider using the following scheme:

- The first initial, middle initial, first five characters of the user's last name,
- and the number 1, or 2, or 3, and so on, until you have a unique name.

Note – Each new user name must be distinct from any mail aliases known to the system or to an NIS or NIS+ domain. Otherwise, mail might be delivered to the alias rather than to the actual user.

User ID Numbers

Associated with each user name is a user identification (UID) number. The user UID identifies the user name to any system on which the user attempts to log in. And, the user UID is used by systems to identify the owners of files and directories. If you create user accounts for a single individual on a number of different systems, always use the same user name and user ID. In that way, the user can easily move files between systems without ownership problems.

UID numbers must be a whole number less than or equal to 2147483647. UID numbers are required for both regular user accounts and special system accounts. The following table lists the UID numbers reserved for user accounts and system accounts.

TABLE 4-1 Reserved UID Numbers

User ID Numbers	Use or Login Accounts	Description
0 - 99	root, daemon, bin, sys, and so on.	System accounts
100 - 2147483647	Regular users	General purpose accounts
60001 and 65534	nobody and nobody4	Anonymous users
60002	noaccess	Non-trusted users

Although UID numbers 0 through 99 are reserved, you can add a user with one of these numbers. However, do not use 0 through 99 for regular user accounts. By definition, root always has UID 0, daemon has UID 1, and pseudo-user bin has UID 2. In addition, you should give uucp logins and pseudo user logins, like who, tty, and ttytype, low UIDs so they fall at the beginning of the passwd file.

As with user (login) names, you should adopt a scheme to assign unique UIDs. Some companies assign unique employee numbers, and administrators add a number to the employee number to create a unique UID number for each employee.

To minimize security risks, you should avoid reusing the UIDs from deleted accounts. If you must reuse a UID, “wipe the slate clean” so the new user is not affected by attributes set for a former user. For example, a former user might have been denied access to a printer by being included in a printer deny list, but that attribute might not be appropriate for the new user.

Using Large User IDs and Group IDs

UIDs and GIDs can be assigned up to the maximum value of a signed integer, or 2147483647.

However, UIDs and GIDs over 60000 do not have full functionality and are incompatible with many Solaris features, so avoid using UIDs or GIDs over 60000.

The following table describes interoperability issues with Solaris products and previous Solaris releases.

TABLE 4-2 Interoperability Issues for UIDs or GIDs Over 60000

Category	Product or Command	Issues or Cautions
NFS™ Interoperability	SunOS™ 4.0 NFS software and compatible releases	NFS server and client code truncates large UIDs and GIDs to 16 bits. This situation can create security problems if systems running SunOS 4.0 and compatible releases are used in an environment where large UIDs and GIDs are being used. Systems running SunOS 4.0 and compatible releases require a patch to avoid this problem.
Name Service Interoperability	NIS name service and file-based name service	Users with UIDs greater than 60000 can log in or use the <code>su</code> command on systems running the Solaris 2.5 and compatible releases, but their UIDs and GIDs will be set to 60001 (<code>nobody</code>).
	NIS+ name service	Users with UIDs greater than 60000 are denied access on systems running Solaris 2.5 and compatible releases and the NIS+ name service.

TABLE 4-3 Large UID or GID Limitation Summary

UID or GID	Limitations
60003 or greater	■ Users in this category logging into systems running Solaris 2.5 and compatible releases and the NIS or files name service get a UID and GID of <code>nobody</code> .

TABLE 4-3 Large UID or GID Limitation Summary (Continued)

UID or GID	Limitations
65535 or greater	<ul style="list-style-type: none"> ■ Systems running Solaris 2.5 and compatible releases with the NFS version 2 software see UIDs in this category truncated to 16 bits, creating possible security problems. ■ Users in this category using the <code>cpio</code> command with the default archive format to copy a file see an error message for each file. And, the UIDs and GIDs are set to <code>nobody</code> in the archive. ■ SPARC based systems: Users in this category running SunOS 4.0 and compatible applications see <code>EOverflow</code> returns from some system calls, and their UIDs and GIDs are mapped to <code>nobody</code>. ■ x86 based systems: Users in this category running SVR3-compatible applications will probably see <code>EOverflow</code> return codes from system calls. ■ x86 based systems: If users in this category attempt to create a file or directory on a mounted System V file system, the System V file system returns an <code>EOverflow</code> error.
100000 or greater	<ul style="list-style-type: none"> ■ The <code>ps -l</code> command displays a maximum five-digit UID so the printed column won't be aligned when they include a UID or GID larger than 99999.
262144 or greater	<ul style="list-style-type: none"> ■ Users in this category using the <code>cpio</code> command with the <code>-H odc</code> format or the <code>pax -x cpio</code> command to copy files see an error message returned for each file. And, the UIDs and GIDs are set to <code>nobody</code> in the archive.
1000000 or greater	<ul style="list-style-type: none"> ■ Users in this category using the <code>ar</code> command have their UIDs and GIDs set to <code>nobody</code> in the archive.
2097152 or greater	<ul style="list-style-type: none"> ■ Users in this category using the <code>tar</code> command, the <code>cpio -H ustar</code> command, or the <code>pax -x tar</code> command have their UIDs and GIDs set to <code>nobody</code>.

Passwords

You can specify a password for a user when you add the user. Or, you can force the user to specify a password when the user first logs in. User passwords must comply with the following syntax:

- Password length must at least match the value identified by the `PASSLENGTH` variable in the `/etc/default/passwd` file. By default, `PASSLENGTH` is set to 6.
- The first 6 characters of the password must contain at least two alphabetic characters and have at least one numeric or special character.

Although user names are publicly known, passwords must be kept secret and known only to users. Each user account should be assigned a password, which is a combination of six to eight letters, numbers, or special characters.

To make your computer systems more secure, ask users to change their passwords periodically. For a high level of security, you should require users to change their passwords every six weeks. Once every three months is adequate for lower levels of security. System administration logins (such as root and sys) should be changed monthly, or whenever a person who knows the root password leaves the company or is reassigned.

Many breaches of computer security involve guessing a legitimate user's password. You should make sure that users avoid using proper nouns, names, login names, and other passwords that a person might guess just by knowing something about the user.

Good choices for passwords include the following:

- Phrases (beammeup)
- Nonsense words made up of the first letters of every word in a phrase. For example, *swotr*b for SomeWhere Over The RainBow.
- Words with numbers or symbols substituted for letters. For example, *sn00py* for snoopy.

Do not use these choices for passwords:

- Your name, forwards, backwards, or jumbled
- Names of family members or pets
- Car license numbers
- Telephone numbers
- Social Security numbers
- Employee numbers
- Names related to a hobby or interest
- Seasonal themes, such as Santa in December
- Any word in the dictionary

Password Aging

If you are using NIS+ or the */etc* files to store user account information, you can set up password aging on a user's password. Starting in the Solaris 9 12/02 release, password aging is also supported in the LDAP directory service.

Password aging enables you to force users to change their passwords periodically or to prevent a user from changing a password before a specified interval. If you want to prevent an intruder from gaining undetected access to the system by using an old and inactive account, you can also set a password expiration date when the account becomes disabled. You can set password aging attributes with the *passwd* command or the Solaris Management Console's Users Tool.

Home Directories

The home directory is the portion of a file system allocated to a user for storing private files. The amount of space you allocate for a home directory depends on the kinds of files the user creates, large or small, and the number of files created.

A home directory can be located either on the user's local system or on a remote file server. In either case, by convention the home directory should be created as `/export/home/username`. For a large site, you should store home directories on a server. Use a separate file system for each `/export/home` directory to facilitate backing up and restoring home directories. For example, `/export/home1`, `/export/home2`.

Regardless of where their home directory is located, users usually access their home directories through a mount point named `/home/username`. When AutoFS is used to mount home directories, you are not permitted to create any directories under the `/home` mount point on any system. The system recognizes the special status of `/home` when AutoFS is active. For more information about automounting home directories, see "Task Overview for Autofs Administration" in *System Administration Guide: Resource Management and Network Services*.

To use the home directory anywhere on the network, you should always refer to the home directory as `$HOME`, not as `/export/home/username`. The latter is machine-specific. In addition, any symbolic links created in a user's home directory should use relative paths (for example, `../..../x/y/x`), so the links will be valid no matter where the home directory is mounted.

User's Work Environment

Besides having a home directory to create and store files, users need an environment that gives them access to the tools and resources they need to do their work. When a user logs in to a system, the user's work environment is determined by initialization files that are defined by the user's startup shell, such as the C, Korn, or Bourne shell.

A good strategy for managing the user's work environment is to provide customized user initialization files, such as `.login`, `.cshrc`, `.profile`, in the user's home directory. For detailed information about customizing user initialization files for users, see "Customizing a User's Work Environment" on page 88. After you create the customized user initialization files, you can add them to a user's home directory when you create a new user account.

A recommended one-time task is to set up *skeleton* directories on a server. You can use the same server where the user's home directories are stored. The skeleton directories enable you to store customized user initialization files for different types of users.

Note – Do not use system initialization files, such as `/etc/profile` or `/etc/.login`, to manage a user’s work environment, because they reside locally on systems and are not centrally administered. For example, if AutoFS is used to mount the user’s home directory from any system on the network, you would have to modify the system initialization files on each system to ensure a consistent environment when a user moved from system to system.

Another way to customize user accounts is through role-based access control. See “Role-Based Access Control (Overview)” in *System Administration Guide: Security Services* for more information.

Guidelines for Managing Groups

A *group* is a collection of users who can share files and other system resources. For example, a set of users that are working on the same project could be formed into a group. A group is traditionally known as a UNIX group.

Each group must have a name, a group identification (GID) number, and a list of user names that belong to the group. A GID identifies the group internally to the system. The two types of groups that a user can belong to are:

- Primary group – Specifies a group that the operating system assigns to files created by the user. Each user must belong to a primary group.
- Secondary groups – Specifies one or more groups to which a user also belongs. Users can belong to up to 15 secondary groups.

Sometimes a user’s secondary group is not important. For example, ownership of files reflect the primary group, not any secondary groups. Other applications, however, might rely on a user’s secondary memberships. For example, a user has to be a member of the `sysadmin` group (group 14) to use the `Admintool` software, but it doesn’t matter if group 14 is his or her current primary group.

The `groups` command lists the groups that a user belongs to. A user can have only one primary group at a time. However, a user can temporarily change the user’s primary group, with the `newgrp` command, to any other group in which the user is a member.

When adding a user account, you must assign a primary group for a user or accept the default group, `staff` (group 10). The primary group should already exist. If the primary group does not exist, specify the group by a GID number. User names are not added to primary groups. If user names were, the list might become too long. Before you can assign users to a new secondary group, you must create the group and assign it a GID number.

Groups can be local to a system or can be managed through a name service. To simplify group administration, you should use a name service like NIS or a directory service like LDAP, which enables you to centrally manage group memberships.

Tools for Managing User Accounts and Groups

The following table lists the recommended tools for managing users and groups. These tools are all included in the Solaris Management Console suite of tools. For information about starting and using the Solaris Management Console, see Chapter 2.

TABLE 4-4 Tools for Managing Users and Groups

Solaris Management Tool	Is Used To	Task Information
Users	Manage users.	Solaris Management Console Online Help
User Templates	Create a set of attributes for a specific kind of user like students, engineers, or instructors.	Solaris Management Console Online Help
Rights	Manage RBAC rights.	Solaris Management Console Online Help
Administrative Roles	Manage RBAC administrative roles.	Solaris Management Console Online Help
Groups	Manage group information.	Solaris Management Console Online Help
Projects	Manage project information.	Solaris Management Console Online Help
Mailing Lists	Manage mailing lists.	Solaris Management Console Online Help

For information on the Solaris management commands that can be used to manage user accounts and groups if you are not using the Solaris Management Console, see Table 1-6. These commands provide the same functionality as the Solaris management tools, including authentication and name service support.

What You Can Do With Solaris User Management Tools

The Solaris user management tools enable you to manage user accounts on a local system or in a name service environment.

This table describes the tasks you can do with Users Tool's User Accounts feature.

TABLE 4-5 User Account Management Tasks

Task	Description	Background Information
Add a user	You can add a user to the local system or name service.	"What Are User Accounts and Groups?" on page 69 and "Guidelines for Managing User Accounts" on page 70
Create a user Template	You can create a template of pre-defined user attributes for creating users of the same group, such a users, contractors, or engineers.	Same as above
Add a user with a user template	You can add a user with a template so that user attributes are pre-defined.	Same as above
Clone a user template	Clone a user template if you would like to use a similar set of pre-defined user attributes. Then, change only some of the attributes as needed.	Same as above
Set up user properties	You can set up user properties in advance of adding users such as whether a user template is used when adding a user and whether the home directory or mail box is deleted by default when removing a user.	Same as above

TABLE 4-5 User Account Management Tasks (Continued)

Task	Description	Background Information
Add multiple users	You can add multiple users to the local system or name service by specifying a text file, typing each name, or automatically generating a series of user names.	Same as above
View or change user properties	You can view or change user properties like login shell, password, or password options.	Same as above
Assign rights to users	You can assign rights to users that will allow them to perform specific administration tasks.	Same as above
Remove a user	You can remove the user from the local system or the name service and optionally specify whether the user's home directory or mail is removed. The user is also removed from any groups or roles.	Same as above

TABLE 4-6 User Rights Management Tasks

Task	Description	Background Information
Grant a right	You can grant a user a right to run a specific command or application that was previously only available to an administrator.	"RBAC Rights Profiles" in <i>System Administration Guide: Security Services</i>
View or change existing rights Properties	You can view or change existing rights.	Same as above
Add an authorization	You can add an authorization, which is a discrete right granted to a role or a user.	"RBAC Authorizations" in <i>System Administration Guide: Security Services</i>
View or change an authorization	You can view or change existing authorizations.	Same as above

TABLE 4-7 User Role Management Tasks

Task	Description	Background Information
Add an administrative role	You can add a role that someone would use to perform a specific administrative task.	"RBAC Roles" in <i>System Administration Guide: Security Services</i>

TABLE 4-7 User Role Management Tasks (Continued)

Task	Description	Background Information
Assign rights to an administrative role	You can assign specific rights to a role that enable someone to perform a task.	Same as above
Change an administrative role	You can add or remove rights from a role.	Same as above

TABLE 4-8 Group Management Tasks

Task	Description	Background Information
Add a group	Add a group to the local system or name service so that the group name is available before you add the user.	"Guidelines for Managing Groups" on page 76
Add a user to a group	Add a user to a group if the user needs access to group-owned files.	Same as above
Remove a user from a group	You can remove a user from a group if the user no longer requires group file access.	Same as above

TABLE 4-9 Project Management Tasks

Task	Description	Background Information
Create or clone a project	You can create a new project or clone an existing project if it has attributes similar to what you need for the new project.	Solaris Management Console online help
Modify or view project attributes	You can view or change existing project attributes.	Solaris Management Console online help
Delete a project	You can remove a project if it is no longer used.	Solaris Management Console online help

TABLE 4-10 Mailing List Management Tasks

Task	Description	Background Information
Create a mailing list	You can create a mailing list, which is a list of names for sending email messages.	Solaris Management Console online help

TABLE 4-10 Mailing List Management Tasks (Continued)

Task	Description	Background Information
Change a mailing list name	You can make changes to the mailing list after it is created.	Solaris Management Console online help
Remove a mailing list	You can remove a mailing list if it is no longer used.	Solaris Management Console online help

Managing Home Directories With the Solaris Management Console

Keep the following in mind when using the Solaris Management Console tools to manage user home directories:

- If you use the Users Tool's Add User Wizard to add a user account and you specify the user's home directory as `/export/home/username`, the home directory is automatically setup to be automounted, and the following entry is added to the `passwd` file:

```
/home/username
```

- The only way you can use Users Tool to set up a user account that does not automount the home directory is to set up a user account template that disables this feature. Then, you can add users with this template. There is no way to disable this feature with the Add User Wizard.
- You can use the `smuser add` command with the `-x autohome=N` option to add a user without automounting the user's home directory. However, there is no option to the `smuser delete` command to remove the home directory after the user is added. You would have to remove the user and the user's home directory with the Users Tool.

Modify User Accounts

Unless you define a user name or UID number that conflicts with an existing one, you should never need to modify a user account's login name or UID number. Use the following steps if two user accounts have duplicate user names or UID numbers:

- If two user accounts have duplicate UID numbers, use the Users Tool to remove one account and re-add it with a different UID number. You cannot use the Users Tool to modify a UID number of an existing user account.
- If two user accounts have duplicate user names, use the Users Tool to modify one of the accounts and change the user name.

If you do use the Users Tool to change a user name, the home directory's ownership is changed, if a home directory exists for the user.

One part of a user account that you can change is a user's group memberships. Select Properties from Users Tool's Action menu to add or delete a user's secondary groups. Alternatively, you can use the Groups Tool to directly modify a group's member list.

You can also modify the following parts of a user account:

- Description (comment)
- Login shell
- Passwords and password options
- Home directory and home directory access
- Rights and roles

Delete User Accounts

When you delete a user account with the Users Tool, the software deletes the entries in the `passwd` and `group` files. In addition, you can delete the files in the user's home directory and mail directory.

Add Customized User Initialization Files

Although you cannot create customized user initialization files with the Users Tool, you can populate a user's home directory with user initialization files located in a specified "skeleton" directory. You can do this by creating a user template with the User Templates tool and specifying a skeleton directory from which to copy user initialization files.

You can customize the user initialization templates in the `/etc/skel` directory and then copy them to users' home directories.

Administer Passwords

You can use Users Tool for password administration, which includes the following capabilities:

- Specifying a normal password for a user account
- Enabling users to create their own passwords during their first login
- Disabling or locking a user account
- Specifying expiration dates and password aging information.

Note – Password aging is not supported by the NIS name service.

Disable User Accounts

Occasionally, you might need to temporarily or permanently disable a login account. Disabling or locking a user account means that an invalid password, *LK*, is assigned to the user account, preventing future logins.

The easiest way to disable a user account is to lock the password for an account with Users Tool.

You can also enter an expiration date in the account availability section of the User Properties screen to set a limit on how long the account is active.

Other ways to disable a user account is to set up password aging or to change the user's password.

Where User Account and Group Information Is Stored

Depending on your site policy, you can store user account and group information in a name service or a local system's `/etc` files. In the NIS+ name service, information is stored in tables, in the NIS name service, information is stored in maps, and in the LDAP directory service, information is stored in indexed database files.

Note – To avoid confusion, the location of the user account and group information is generically referred to as a *file* rather than as a *database*, *table* or *map*.

Most of the user account information is stored in the `passwd` file. However, password encryption and password aging is stored in the `passwd` file when using NIS or NIS+ and in the `/etc/shadow` file when using `/etc` files. Password aging is not available when using NIS.

Group information is stored in the `group` file.

Fields in the `passwd` File

The fields in the `passwd` file are separated by colons and contain the following information:

```
username : password : uid : gid : comment : home-directory : login-shell
```

For example:

kryten:x:101:100:Kryten Series 4000 Mechanoid:/export/home/kryten:/bin/csh

The following table describes the `passwd` file fields.

TABLE 4-11 Fields in the `passwd` File

Field Name	Description
<i>username</i>	Contains the user or login name. User names should be unique and consist of 1-8 letters (A-Z, a-z) and numerals (0-9). The first character must be a letter, and at least one character must be a lowercase letter.
<i>password</i>	Contains an <code>x</code> , a placeholder for the encrypted password. The encrypted password is stored in the <code>shadow</code> file.
<i>uid</i>	Contains a user identification (UID) number that identifies the user to the system. UID numbers for regular users should range from 100 to 60000. All UID numbers should be unique.
<i>gid</i>	Contains a group identification (GID) number that identifies the user's primary group. Each GID number must be a whole number between 0 and 60002. 60001 and 60002 are assigned to <code>nobody</code> and <code>noaccess</code> . 65534 is assigned to <code>nobody4</code> .
<i>comment</i>	Usually contains the full name of the user. This field is informational only. It is sometimes called the GECOS field because it was originally used to hold the login information needed to submit batch jobs to a mainframe running GECOS (General Electric Computer Operating System) from UNIX systems at Bell Labs.
<i>home-directory</i>	Contains the user's home directory path name.
<i>login-shell</i>	Contains the user's default login shell, such as <code>/bin/sh</code> , <code>/bin/csh</code> or <code>/bin/ksh</code> . Table 4-18 contains a description of shell features.

Default `passwd` File

The default Solaris `passwd` file contains entries for standard daemons, processes usually started at boot time to perform some system-wide task, such as printing, network administration, and port monitoring.

```
root:x:0:1:Super-User:/:/sbin/sh
daemon:x:1:1:/:
bin:x:2:2:/:usr/bin:
sys:x:3:3:/:
adm:x:4:4:Admin:/var/adm:
lp:x:71:8:Line Printer Admin:/usr/spool/lp:
uucp:x:5:5:uucp Admin:/usr/lib/uucp:
nuucp:x:9:9:uucp Admin:/var/spool/uucppublic:/usr/lib/uucp/uucico
smmsp:x:25:25:SendMail Message Submission Program:/
```

```
listen:x:37:4:Network Admin:/usr/net/nls:
nobody:x:60001:60001:Nobody:/:
noaccess:x:60002:60002:No Access User:/:
nobody4:x:65534:65534:SunOS 4.x Nobody:/:
```

TABLE 4-12 Default passwd File Entries

User Name	User ID	Description
root	0	Superuser account.
daemon	1	Umbrella system daemon associated with routine system tasks.
bin	2	Administrative daemon associated with running system binaries to perform some routine system task.
sys	3	Administrative daemon associated with system logging or updating files in temporary directories.
adm	4	Administrative daemon associated with system logging.
lp	71	Line printer daemon.
uucp	5	Daemon associated with uucp functions.
nuucp	6	Daemon associated with uucp functions.
smmsp	25	Sendmail message submission program daemon.
listen	37	Network listener daemon.
nobody	60001	Assigned to users or software processes that do not need nor should have any special permissions.
noaccess	60002	Assigned to a user or a process that needs access to a system through some application but without actually logging in.
nobody4	65534	SunOS 4.0 or 4.1 version of the nobody user account.

Fields in the shadow File

The fields in the shadow file are separated by colons and contain the following information:

username : password : lastchg : min : max : warn : inactive : expire

For example:

rimmer:86Kg/MNT/dGu.:8882:0::5:20:8978

The following table describes the `shadow` file fields.

TABLE 4-13 Fields in the `shadow` File

Field Name	Description
<i>username</i>	Contains the user or login name.
<i>password</i>	Might contain the following entries: a 13-character encrypted user password; the string <code>*LK*</code> , which indicates an inaccessible account; or the string <code>NP</code> , which indicates no password for the account.
<i>lastchg</i>	Indicates the number of days between January 1, 1970, and the last password modification date.
<i>min</i>	Contains the minimum number of days required between password changes.
<i>max</i>	Contains the maximum number of days the password is valid before the user is prompted to specify a new password.
<i>inactive</i>	Contains the number of days a user account can be inactive before being locked.
<i>expire</i>	Contains the absolute date when the user account expires. Past this date, the user cannot log in to the system.

Fields in the `group` File

The fields in the `group` file are separated by colons and contain the following information:

group-name : *group-password* : *gid* : *user-list*

For example:

`bin::2:root,bin,daemon`

The following table describes the `group` file fields.

TABLE 4-14 Fields in the `group` File

Field Name	Description
<i>group-name</i>	Contains the name assigned to the group. For example, members of the chemistry department in a university might be called <code>chem</code> . Group names can have a maximum of eight characters.

TABLE 4-14 Fields in the `group` File (Continued)

Field Name	Description
<code>group-password</code>	Usually contains an asterisk or is empty. The <code>group-password</code> field is a relic of earlier versions of UNIX. If a group has a password, the <code>newgrp</code> command prompts users to enter the password. However, no utility exists to set the password.
<code>gid</code>	Contains the group's GID number. It must be unique on the local system, and should be unique across the entire organization. Each GID number must be a whole number between 0 and 60002. Numbers under 100 are reserved for system default group accounts. User defined groups can range from 100 to 60000. 60001 and 60002 are reserved and assigned to <code>nobody</code> and <code>noaccess</code> , respectively.
<code>user-list</code>	Contains a comma-separated list of user names, representing the user's secondary group memberships. Each user can belong to a maximum of 15 secondary groups.

Default group file

The default Solaris `group` file contains the following system groups that support some system-wide task, such as printing, network administration, and electronic mail. Many of these groups having corresponding entries in the `passwd` file.

```

root::0:root
other::1:
bin::2:root,bin,daemon
sys::3:root,bin,sys,adm
adm::4:root,adm,daemon
uucp::5:root,uucp
mail::6:root
tty::7:root,adm
lp::8:root,lp,adm
nuucp::9:root,nuucp
staff::10:
daemon::12:root,daemon
smmsp::25:smmsp
sysadmin::14:root
nobody::60001:
noaccess::60002:
nogroup::65534:

```

TABLE 4-15 Default group File Entries

Group Name	Group ID	Description
<code>root</code>	0	Superuser group.
<code>other</code>	1	Optional group.

TABLE 4-15 Default group File Entries (Continued)

Group Name	Group ID	Description
bin	2	Administrative group associated with running system binaries.
sys	3	Administrative group associated with system logging or temporary directories.
adm	4	Administrative group associated with system logging.
uucp	5	Group associated with uucp functions.
mail	6	Electronic mail group.
tty	7	Group associated with tty devices.
lp	8	Line printer group.
nuucp	9	Group associated with uucp functions.
staff	10	General administrative group.
daemon	12	Group associated with routine system tasks.
sysadmin	14	Administrative group associated with Admintool and Solstice AdminSuite tools.
smmsp	25	Sendmail message submission program daemon.
nobody	60001	Group assigned to users or software processes that do not need nor should have any special permissions.
noaccess	60002	Group assigned to a user or a process that needs access to a system through some application but without actually logging in.
nogroup	65534	Group assigned to a user who not a member of a known group.

Customizing a User's Work Environment

Part of setting up a user's home directory is providing user initialization files for the user's login shell. A *user initialization file* is a shell script that sets up a work environment for a user after the user logs in to a system. Basically, you can perform any task in a user initialization file that you can do in a shell script. However, its primary job is to define the characteristics of a user's work environment, such as a user's search path, environment variables, and windowing environment. Each login shell has its own user initialization file or files, which are listed in the following table.

TABLE 4-16 User Initialization Files for Bourne, C, and Korn Shells

Shell	User Initialization File	Purpose
Bourne	\$HOME/.profile	Defines user's environment at login
C	\$HOME/.cshrc	Defines user's environment for all C shells and is invoked after login shell
	\$HOME/.login	Defines user's environment at login
Korn	\$HOME/.profile	Defines user's environment at login
	\$HOME/\$ENV	Defines user's environment at login in the file and is specified by the Korn shell's ENV environment variable

The Solaris environment provides default user initialization files for each shell in the `/etc/skel` directory on each system, as shown in the following table.

TABLE 4-17 Default User Initialization Files

Shell	Default File
C	<code>/etc/skel/local.login</code>
	<code>/etc/skel/local.cshrc</code>
Bourne or Korn	<code>/etc/skel/local.profile</code>

You can use these files as a starting point and modify them to create a standard set of files that provide the work environment common to all users. Or, you can modify them to provide the working environment for different types of users. For step-by-step instructions on how to create sets of user initialization files for different types of users, see "How to Customize User Initialization Files" on page 103.

When you use the Users Tool to create a new user account and select the create home directory option, the following files are created, depending on which login shell is selected:

Shell	Files Created
C	The <code>/etc/skel/local.cshrc</code> and the <code>/etc/skel/local.login</code> files are copied into the user's home directory and are renamed <code>.cshrc</code> and <code>.login</code> .
Bourne and Korn	The <code>/etc/skel/local.profile</code> file is copied into the user's home directory and renamed <code>.profile</code> .

If you use the `useradd` command to add a new user account and specify the `/etc/skel` directory by using the `-k` and `-m` options, all three `/etc/skel/local*` and `/etc/skel/.profile` files are copied into the user's home directory. At this point, you will need to rename them to whatever is appropriate for the user's login shell.

Using Site Initialization Files

The user initialization files can be customized by both the administrator and the user. This important feature can be accomplished with centrally located and globally distributed user initialization files, called site initialization files. Site initialization files enable you to continually introduce new functionality to the user's work environment, while enabling the user to customize the user's initialization file.

When you reference a site initialization file in a user initialization file, all updates to the site initialization file are automatically reflected when the user logs in to the system or when a user starts a new shell. Site initialization files are designed for you to distribute site-wide changes to users' work environments that you did not anticipate when you added the users.

Any customization that can be done in a user initialization file can be done in a site initialization file. These files typically reside on a server, or set of servers, and appear as the first statement in a user initialization file. Also, each site initialization file must be the same type of shell script as the user initialization file that references it.

To reference a site initialization file in a C-shell user initialization file, place a line similar to the following at the beginning of the user initialization file:

```
source /net/machine-name/export/site-files/site-init-file
```

To reference a site initialization file in a Bourne- or Korn-shell user initialization file, place a line similar to the following at the beginning of the user initialization file:

```
./net/machine-name/export/site-files/site-init-file
```

Avoid Local System References

You should not add specific references to the local system in the user's initialization file. You want the instructions in a user initialization file to be valid regardless of the system to which the user logs in. For example:

- To make a user's home directory available anywhere on the network, always refer to the home directory with the variable `$HOME`. For example, use `$HOME/bin` instead of `/export/home/username/bin`. `$HOME` works when the user logs in to another system and the home directories are automounted.
- To access files on a local disk, use global path names, like `/net/system-name/directory-name`. Any directory referenced by `/net/system-name` can be mounted automatically on any system on which the user logs in, assuming the

system is running AutoFS.

Shell Features

The following table lists basic shell features that each shell provides, which can help you determine what you can and can't do when creating user initialization files for each shell.

TABLE 4-18 Basic Features of Bourne, C, and Korn Shells

Feature	Bourne	C	Korn
Known as the standard shell in UNIX	Yes	No	No
Compatible syntax with Bourne shell	-	No	Yes
Job control	Yes	Yes	Yes
History list	No	Yes	Yes
Command-line editing	No	Yes	Yes
Aliases	No	Yes	Yes
Single-character abbreviation for login directory	No	Yes	Yes
Protection from overwriting (noclobber)	No	Yes	Yes
Setting to ignore Control-d (ignoreeof)	No	Yes	Yes
Enhanced cd	No	Yes	Yes
Initialization file separate from .profile	No	Yes	Yes
Logout file	No	Yes	No

Shell Environment

A shell maintains an environment that includes a set of variables defined by the `login` program, the system initialization file, and the user initialization files. In addition, some variables are defined by default. A shell can have two types of variables:

- Environment variables – Variables that are exported to all processes spawned by the shell. Their settings can be seen with the `env` command. A subset of environment variables, like `PATH`, affects the behavior of the shell itself.

- Shell (local) variables – Variables that affect only the current shell. In the C shell, a set of these shell variables have a special relationship to a corresponding set of environment variables. These shell variables are `user`, `term`, `home`, and `path`. The value of the environment variable counterpart is initially used to set the shell variable.

In the C shell, you use the lowercase names with the `set` command to set shell variables and use uppercase names with the `setenv` command to set environment variables. If you set a shell variable, the shell sets the corresponding environment variable and vice versa. For example, if you update the `path` shell variable with a new path, the shell also updates the `PATH` environment variable with the new path.

In the Bourne and Korn shells, you can use the uppercase variable name equal to some value to set both shell and environment variables. You also have to use the `export` command to activate the variables for any subsequently executed commands.

For all shells, you generally refer to shell and environment variables by their uppercase names.

In a user initialization file, you can customize a user's shell environment by changing the values of the predefined variables or by specifying additional variables. The following table shows how to set environment variables in a user initialization file.

TABLE 4–19 Setting Environment Variables in a User Initialization File

Set a User's Environment Variables for The Shell Type	Line to Add to the User Initialization File
C shell	<code>setenv VARIABLE value</code> Example: <code>setenv MAIL /var/mail/ripley</code>
Bourne or Korn shell	<code>VARIABLE=value; export VARIABLE</code> Example: <code>MAIL=/var/mail/ripley; export MAIL</code>

The following table describes environment and shell variables that you might want to customize in a user initialization file. For more information about variables that are used by the different shells, see `sh(1)`, `ksh(1)`, or `csh(1)`.

TABLE 4-20 Shell and Environment Variable Descriptions

Variable	Description
CDPATH, or <code>cdpath</code> in the C shell	Sets a variable used by the <code>cd</code> command. If the target directory of the <code>cd</code> command is specified as a relative path name, the <code>cd</code> command first looks for the target directory in the current directory (“.”). If the target is not found, the path names listed in the <code>CDPATH</code> variable are searched consecutively until the target directory is found and the directory change is completed. If the target directory is not found, the current working directory is left unmodified. For example, the <code>CDPATH</code> variable is set to <code>/home/jean</code> , and two directories exist under <code>/home/jean</code> , <code>bin</code> and <code>rje</code> . If you are in the <code>/home/jean/bin</code> directory and type <code>cd rje</code> , you change directories to <code>/home/jean/rje</code> , even though you do not specify a full path.
<code>history</code>	Sets history for the C shell.
HOME, or <code>home</code> in the C shell	Sets the path to the user’s home directory.
LANG	Sets the locale.
LOGNAME	Defines the name of the user currently logged in. The default value of <code>LOGNAME</code> is set automatically by the login program to the user name specified in the <code>passwd</code> file. You should only need to refer to, not reset, this variable.
LPDEST	Sets the user’s default printer.
MAIL	Sets the path to the user’s mailbox.
MANPATH	Sets the hierarchies of man pages available.
PATH, or <code>path</code> in the C shell	Specifies, in order, the directories that the shell searches to find the program to run when the user types a command. If the directory is not in the search path, users must type the complete path name of a command. The default <code>PATH</code> is automatically defined and set as specified in <code>.profile</code> (Bourne or Korn shell) or <code>.cshrc</code> (C shell) as part of the login process. The order of the search path is important. When identical commands exist in different locations, the first command found with that name is used. For example, suppose that <code>PATH</code> is defined in Bourne and Korn shell syntax as <code>PATH=/bin:/usr/bin:/usr/sbin:\$HOME/bin</code> and a file named <code>sample</code> resides in both <code>/usr/bin</code> and <code>/home/jean/bin</code> . If the user types the command <code>sample</code> without specifying its full path name, the version found in <code>/usr/bin</code> is used.
<code>prompt</code>	Defines the shell prompt for the C shell.
PS1	Defines the shell prompt for the Bourne or Korn shell.

TABLE 4-20 Shell and Environment Variable Descriptions (Continued)

Variable	Description
SHELL, or shell in the C shell	Sets the default shell used by <i>make</i> , <i>vi</i> , and other tools.
TERMINFO	<p>Specifies the path name for an unsupported terminal that has been added to the <code>terminfo</code> file. Use the <code>TERMINFO</code> variable in <code>/etc/profile</code> or <code>/etc/.login</code>.</p> <p>When the <code>TERMINFO</code> environment variable is set, the system first checks the <code>TERMINFO</code> path defined by the user. If it does not find a definition for a terminal in the <code>TERMINFO</code> directory defined by the user, it searches the default directory, <code>/usr/share/lib/terminfo</code>, for a definition. If the system does not find a definition in either location, the terminal is identified as “dumb.”</p>
TERM, or term in the C shell	Defines the terminal. This variable should be reset in <code>/etc/profile</code> or <code>/etc/.login</code> . When the user invokes an editor, the system looks for a file with the same name as the definition of this environment variable. The system searches the directory referenced by <code>TERMINFO</code> to determine the terminal characteristics.
TZ	Sets the time zone, which is used to display dates, for example, in the <code>ls -l</code> command. If <code>TZ</code> is not set in the user’s environment, the system setting is used. Otherwise, Greenwich Mean Time is used.

The PATH Variable

When the user executes a command by using the full path, the shell uses that path to find the command. However, when users specify only a command name, the shell searches the directories for the command in the order specified by the `PATH` variable. If the command is found in one of the directories, the shell executes the command.

A default path is set by the system, but most users modify it to add other command directories. Many user problems related to setting up the environment and accessing the right version of a command or a tool can be traced to incorrectly defined paths.

Setting Path Guidelines

Here are some guidelines for setting up efficient `PATH` variables:

- If security is not a concern, put the current working directory (`.`) first in the path. However, including the current working directory in the path poses a security risk that you might want to avoid, especially for superuser.
- Keep the search path as short as possible. The shell searches each directory in the path. If a command is not found, long searches can slow down system performance.

- The search path is read from left to right, so you should put directories for commonly used commands at the beginning of the path.
- Make sure directories are not duplicated in the path.
- Avoid searching large directories, if possible. Put large directories at the end of the path.
- Put local directories before NFS™ mounted directories to lessen the chance of “hanging” when the NFS server does not respond and to reduce unnecessary network traffic.

Examples—Setting a User’s Default Path

The following examples show how to set a user’s default path to include the home directory and other NFS mounted directories. The current working directory is specified first in the path. In a C-shell user initialization file, you would add the following:

```
set path=(. /usr/bin $HOME/bin /net/glrr/files1/bin)
```

In a Bourne- or Korn-shell user initialization file, you would add the following:

```
PATH=./usr/bin:/$HOME/bin:/net/glrr/files1/bin
export PATH
```

Locale Variables

The LANG and LC environment variables specify the locale-specific conversions and conventions for the shell, like time zones, collation orders, and formats of dates, time, currency, and numbers. In addition, you can use the stty command in a user initialization file to set whether the system will support multibyte characters.

LANG sets all possible conversions and conventions for the given locale. If you have special needs, you can set various aspects of localization separately through these LC variables: LC_COLLATE, LC_CTYPE, LC_MESSAGES, LC_NUMERIC, LC_MONETARY, and LC_TIME.

The following table describes some of the values for the LANG and LC environment variables.

TABLE 4–21 Values for LANG and LC Variables

Value	Locale
de	German
fr	French

TABLE 4-21 Values for LANG and LC Variables (Continued)

Value	Locale
iso_8859_1	English and European
it	Italian
japanese	Japanese
korean	Korean
sv	Swedish
tchinese	Taiwanese

Examples—Setting the Locale Using the LANG Variables

The following examples show how to set the locale by using the LANG environment variables. In a C-shell user initialization file, you would add the following:

```
setenv LANG DE
```

In a Bourne- or Korn-shell user initialization file, you would add the following:

```
LANG=DE; export LANG
```

Default File Permissions (umask)

When you create a file or directory, the default file permissions assigned to the file or directory are controlled by the *user mask*. The user mask is set by the `umask` command in a user initialization file. You can display the current value of the user mask by typing `umask` and pressing Return.

The user mask contains the following octal values:

- The first digit sets permissions for the user
- The second sets permissions for group
- The third sets permissions for other, also referred to as “world”

Note that if the first digit is zero, it is not displayed. For example, if `umask` is set to 022, 22 is displayed.

To determine the `umask` value you want to set, subtract the value of the permissions you want from 666 (for a file) or 777 (for a directory). The remainder is the value to use with the `umask` command. For example, suppose you want to change the default mode for files to 644 (`rw-r--r--`). The difference between 666 and 644 is 022, which is the value you would use as an argument to the `umask` command.

You can also determine the `umask` value you want to set by using the following table, which shows the file and directory permissions that are created for each of the octal values of `umask`.

TABLE 4-22 Permissions for umask Values

umask Octal Value	File Permissions	Directory Permissions
0	rw-	rwX
1	rw-	rw-
2	r--	r-X
3	r--	r--
4	-w-	-wX
5	-w-	-w-
6	--x	--X
7	--- (none)	--- (none)

The following line in a user initialization file sets the default file permissions to `rw-rw-rw-`.

```
umask 000
```

Examples of User and Site Initialization Files

The following sections provide examples of user and site initialization files that you can use to start customizing your own initialization files. Many of the examples use system names and paths that you need to change for your particular site.

Example—.profile File

```
1 PATH=$PATH:$HOME/bin:/usr/local/bin:/usr/ccs/bin:.  
2 MAIL=/var/mail/$LOGNAME  
3 NNTPSERVER=server1  
4 MANPATH=/usr/share/man:/usr/local/man  
5 PRINTER=printer1  
6 umask 022  
7 export PATH MAIL NNTPSERVER MANPATH PRINTER
```

1. Defines the user's shell search path.
2. Defines the path to the user's mail file.
3. Defines the user's Usenet news server.
4. Defines the user's search path for man pages.
5. Defines the user's default printer.
6. Sets the user's default file creation permissions.
7. Sets the listed environment variables.

Example—.cshrc File

```
1 set path=($PATH $HOME/bin /usr/local/bin /usr/ccs/bin)
2 setenv MAIL /var/mail/$LOGNAME
3 setenv NNTPSERVER server1
4 setenv PRINTER printer1
5 alias h history
6 umask 022
7 source /net/server2/site-init-files/site.login
```

1. Defines the user's shell search path.
2. Defines the path to the user's mail file.
3. Defines the user's Usenet news server.
4. Defines the user's default printer.
5. Creates an alias for the `history` command. The user will need to type only `h` to run the `history` command.
6. Sets the user's default file creation permissions.
7. Sources the site initialization file.

Example—Site Initialization File

The following shows an example site initialization file in which a user can choose a particular version of an application.

```
# @(#)site.login
main:
echo "Application Environment Selection"
echo ""
echo "1. Application, Version 1"
echo "2. Application, Version 2"
echo ""
echo -n "Type 1 or 2 and press Return to set your
application environment: "

set choice = <

if ( $choice !~ [1-2] ) then
goto main
endif

switch ($choice)

case "1":
setenv APPHOME /opt/app-v.1
breaksw

case "2":
setenv APPHOME /opt/app-v.2
endsw
```

This site initialization file could be referenced in a user's `.cshrc` file (C shell users only) with the following line:

```
source /net/server2/site-init-files/site.login
```

In this line, the site initialization file is named `site.login` and is located on a server named `server2`. This line also assumes that the automounter is running on the user's system.

Managing User Accounts and Groups (Tasks)

This chapter describes how to set up and maintain user accounts and groups by using the Solaris Management Console.

For information on the procedures associated with setting up and maintaining user accounts and groups with the Solaris Management Console, see “Setting Up User Accounts (Task Map)” on page 101 and “Maintaining User Accounts (Task Map)” on page 110.

For background information about managing user accounts and groups, see Chapter 4.

Setting Up User Accounts (Task Map)

Task	Description	For Instructions
(Optional) Gather user information	Use a standard form to gather user information to help you keep user information organized.	“How to Gather User Information” on page 102
(Optional) Customize user initialization files	You can set up user initialization files (<code>.cshrc</code> , <code>.profile</code> , <code>.login</code>), so you can provide new users with consistent environments.	“How to Customize User Initialization Files” on page 103
(Optional) Add a group	You can add a group with the following tools:	

Task	Description	For Instructions
	Solaris Management Console's Groups tool	"How to Add a Group with the Solaris Management Console's Groups Tool" on page 105
	Solaris command line interface tools	"How to Add Groups and Users With CLI Tools" on page 107
Add a user	You can add a user with the following tools:	
	Solaris Management Console's Users Tool	"How to Add a User With the Solaris Management Console's Users Tool" on page 106
	Solaris command line interface tools	"How to Add Groups and Users With CLI Tools" on page 107
(Optional) Set up a user template	You can create a user template so you don't have to manually add all similar user properties.	See Solaris Management Console online help
(Optional) Add rights or a role to a user	You can add rights or a role to a user so the user can perform a specific command or task.	See Solaris Management Console online help
Share the user's home directory	You must share the user's home directory so the directory can be remotely mounted from the user's system.	"How to Share a User's Home Directory" on page 107
Mount the user's home directory	You must mount the user's home directory on the user's system.	"How to Mount a User's Home Directory" on page 109

How to Gather User Information

You can create a form like the one that follows to gather information about users before adding their accounts.

Item	Description
User Name:	

Role Name:	
Profiles or Authorizations:	
User Name:	
UID:	
Primary Group:	
Secondary Groups:	
Comment:	
Default Shell:	
Password Status and Aging:	
Home Directory Server Name:	
Home Directory Path Name:	
Mounting Method:	
Permissions on Home Directory:	
Mail Server:	
Department Name:	
Department Administrator:	
Manager:	
Employee Name:	
Employee Title:	
Employee Status:	
Employee Number:	
Start Date:	
Add to These Mail Aliases:	
Desktop System Name:	

▼ How to Customize User Initialization Files

1. Become superuser or assume an equivalent role on the system where the users' home directories are created and shared.
2. Create a skeleton directory for each type of user.

```
# mkdir /shared-dir/skel/user-type
```

<i>shared-dir</i>	The name of a directory that is available to other systems on the network.
<i>user-type</i>	The name of a directory to store initialization files for a type of user.

3. Copy the default user initialization files into the directories you created for different types of users.

```
# cp /etc/skel/local.cshrc /shared-dir/skel/user-type/.cshrc
# cp /etc/skel/local.login /shared-dir/skel/user-type/.login
# cp /etc/skel/local.profile /shared-dir/skel/user-type/.profile
```

Note – If the account has profiles assigned to it, then the user has to launch a special version of the shell called a profile shell to use commands (with any security attributes) that are assigned to the profile. There are three profile shells corresponding to the types of shells: `pfsh` (Bourne shell), `pfcsh` (C shell), and `pfksh` (Korn shell).

4. Edit the user initialization files for each user type and customize them based on your site’s needs.

For a detailed description on the ways to customize the user initialization files, see “Customizing a User’s Work Environment” on page 88.

5. Set the permissions for the user initialization files.

```
# chmod 744 /shared-dir/skel/user-type/.*
```

6. Verify that the permissions for the user initialization files are correct.

```
# ls -la /shared-dir/skel/*
```

Example—Customizing User Initialization Files

The following example shows how to customize the C-shell user initialization file in the `/export/skel/enduser` directory designated for a particular type of user. For an example of a `.cshrc` file, see “Example—.cshrc File” on page 98.

```
# mkdir /export/skel/enduser
# cp /etc/skel/local.cshrc /export/skel/enduser/.cshrc
```

(*Edit .cshrc file*)

```
# chmod 744 /export/skel/enduser/.*
```

▼ How to Add a Group with the Solaris Management Console's Groups Tool

Use this procedure to add a group to the system.

1. **Become superuser or assume an equivalent role.**
2. **Start the Solaris Management Console.**

```
# /usr/sadm/bin/smc &
```

For more information on starting the Solaris Management Console, see “How to Start the Console as Superuser or as a Role” on page 54 or “How to Start the Solaris Management Console in a Name Service Environment” on page 61.

3. **Double-click the This Computer icon under the Management Tools icon in the Navigation pane.**
A list of categories is displayed.
4. **(Optional) Select the appropriate toolbox for your name service environment.**
5. **Double-click the System Configuration icon.**
6. **Double-click the User Accounts icon.**
7. **Provide the superuser password or the role password.**
8. **Double-click the Groups icon.**
Use the Context help to add a group to the system.

Example—Adding a Group With the Solaris Management Console's Groups Tool

The following example identifies the steps to add the group `mechanoids` (group ID 101) to the system `starbug`. This example assumes that the launcher has been started and Users tool is open.

You can add existing users to the group when you add the group. Or, you can just add the group and then add the user to the group when you add the user.

- Select Add Group from the Action menu.
- Identify the group name, `mechanoids`, at the Group Name prompt under Group Identification.
- Identify the group number, `101`, at the Group ID number prompt.
- Click on OK.

▼ How to Add a User With the Solaris Management Console's Users Tool

Use the following procedure to add a user to the system.

1. **Become superuser or assume an equivalent role.**

2. **Start the Solaris Management Console.**

```
# /usr/sadm/bin/smc &
```

For more information on starting the Solaris Management Console, see “How to Start the Console as Superuser or as a Role” on page 54 or “How to Start the Solaris Management Console in a Name Service Environment” on page 61.

3. **Double-click the This Computer icon under the Management Tools icon in the Navigation pane.**

A list of categories is displayed.

4. **(Optional) Select the appropriate toolbox for your name service environment.**

5. **Double-click the System Configuration icon.**

6. **Double-click the User Accounts icon.**

7. **Provide the superuser password or the role password.**

8. **Double-click the Users icon.**

Use the Context help to add a user to the system.

Example—Adding a User With the Solaris Management Console's Groups Tool

The following example identifies the steps to add the user `kryten` (user ID 1001) to the system `starbug`. This example assumes that the launcher has been started and Users Tool is open.

Click Next between the steps below.

- Select Add User—>With Wizard from the Action menu.
- Step 1 – Identify the user's name or login name, `kryten`, at the User Name prompt under Group Identification.
- (Optional) Identify the user's full name, `kryten series 3000`, at the Full Name prompt.
- (Optional) Provide a further description of this user at the Description prompt.
- Step 2 – Provide the user ID, 1001, at the User ID Number prompt.
- Step 3 – Select the User Must Use This Password At First Login option.

Provide a password for the user at the Password prompt and then confirm the password at the Confirm Password prompt.

- Step 4 – Select the user’s primary group, `mechanoids`.
- Step 5 – Create the user’s home directory by accepting the defaults at the Server and Path prompts.
- Step 6 – Specify the mail server.
- Step 7 – Review the information you provided and go back to correct the information, if necessary. Otherwise, click on Finish.

How to Add Groups and Users With CLI Tools

This section provides examples of adding users and groups with CLI tools.

Example—Adding a Group and User With the `groupadd` and `useradd` Commands

The following example shows how to use the `groupadd` and `useradd` commands to add the group `scutters` and user `scutter1` to files on the local system. These commands cannot be used to manage users in a name service environment.

```
# groupadd -g 102 scutters
# useradd -u 1003 -g 102 -d /export/home/scutter1 -s /bin/csh -c "Scutter 1"
-m -k /etc/skel scutter1
64 blocks
```

For more information, see `groupadd(1M)` and `useradd(1M)`.

Example—Adding a Group and User With the `smgroup` and `smuser` Commands

The following example shows how to use the `smgroup` and `smuser` commands to add the group `gelfs` and the user `camille` to the NIS domain `solar.com` on the host `starbug`.

```
# /usr/sadm/bin/smgroup add -D nis:/starbug/solar.com -- -g 103 -n gelfs
# /usr/sadm/bin/smuser add -D nis:/starbug/solar.com -- -u 1004 -n camille
-c "Camille G." -d /export/home/camille -s /bin/csh -g gelfs
```

For more information, see `smgroup(1M)` and `smuser(1M)`.

▼ How to Share a User’s Home Directory

1. Become superuser or assume an equivalent role on the system that contains the home directory.

2. Verify that the mountd daemon is running.

```
# ps -ef | grep mountd
root  176      1  0   May 02 ?          0:19 /usr/lib/nfs/mountd
```

The `/usr/lib/nfs/mountd` line shows whether the `mountd` daemon is running.

3. If the mountd daemon is not running, start it.

```
# /etc/init.d/nfs.server start
```

4. List the file systems that are shared on the system.

```
# share
```

5. Select one of the following based on whether the file system containing the user's home directory is already shared.

a. If the user's home directory is already shared, go to the verification step below.

b. If the user's home directory is not shared, go to Step 6.

6. Edit the `/etc/dfs/dfstab` file and add the following line.

```
share -F nfs /file-system
```

file-system is the file system containing the user's home directory that you need to share. By convention, the file system is `/export/home`.

7. Share the file systems listed in the `/etc/dfs/dfstab` file.

```
# shareall -F nfs
```

This command executes all the `share` commands in the `/etc/dfs/dfstab` file, so you do not have to wait to reboot the system.

8. Verify that a user's home directory is shared, as follows:

```
# share
```

Where to Go From Here

If the user's home directory is not located on the user's system, you have to mount the user's home directory from the system where it is located. For detailed instructions, see "How to Mount a User's Home Directory" on page 109.

Example—Sharing a User's Home Directory

```
# ps -ef | grep mountd
# /etc/init.d/nfs.server start
# share
# vi /etc/dfs/dfstab
```

```
(The line share -F nfs /export/home is added.)
# shareall -F nfs
# share
-                /usr/dist                ro    ""
-                /export/home/user-name    rw    ""
```

▼ How to Mount a User's Home Directory

For information on automounting a home directory, see “Task Overview for Autofs Administration” in *System Administration Guide: Resource Management and Network Services*.

1. Make sure that the user's home directory is shared.

For more information, see “How to Share a User's Home Directory” on page 107.

2. Log in as superuser on the user's system.

3. Edit the `/etc/vfstab` file and create an entry for the user's home directory.

```
system-name:/export/home/user-name - /export/home/user-name nfs - yes rw
```

<code>system-name</code>	The name of the system where the home directory is located.
<code>/export/home/user-name</code>	The name of the user's home directory that will be shared. By convention, <code>/export/homeuser-name</code> contains user's home directories. However, this could be a different file system.
-	Required placeholders in the entry.
<code>/export/home/user-name</code>	The name of the directory where the user's home directory will be mounted.

For more information about adding an entry to the `/etc/vfstab` file, see Chapter 40.

4. Create the mount point for the user's home directory.

```
# mkdir -p /export/home/user-name
```

5. Mount the user's home directory.

```
# mountall
```

All entries in the current `vfstab` file (whose `mount at boot` fields are set to `yes`) are mounted.

6. Verify that the home directory is mounted.

```
# mount | grep user-name
```

Example—Mounting a User’s Home Directory

```
# vi /etc/vfstab

(The line venus:/export/home/ripley - /export/home/ripley
nfs - yes rw is added.)
# mkdir -p /export/home/ripley
# mountall
# mount
/ on /dev/dsk/c0t0d0s0 read/write/setuid/intr/largefiles/xattr/onerror=panic/dev=...
/usr on /dev/dsk/c0t0d0s6 read/write/setuid/intr/largefiles/xattr/onerror=panic/dev=...
/proc on /proc read/write/setuid/dev=38c0000 on Sun Feb  2 18:20:07 2003
/etc/mnttab on mnttab read/write/setuid/dev=3980000 on Sun Feb  2 18:20:07 2003
/dev/fd on fd read/write/setuid/dev=39c0000 on Sun Feb  2 18:20:10 2003
/var/run on swap read/write/setuid/xattr/dev=1 on Sun Feb  2 18:20:11 2003
/tmp on swap read/write/setuid/xattr/dev=2 on Sun Feb  2 18:20:15 2003
/export/home on /dev/dsk/c0t0d0s7 read/write/setuid/intr/largefiles/xattr/onerror=...
/export/home/ripley on venus:/export/home/ripley remote/read/write/setuid/xattr/dev=...
```

Maintaining User Accounts (Task Map)

Task	Description	Instructions
Modify a Group	You can modify a group’s name or the users in a group by using the Groups Tool.	See Solaris Management Console online help
Delete a Group	You can delete a group if its no longer needed.	See Solaris Management Console online help
Modify a User Account	<i>Disable a User Account</i> You can temporarily disable a user account if it will be needed in the future. <i>Change a User’s Password</i> You might need to change a user’s password if the user forgets it.	See Solaris Management Console online help See Solaris Management Console online help

Task	Description	Instructions
	<p><i>Change Password Aging</i></p> <p>You can force users to change their passwords periodically with User Account tool's Password Options menu.</p>	See Solaris Management Console online help
Delete a User Account	You can delete a user account if it is no longer needed.	See Solaris Management Console online help

Solaris User Registration

Solaris User Registration is a tool for getting information about new Solaris releases, upgrade offers, and promotions. This graphical user interface (GUI) automatically starts when you first log into your desktop. The GUI lets you register now, later, or never. The registration process also provides Sun with the user's Solaris version, survey type, platform, hardware, and locale.

Accessing Solaris Solve

Completing the Solaris User Registration process provides access to Solaris SolveSM, an exclusive web site that offers valuable Solaris product information and solutions—all in one convenient location. It provides a quick and easy method for getting the most recent information on what's happening around the latest Solaris release. Solaris Solve also provides a preview to additional Sun contract and service opportunities.

Basically, the steps for completing Solaris User Registration and accessing Solaris Solve are:

1. Fill in the electronic Solaris User Registration profile.
2. Submit the profile by email or print the profile to fax or mail.
3. Create your login ID and password to access the Solaris Solve site.

Even if you do not access the Solaris Solve site immediately, we recommend that you create your Solaris Solve login ID and password during the Solaris User Registration process. A Solaris Solve login ID and password should contain 6 to 8 alphanumeric characters without spaces and colons.

4. Access the Solaris Solve site.

Note – Solaris User Registration is not invoked if the system administrator or user is logged in as superuser.

If you choose to register, a copy of the completed form is stored in `$HOME/.solregis/uprops`. If you choose to never register and change your mind later, you can start User Registration by:

- Typing `/usr/dt/bin/solregis` at any command line prompt, or
- Clicking the Registration icon in the Application Manager's desktop tools folder (Common Desktop Environment desktop only)

For more information, see `solregis(1)`.

Troubleshooting Solaris User Registration Problems

This section provides troubleshooting tips for solving Solaris User Registration problems.

The following table describes problems that may occur when you try to register, and actions required to resolve these conflicts.

TABLE 5-1 Registration Problem Descriptions and Suggested Resolutions

Problem Description	How to Resolve the Problem
The registration form failed to initialize: Web page window displays and requests user see system administrator to resolve problem that prevents registration setup.	Check for missing registration files.
The form could not be emailed: Dialog box displays and requests user see system administrator to resolve problem.	Check to see if email is configured correctly. Also check if CDE is on user's system since it must be present to email completed registration form. Alternatively, users can print the form and fax or mail it.
The form could not be printed: Dialog box displays and requests user to see system administrator to resolve problem.	Check to see if the printer is configured correctly. Alternatively, the user can email form.

TABLE 5-1 Registration Problem Descriptions and Suggested Resolutions (Continued)

Problem Description	How to Resolve the Problem
The form could not be saved: Dialog box displays and verifies that registration succeeded; however, the registration information cannot be recalled when updating registration in the future.	Check the user's home directory. Required action depends on the system's configuration.
You forgot your Solaris Solve login ID and password.	Send a mail message describing the problem to <code>SolarisSolve@sun.com</code> or see "How to Restart Solaris User Registration" on page 113.
You want to restart the registration process.	"How to Restart Solaris User Registration" on page 113.

▼ How to Restart Solaris User Registration

Use the following procedure to restart the Solaris User Registration process.

1. **Change to the `$HOME/.solregis` directory.**

```
% cd $HOME/.solregis
```

2. **Remove the `uprops` file.**

```
% rm uprops
```

3. **Restart the registration process.**

```
% /usr/dt/bin/solregis &
```

▼ How To Disable User Registration

You can disable User Registration before or after installing Solaris software. Before disabling Solaris User Registration, Sun recommends that system administrators register for their organization.

1. **To disable user registration before installing the Solaris release, select one of the following:**

- Deselect the `SUNWSregu` package (interactive installation).
- Modify a custom JumpStart profile to not install the `SUNWSregu` package.
- Create and run a finish script that creates a file named `solregis` in the `/etc/default` directory on one or more systems with the following line in the script:

```
DISABLE=1
```

For more information see *Solaris 9 12/03 Installation Guide* or `solregis(1)`.

2. **To disable user registration after installing the Solaris release, select one of the following:**
 - Remove the `SUNWsregu` package
 - Add the `solregis` file to the `/etc/default` directory.

Managing Server and Client Support Topics

This topic map lists the chapters that provide information on managing server and client support.

Chapter 7	Provides a high-level overview about managing server and client support on a network. This chapter describes the different system types for which you can add support, and guidelines for choosing a system type for your environment.
Chapter 8	Provides step-by-step instructions for managing diskless client support with the <code>smservice</code> and <code>smdiskless</code> commands.

Managing Server and Client Support (Overview)

This chapter describes the management of server and client support on a network, and it provides overview information about each system configuration (referred to as a *system type*) that is supported in the Solaris environment. This chapter also includes guidelines for selecting the appropriate system type to meet your needs.

This is a list of the overview information in this chapter.

- “What’s New in Server and Client Management?” on page 117
- “Where to Find Server and Client Tasks” on page 118
- “What Are Servers, Clients, and Appliances?” on page 118
- “What Does Client Support Mean?” on page 119
- “Overview of System Types” on page 120
- “Diskless Client Management Overview” on page 123

For step-by-step instructions about how to manage diskless client support, see Chapter 8.

What’s New in Server and Client Management?

This section describes new server and client management features in the Solaris 9 release.

Diskless Client Support

In this Solaris release, you can manage diskless clients with the `smoservice` and `smdiskless` commands. Diskless clients are systems with no disks that depend on servers for all their services.

These commands are part of the Solaris Management Console tool suite. You cannot use the Solaris Management Console to manage diskless clients. You can only use the `smosservice` and `smdiskless` commands to manage diskless clients.

For more information on managing diskless clients, see “Diskless Client Management Overview” on page 123 and Chapter 8.

Where to Find Server and Client Tasks

Use this table to find step-by-step instructions for setting up server and client support.

Server/Client Services	For More Information
Install or JumpStart clients	<i>Solaris 9 12/03 Installation Guide</i>
Diskless client systems in the Solaris 9 environment	“Diskless Client Management Overview” on page 123 and Chapter 8
Diskless client systems and Solstice AutoClient systems in previous Solaris releases	<i>Solstice AdminSuite 2.3 Administration Guide</i>
AutoClient 3.0.1 systems in the Solaris 8 or Solaris 9 environments	Call your service provider

What Are Servers, Clients, and Appliances?

Systems on the network can usually be described as one of the following:

System Type	Description
Server	A system that provides services to other systems in its network. There are file servers, boot servers, web servers, database servers, license servers, print servers, installation servers, appliance servers, and even servers for particular applications. This chapter uses the term server to mean a system that provides boot services and file systems for other systems on the network.

System Type	Description
Client	<p>A system that uses remote services from a server. Some clients have limited disk storage capacity, or perhaps none at all, and they have to rely on remote file systems from a server to function. Diskless systems, AutoClient systems, and appliance systems are examples of this type of client.</p> <p>Other clients might use remote services (such as installation software) from a server, but they don't rely on a server to function. A standalone system, which has its own hard disk containing the root (/), /usr, and /export/home file systems and swap space, is a good example of this type of client.</p>
Sun Cobalt Server Appliance	<p>The Sun Cobalt server appliance provides an integrated set of pre-configured Internet services. Users of the server appliance just need a web browser and an IP address. Administration on the servers is centralized and the appliance users require no client administration. For more information, see http://www.sun.com/hardware/serverappliances.</p>
Appliance	<p>A network appliance such as the Sun Ray appliance provides access to applications and the Solaris environment. An appliance gives you centralized server administration and no client administration or upgrades. Sun Ray appliances also provide <i>hot desking</i>, which is the ability to instantly access your computing session from any appliance in the server group, exactly where you left off. For more information, see http://www.sun.com/products/sunray.</p>

What Does Client Support Mean?

Support for a client means providing software and services to help the client function. Support can include the following:

- Making a system known to the network (host name and Ethernet address information)
- Providing installation services to remotely boot and install a system
- Providing operating system (OS) services and application services to a system with limited disk space or no disk space

Overview of System Types

System types are sometimes defined by how they access the root (/) and /usr file systems, including the swap area. For example, standalone systems and server systems mount these file systems from a local disk, while other clients mount the file systems remotely, relying on servers to provide these services. This table lists some of the characteristics of each system type.

TABLE 7-1 Characteristics of General System Types

System Type	Local File Systems	Local Swap?	Remote File Systems	Network Use	Relative Performance
Server	root (/) /usr /home /opt /export/home /export/root	Yes	– None –	High	High
Standalone System	root (/) /usr /export/home	Yes	– None –	Low	High
Diskless Client	– None –	No	root (/) swap /usr /home	High	Low
AutoClient System	Cached root (/) Cached /usr	Yes	/var	Low	High
Appliance	None	None	None	High	High

Servers

A server system contains the following file systems:

- The root (/) and /usr file systems, plus swap space
- The /export and /export/home file systems, which support client systems and provide home directories for users

- The `/opt` directory or file system for storing application software

Servers can also contain the following software to support other systems:

- Operating system (OS) services for diskless systems or AutoClient systems that are running a different release or clients that are a different platform than the server
- Solaris CD image software and boot software for networked systems to perform remote installations
- JumpStart™ directory for networked systems to perform custom JumpStart installations

Standalone Systems

A *networked standalone system* can share information with other systems in the network, but it can continue to function if detached from the network.

A standalone system can function autonomously because it has its own hard disk that contains the root (`/`), `/usr`, and `/export/home` file systems and swap space. The standalone system thus has local access to operating system software, executables, virtual memory space, and user-created files.

Note – A standalone system requires sufficient disk space to hold its necessary file systems.

A *non-networked standalone system* is a standalone system with all the characteristics listed above, except it is not connected to a network.

Diskless Clients

A *diskless client* has no disk and depends on a server for all its software and storage needs. A diskless client remotely mounts its root (`/`), `/usr`, and `/home` file systems from a server.

A diskless client generates significant network traffic due to its continual need to procure operating system software and virtual memory space from across the network. A diskless client cannot operate if it is detached from the network or if its server malfunctions.

For more overview information about diskless clients, see “Diskless Client Management Overview” on page 123.

AutoClient Systems

An AutoClient system is nearly identical to a diskless client in terms of installation and administration. An AutoClient system has the following characteristics:

- Requires a minimum of a 100-Mbyte local disk for swapping and for caching its individual root (/) file system and the /usr file system from a server
- Can be set up so that it continues to access its cache when the server is unavailable
- Relies on a server to access other file systems and software applications
- Contains no permanent data, making it a field-replaceable unit (FRU)

Appliances

An appliance, such as the Sun Ray appliance, is an X display device that requires no administration. There is no CPU, fan, disk, and very little memory. An appliance is connected to a Sun display monitor, but the appliance user's desktop session is run on a server and displayed back to the user. The X environment is setup automatically for the user and has the following characteristics:

- Relies on a server to access other file systems and software applications
- Provides centralized software administration and resource sharing
- Contains no permanent data, making it a field-replaceable unit (FRU)

Guidelines for Choosing System Types

You can determine which system types are appropriate for your environment by comparing each system type based on the following characteristics:

- Centralized Administration
 - Can the system be treated as a field-replaceable unit (FRU)? This means that a broken system can be quickly replaced with a new system without any lengthy backup and restore operations and no loss of system data.
 - Does the system need to be backed up? Large costs in terms of time and resources can be associated with backing up a large number of desktop systems.
 - Can the system's data be modified from a central server?
 - Can the system be installed from a centralized server, quickly and easily, without handling the client system's hardware?
- Performance
 - Does this configuration perform well in desktop usage?
 - Does the addition of systems on a network affect the performance of other systems already on the network?
- Disk Space Usage

- How much disk space is required to effectively deploy this configuration?

This table describes how each system type scores in terms of each category. A ranking of 1 is most efficient. A ranking of 4 is least efficient.

TABLE 7-2 Comparison of System Types

System Type	Centralized Administration	Performance	Disk Usage
Standalone System	4	1	4
Diskless Client	1	4	1
AutoClient System	1	2	2
Appliance	1	1	1

Diskless Client Management Overview

The following sections and Chapter 8 describe how to manage diskless client support in the Solaris 9 release.

A *diskless client* is a system that depends on an *OS server* for its operating system, software, and storage. A diskless client mounts its root (*/*), */usr*, and other file systems from its OS server. A diskless client has its own CPU and physical memory and can process data locally. However, a diskless client cannot operate if it is detached from its network or if its OS server malfunctions. A diskless client generates significant network traffic because of its continual need to function across the network.

In previous Solaris releases, diskless clients were managed with the Solstice graphical management tools. In the Solaris 9 release, the diskless client commands, *smosservice* and *smdiskless*, enable you to manage OS services and diskless client support.

OS Server and Diskless Client Support Information

The following table describes which Solaris releases and architecture types are supported by the `smosservice` and `smdiskless` commands.

Architecture Type	Solaris 2.6	Solaris 7	Solaris 8 1/01, 4/01, 7/01, 10/01, 2/02	Solaris 9
SPARC Servers	Supported	Supported	Supported	Supported
x86 Servers	Supported	Supported	Supported	Supported
SPARC Clients	Supported	Supported	Supported	Supported
x86 Clients	Not Supported	Not Supported	Not Supported	Supported

This table describes the combination of OS server-client configurations that are supported by the `smosservice` and `smdiskless` commands.

	Solaris 2.6 Release Support	Solaris 7 Release Support	Solaris 8 1/01, 4/01, 7/01, 10/01, 2/02 Support	Solaris 9 Support
OS Server-Client OS Release	Solaris 2.6–Solaris 2.6	Solaris 7–Solaris 2.6, or 7	Solaris 8 1/01, 4/01, 7/01, 10/01, 2/02–Solaris 2.6, 7, or 8 1/01, 4/01, 7/01, 10/01, 2/02	Solaris 9–Solaris 2.6, 7, 8 1/01, 4/01, 7/01, 10/01, 2/02

Diskless Client Management Features

You can use the `smosservice` and `smdiskless` commands to add and maintain diskless client support on a network. By using a name service, you can manage system information in a centralized manner so that important system information, such as host names, does not have to be duplicated on every system in the network.

You can do the following tasks with the `smosservice` and `smdiskless` commands:

- Add and modify diskless client support
- Add and remove OS services
- Manage diskless client information in the LDAP, NIS, NIS+, or files environment

You can only use the diskless client commands to set up diskless client booting. You cannot use them to set up other services, such as remote installation or profile services. Set up remote installation services by including diskless client specifications in the `sysidcfg` file. For more information, see *Solaris 9 12/03 Installation Guide*.

Working With Diskless Client Commands

By writing your own shell scripts and using the commands shown in the following table, you can easily set up and manage your diskless client environment.

TABLE 7-3 Diskless Client Commands

Command	Subcommand	Task
<code>/usr/sadm/bin/smosservice</code>	<code>add</code>	Add OS services
	<code>delete</code>	Delete OS services
	<code>list</code>	List OS services
	<code>patch</code>	Manage OS service patches
<code>/usr/sadm/bin/smdiskless</code>	<code>add</code>	Add a diskless client to an OS server
	<code>delete</code>	Delete a diskless client from an OS server
	<code>list</code>	List the diskless clients on an OS server
	<code>modify</code>	Modify the attributes of a diskless client

You can obtain help on these commands in two ways:

- Use the `-h` option when you type the command, subcommand, and required options. For example, to display the usage statement for `smdiskless add` type the following:

```
% /usr/sadm/bin/smdiskless add -p my-password -u my-user-name -- -h
```
- View the `smdiskless(1M)` or `smosservice(1M)` man pages.

Required RBAC Rights for Diskless Client Management

You can use the `smoservice` and `smdiskless` commands as superuser. If you are using Role-Based Access Control (RBAC), you can use either a subset or all of the diskless client commands, according to the RBAC rights to which they are assigned. The following table lists the RBAC rights that are required to use the diskless client commands.

TABLE 7-4 Required Rights For Diskless Client Management

RBAC Right	Command	Task
Basic Solaris User, Network Management	<code>smoservice list</code>	List OS services
	<code>smoservice patch</code>	List OS services patches
	<code>smdiskless list</code>	List diskless clients
Network Management	<code>smdiskless add</code>	Add diskless clients
System Administrator	All commands	All tasks

Adding OS Services

A Solaris OS server is a server that provides operating system (OS) services to support diskless client systems. You can add support for an OS server or convert a standalone system to an OS server with the `smoservice` command.

For each platform group and Solaris release that you want to support, you must add the particular OS service to the OS server. For example, if you want to support SPARC[®] Sun4m systems running the Solaris 8 release, you must add Sun4m/Solaris 8 OS services to the OS server. You would also still need to add OS services to support SPARC Sun4c systems or x86 based systems that runs the Solaris 8 release, because they are different platform groups.

You must have access to the appropriate Solaris CD or disk image to add OS services.

Adding OS Services When the OS Server Has Been Patched

When adding OS services to an OS server, you might see error messages saying that you have inconsistent versions of the OS running on the server and the OS that you are trying to add. This message occurs when the installed version of the OS has packages that were previously patched and the OS services being added do not have those packages patched (because the patches have been integrated into the packages).

For example, you may have a server that is running the Solaris 7 release. You may also have additional OS services loaded on this server, including the Solaris 2.6 SPARC sun4m OS services that have been patched. If you try to add the Solaris 2.6 SPARC sun4c OS services from a CD-ROM to this server, you could get the following error message:

```
Error: inconsistent revision, installed package appears to have been
patched resulting in it being different than the package on your media.
You will need to backout all patches that patch this package before
retrying the add OS service option.
```

Disk Space Requirements for OS Servers

Before you set up your diskless client environment, make sure you have the required disk space available for each diskless client directory.

In previous Solaris releases, you were prompted about diskless client support during the installation process. In the Solaris 9 release, you must manually allocate an `/export` file system either during installation or create it after installation. See the following table for specific disk space requirements.

TABLE 7-5 Disk Space Requirements for OS Servers

Directory	Required Space in Mbytes
<code>/export/Solaris_version</code>	10
<code>/export/exec</code>	800
<code>/export/share</code>	5
<code>/export/swap/diskless_client</code>	32 (default size)
<code>/export/dump/diskless_client</code>	32 (default size)
<code>/export/root/templates/Solaris_version</code>	30
<code>/export/root/clone/Solaris_version/ machine_class</code>	30 through 60 (depends on machine class)
<code>/export/root/diskless_client</code> (clone of above)	30 through 60 (depends on machine class)
<code>/tftpboot/inetboot.machine_class.Solaris_ version</code>	200 Kbytes per <code>machine_class.Solaris_version</code>

Managing Diskless Clients (Tasks)

This chapter describes how to manage diskless clients in the Solaris environment.

For information on the procedures associated with managing diskless clients, see “Managing Diskless Clients (Task Map)” on page 129.

For overview information on managing diskless clients, see Chapter 7.

For information about managing clients with Solstice AdminSuite™ software, see *Solstice AdminSuite 2.3 Administration Guide*.

Managing Diskless Clients (Task Map)

The following table identifies the procedures needed to manage diskless clients.

Task	Description	For Instructions
1. (Optional) Remove existing diskless client support	If you have existing diskless clients that were added with the Solstice AdminSuite product, remove the diskless client support and OS services with the <code>admhostdel</code> and <code>admhostmod</code> commands before installing the Solaris release.	<i>Solstice AdminSuite 2.3 Administration Guide</i>

Task	Description	For Instructions
3. (Optional) Enable Solaris Management Console logging to view diskless client error messages	Choose Log Viewer from the console main window to view diskless client error messages.	"Starting the Solaris Management Console" on page 54
4. Prepare for adding a diskless client	Verify supported releases and identify the <i>platform</i> , <i>mediapath</i> , and <i>cluster</i> (or software group) of each diskless client.	"How to Prepare for Adding Diskless Clients" on page 132
5. Add required OS services to an OS server	Add the OS services for the diskless clients you want to support with the <code>smoservice</code> command. You must identify the platform, media path, and each diskless client platform that you want to support.	"How to Add OS Services For Diskless Client Support" on page 133
6. Add a diskless client	Add diskless client support by specifying all required information with the <code>smdiskless</code> command.	"How to Add a Diskless Client" on page 135
7. Boot the diskless client	Verify that the diskless client support is successfully added by booting the diskless client.	"How to Boot a Diskless Client" on page 136
8. (Optional) Delete diskless client support	Delete support for a diskless client if it is no longer required.	"How to Delete Diskless Client Support" on page 137
9. (Optional) Delete OS services for a diskless client	Delete OS services for a diskless client if they are no longer needed.	"How to Delete OS Services for Diskless Clients" on page 137
10. (Optional) Patch OS services	Add, delete, list, or synchronize patches for diskless client OS services.	"How to Add an OS Patch for a Diskless Client" on page 139

Managing Diskless Clients

These sections describe the procedures needed to manage diskless clients.

Keep the following key points in mind when managing diskless clients:

- The Solaris installation program doesn't prompt you to set up diskless client support. You must manually create an `/export` partition to support diskless clients. You create the `/export` partition during or after the installation process.
- The `/export` partition must contain a minimum of 800–1000 Mbytes, depending upon the number of clients supported. For specific information, see "Disk Space Requirements for OS Servers" on page 127.
- The name service identified in the `smosservice` or `smdiskless` commands must match the primary name service identified in the `/etc/nsswitch.conf` file. If you don't specify a name service in the `smdiskless` or `smosservice` commands, the default name service is `files`.

After you determine the platform, media path, and cluster for each diskless client, you are ready to add OS services. The following directories are created and populated for each OS service that you add:

- `/export/Solaris_version/Solaris_version_instruction_set.all` (symbolic link to `/export/exec/Solaris_version/Solaris_version_instruction_set.all`)
- `/export/Solaris_version`
- `/export/Solaris_version/var`
- `/export/Solaris_version/opt`
- `/export/share`
- `/export/root/templates/Solaris_version`
- `/export/root/clone`
- `/export/root/clone/Solaris_version`
- `/export/root/clone/Solaris_version/machine_class`

The following default directories are created and populated on the OS server for each diskless client that you add:

- `/export/root/diskless_client`
- `/export/swap/diskless_client`
- `/tftpboot/diskless_client_ipaddress_in_hex/export/dump/diskless_client` (if you specify the `-x dump` option)

Note – You can modify the default locations of the `root`, `/swap`, and `/dump` directories by using the `-x` option. However, do not create these directories under the `/export` file system.

▼ How to Prepare for Adding Diskless Clients

Make sure that the system intended to be the OS service is running a supported release. Also verify that the combination of OS server release and diskless client release is supported.

When you use the `smosservice add` command to add OS services, you must specify the *platform*, *mediapath*, and *cluster* (or software group) of each diskless client platform that you want to support.

1. Verify that the intended OS server and diskless client will be running a combination of Solaris releases that are supported.

For more information, see “OS Server and Diskless Client Support Information” on page 124.

2. Identify the diskless client platform by using this format:

instruction_set.machine_class.Solaris_version

For example:

`sparc.sun4u.Solaris_9`

The following are the possible platform options:

<i>instruction_set</i>	<i>machine_class</i>	<i>Solaris_version</i>
sparc	sun4d*, sun4c*, sun4m*, sun4u,	Solaris_9, Solaris_8, Solaris_2.7, Solaris_2.6
i386	i86pc	Solaris_9, Solaris_8, Solaris_2.7, Solaris_2.6

* The sun4c architecture is not supported in the Solaris 8 or Solaris 9 releases. The sun4d architecture is not supported in the Solaris 9 releases.

3. Identify the media path, which is the full path to the disk image that contains the operating system that you want to install for the diskless client.

The Solaris operating environment is delivered on multiple CDs. However, you cannot use the `smosservice` command to load OS services from a multiple CD distribution. You must run the scripts that are found on the Solaris software CDs (and optional Language CD) to do the following:

- Create an install image on a server. For information on setting up an install server, refer to *Solaris 9 12/03 Installation Guide*.
- Load the required OS services from the CD image using one of the following scripts:
 - CD 1 of 2 –
`/cdrom/cdrom0/s0/Solaris_9/Tools/setup_install_server`

- CD 2 of 2 –
/cdrom/cdrom0/s0/Solaris_9/Tools/add_to_install_server
- Language CD –
/cdrom/cdrom0/s0/Solaris_9/Tools/add_to_install_server

For example, if you are using the `setup_install_server` script from the Solaris 9 Software 1 of 2 SPARC Platform Edition CD on a locally connected CD-ROM device, the syntax looks something like this:

```
# mkdir /export/install/sparc_9
# cd /cd_mount_point/Solaris_9/Tools
# ./setup_install_server /export/install/sparc_9
```

- After the Solaris CD image is installed on the disk, specify the disk image path. For example:

```
/net/export/install/sparc_9
```

4. Identify the `SUNWCXall` cluster when you add OS services.

You must use *the same cluster* for diskless clients that run the same operating environment on the same system (SPARC or x86).

For example, consider the following diskless clients:

- `sparc.sun4m.Solaris_9`
- `sparc.sun4u.Solaris_9`

To set up these diskless clients, you would need to specify the `SUNWCXall` cluster for each diskless client because the `sun4u` and `sun4m` systems require the `SUNWCXall` cluster. In addition, diskless clients that run the same operating environment (in this situation, `Solaris_9`) on the same system must use the same cluster.

Note – If you are using a `sun4u` system, or if you are using a system with an accelerated 8-bit color memory frame buffer (`cgsix`), you *must* specify `SUNWCXall` as the cluster.

▼ How to Add OS Services For Diskless Client Support

Use this procedure to add OS services for a diskless client on the server.

1. Become superuser or assume an equivalent role on the server.

For more information, see “How to Become Superuser (root) or Assume a Role” on page 48.

2. Verify that the Solaris Management Console server is running and that the diskless client tools are available on the system.

```
# /usr/sadm/bin/smosservice list -H starbug:898 --
Loading Tool: com.sun.admin.osservicemgr.cli.OsServerMgrCli from starbug:898
Login to starbug as user root was successful.
Download of com.sun.admin.osservicemgr.cli.OsServerMgrCli from starbug:898
was successful.
Platform
-----
```

3. Add the OS services.

```
# /usr/sadm/bin/smosservice add -H hostname:898 -- -o hostname
-x mediapath=path -x platform=instruction-set.machine-class.Solaris-version
-x cluster=cluster-name -x locale=locale-name
```

add	Adds the specified OS service.
-H hostname:898	Specifies the host name and port to which you want to connect. If you do not specify a port, the system connects to the default port, 898.
--	Identifies that the subcommand arguments start after this point.
-x mediapath=path	Specifies the full path to the Solaris image.
-x platform=instruction-set.machine-class.Solaris-version	Specifies the instruction architecture, machine class, and the Solaris version to be added.
-x cluster=cluster-name	Specifies the Solaris cluster to install.
-x locale=locale-name	Specifies the locale to install.

Note – The installation process can take approximately 45 minutes, depending on the server speed and the OS service configuration you choose.

For more information, see `smoservice(1M)`.

4. (Optional) Continue to add the other OS services.

5. When you are finished adding OS services, verify that the OS services were installed.

```
# /usr/sadm/bin/smosservice list -H hostname:898 --
```

Example—Adding an OS Service for Diskless Client Support

This example describes how to add Solaris 8 OS services on the server `starbug`. The server `starbug` is running the Solaris 9 release.

```
# /usr/sadm/bin/smosservice add -H starbug:898 -- -o starbug
-x mediapath=/net/install/export/sparc_8 -x platform=sparc.sun4u.Solaris_8
-x cluster=SUNWCXall -x locale=en_US
Authenticating as user: root

Type /? for help, pressing enter accepts the default denoted by [ ]
Please enter a string value for: password :: xxx
Loading Tool: com.sun.admin.osservicemgr.cli.OsServerMgrCli from starbug:898
Login to starbug as user root was successful.
Download of com.sun.admin.osservicemgr.cli.OsServerMgrCli from starbug:898
was successful.
```

▼ How to Add a Diskless Client

Use this procedure to add a diskless client after you have added OS services.

1. Become superuser or assume an equivalent role.

For more information, see “How to Become Superuser (root) or Assume a Role” on page 48.

2. Add the diskless client.

```
# /usr/sadm/bin/smdiskless add -- -i ip-address -e ethernet-address
-n client-name -x os=instruction-set.machine-class.Solaris-version
-x root=/export/root/client-name -x swap=/export/swap/client-name
-x swapsize=size -x tz=timezone -x locale=locale-name
```

<code>add</code>	Adds the specified diskless client.
<code>--</code>	Identifies that the subcommand arguments start after this point.
<code>-i ip-address</code>	Identifies the IP address of the diskless client.
<code>-e ethernet-address</code>	Identifies the Ethernet address of the diskless client.
<code>-n client-name</code>	Specifies the name of the diskless client.
<code>-x os=instruction-set.machine-class.Solaris-version</code>	Specifies the instruction architecture, machine class, OS, and the Solaris version for the diskless client.

<code>-x root=root=/export/root/client-name</code>	Identifies the root directory for the diskless client.
<code>-x swap=root=/export/root/client-name</code>	Identifies the swap file for the diskless client.
<code>-x swapsize=size</code>	Specifies the size of the swap file in Mbytes. The default is 24 Mbytes.
<code>-x tz=timezone</code>	Specifies the timezone for the diskless client.
<code>-x locale=locale-name</code>	Specifies the locale to install for the diskless client.

For more information, see `smdiskless(1M)`.

3. (Optional) Continue to use the `smdiskless add` command to add each diskless client.
4. Verify that the diskless clients were installed.

```
# /usr/sadm/bin/smosservice list -H hostname:898 --
```

Examples—Adding a Diskless Client

This example shows how to add a Solaris 8 client, `holoship`, from the server `starbug`.

```
# /usr/sadm/bin/smdiskless add -- -i 172.20.27.103 -e 8:0:20:92:4e:f3
-n holoship -x os=sparc.sun4u.Solaris_8 -x root=/export/root/holoship
-x swap=/export/swap/holoship -x swapsize=128 -x tz=US/Mountain
-x locale=en_US
```

This example shows how to add a Solaris 7 client, `inquisitor`, from the server `starbug`.

```
# /usr/sadm/bin/smdiskless add -- -i 172.20.27.102 -e 8:0:20:1f:31:be
-n inquisitor -x os=sparc.sun4u.Solaris_2.7 -x root=/export/root/inquisitor
-x swap=/export/swap/inquisitor -x swapsize=64 -x tz=US/Mountain
```

▼ How to Boot a Diskless Client

1. Verify the following prerequisites on the OS server:
 - Confirm that the name service used to add the diskless client and the OS services matches the primary name in the server's `/etc/nsswitch.conf` file. Otherwise, the diskless client won't boot.
 - Confirm that the `rpc.bootparamd` daemon is running. If it is not running, start it.

2. **Boot the diskless client.**

```
ok boot net
```

▼ How to Delete Diskless Client Support

1. **Become superuser or assume an equivalent role.**

For more information, see “How to Become Superuser (root) or Assume a Role” on page 48.

2. **Remove the diskless client support.**

```
# /usr/sadm/bin/smdiskless delete -- -o hostname:898 -n client-name
```

3. **Verify that the diskless client support is removed.**

```
# /usr/sadm/bin/smosservice list -H hostname:898 --
```

Example—Deleting Diskless Client Support

This example shows how to delete the diskless client holoship from the OS server starbug.

```
# /usr/sadm/bin/smdiskless delete -- -o starbug -n holoship
Authenticating as user: root
```

```
Type /? for help, pressing enter accepts the default denoted by [ ]
Please enter a string value for: password ::
Starting SMC server version 2.0.0.
endpoint created: :898
SMC server is ready.
Loading Tool: com.sun.admin.osserversmgr.cli.OsServerMgrCli from starbug
Login to starbug as user root was successful.
Download of com.sun.admin.osserversmgr.cli.OsServerMgrCli from starbug
was successful.
```

▼ How to Delete OS Services for Diskless Clients

1. **Become superuser or assume an equivalent role.**

For more information, see “How to Become Superuser (root) or Assume a Role” on page 48.

2. **Remove the OS services for the diskless clients.**

```
# /usr/sadm/bin/smosservice delete -H hostname:898 --
-x rmpatform=instruction-set.machine-class.Solaris-version
```

3. **Verify that the OS services are removed.**

```
# /usr/sadm/bin/smosservice list -H hostname:898 --
```

Example—Deleting OS Services for Diskless Clients

The following example shows how to delete the diskless client OS services (sparc.all.Solaris_9) from the server starbug.

```
# /usr/sadm/bin/smosservice delete -H starbug:898 --  
-x rplatform=sparc.all.Solaris_9  
Authenticating as user: root  
Type /? for help, pressing enter accepts the default denoted by [ ]  
Please enter a string value for: password ::  
Loading Tool: com.sun.admin.osservmgrp.cli.OsServerMgrCli from starbug:898  
Login to starbug as user root was successful.  
Download of com.sun.admin.osservmgrp.cli.OsServerMgrCli from starbug:898  
was successful.
```

Patching Diskless Client OS Services

You use the `smosservice patch` command to do the following:

- Establish the `/export/diskless/Patches` patch spool directory on an OS server.
- Add patches to the patch spool directory. If the patch you are adding obsoletes an existing patch in the spool, the obsolete patch is moved to `/export/diskless/Patches/Archive`.
- Delete patches from the patch spool directory.
- List the patches in the patch spool directory.
- Synchronize spooled patches out to clients. You must reboot each synchronized client for the client to recognize the patch update.

Note – Keep your OS servers up to date by installing recommended OS patches on a timely basis.

For information on downloading patches, see “How to Download an Unsigned Solaris Patch” on page 358.

Displaying OS Patches for Diskless Clients

Diskless client patches are logged in different directories, depending on the type of patch:

- Kernel patches are logged in the diskless client's `/var/sadm/patch` directory. To display kernel patches, type the following command on the diskless client:

```
% patchadd -p
```

- `/usr` patches are logged in the OS server's `/export/Solaris_version/var/patch` directory. A directory is created for each patch ID. To display `/usr` patches, type the following command on the OS server:

```
% patchadd -S Solaris_8 -p
```

```
Patch: 111879-01 Obsoletes: Requires: Incompatibles: Packages: SUNWwsr
```

To list all spooled patches by OS and architecture, use the `smoservice` command with the `-P` option.

▼ How to Add an OS Patch for a Diskless Client

1. **Become superuser or assume an equivalent role on the server.**

For more information, see “How to Become Superuser (root) or Assume a Role” on page 48.

2. **Log in to the diskless client system and shut it down.**

```
# init 0
```

3. **Add the patch to a spool directory.**

```
# /usr/sadm/bin/smoservice patch -- -a /var/patches/patch-ID-revision
Authenticating as user: root
```

```
Type /? for help, pressing <enter> accepts the default denoted by [ ]
Please enter a string value for: password ::
Loading Tool: com.sun.admin.ossvermgr.cli.OsServerMgrCli from starbug
Login to starbug as user root was successful.
Download of com.sun.admin.ossvermgr.cli.OsServerMgrCli from starbug
was successful.
```

If the patch to add depends on another patch, adding the patch fails with the following message:

```
The patch patch-ID-revision could not be added
because it is dependent on other patches which have not yet been spooled.
You must add all required patches to the spool first.
```

4. **Verify the patch is spooled.**

```
# /usr/sadm/bin/smoservice patch -- -P
```

5. **Push the spooled patch to the diskless client.**

```
# /usr/sadm/bin/smoservice patch -- -m -U
Authenticating as user: root
```

```
Type /? for help, pressing <enter> accepts the default denoted by [ ]
```

```

Please enter a string value for: password ::
Loading Tool: com.sun.admin.osservicemgr.cli.OsServerMgrCli from starbug
Login to starbug as user root was successful.
Download of com.sun.admin.osservicemgr.cli.OsServerMgrCli from starbug
was successful.

```

Note – Pushing and synchronizing the patch to the diskless client can take up to 90 minutes per patch.

6. Verify the patch is applied to the diskless client.

```

# /usr/sadm/bin/smosservice patch -- -P
Authenticating as user: root

Type /? for help, pressing <enter> accepts the default denoted by [ ]
Please enter a string value for: password ::
Loading Tool: com.sun.admin.osservicemgr.cli.OsServerMgrCli from starbug
Login to starbug as user root was successful.
Download of com.sun.admin.osservicemgr.cli.OsServerMgrCli from starbug
was successful.
Patches In Spool Area
Os Rel Arch   Patch Id   Synopsis
-----
8             sparc     111879-01 SunOS 5.8: Solaris Product Registry patch SUNWwsr

Patches Applied To OS Services
Os Service                                Patch
-----
Solaris_8

Patches Applied To Clone Areas
Clone Area                                Patch
-----
Solaris_8/sun4u

```

Example—Adding an OS Patch for a Diskless Client

This example shows how to add a Solaris 8 patch (111879-01) to the diskless client's OS services on the server.

```

# /usr/sadm/bin/smosservice patch -- -a /var/patches/111879-01
Authenticating as user: root
.
.
.
# /usr/sadm/bin/smosservice patch -- -P
Patches In Spool Area
Os Rel Arch   Patch Id   Synopsis
-----
8             sparc     111879-01 SunOS 5.8: Solaris Product Registry patch SUNWwsr

```

```

.
.
.
# /usr/sadm/bin/smosservice patch -- -m -U
Authenticating as user: root
.
.
.
# /usr/sadm/bin/smosservice patch -- -P
Authenticating as user: root
.
.
.
Patches In Spool Area
Os Rel Arch Patch Id Synopsis
-----
8 sparc 111879-01 SunOS 5.8: Solaris Product Registry patch SUNWwsr

Patches Applied To OS Services
Os Service Patch
-----
Solaris_8

Patches Applied To Clone Areas
Clone Area Patch
-----
Solaris_8/sun4u

```

Troubleshooting Diskless Client Problems

This section lists some common problems with diskless clients and possible solutions.

Problem

- OS server does not respond to client RARP requests
- OS server does not respond to client bootparam requests
- OS server cannot mount diskless client root file system

Solution

In a files environment

- Verify that `files` is listed as the first source for `hosts`, `ethers`, and `bootparams` in the `/etc/nsswitch.conf` file on the OS server.
- Verify that the client's IP address appears in the `/etc/inet/hosts` file.
- Verify that the client's Ethernet address appears in the `/etc/ethers` file.
- Verify that the `/etc/bootparams` file contains the following paths to the client's root and swap areas:

```
client root=os-server:/export/root/client swap=os-server:
/export/swap/client
```

The swap size varies depending on whether you specify the `-x swaptsize` option when you add the diskless client. If you specify the `-x dump` option when you add the diskless client, the following line is present:

```
dump=os-server:/export/dump/client dumpsize=24
```

The dump size varies depending on whether you specify the `-x dumpsize` option when you add the diskless client.

- Verify that the OS server's IP address appears in the `/export/root/client/etc/inet/hosts` file.

In a name service environment

- Verify that both the OS server's and the client's Ethernet address and IP address are correctly mapped.
- Verify that the `/etc/bootparams` file contains the paths to the client's root and swap areas, as follows:

```
client root=os-server:/export/
root/client swap=os-server:/export/
swap/client swaptsize=24
```

The swap size varies depending on whether you specify the `-x swaptsize` option when you add the diskless client. If you specify the `-x dump` option when you add the diskless client, the following line is present:

```
dump=os-server:/export/dump/client dumpsize=24
```

The dump size varies depending on whether you specify the `-x dumpsize` option when you add the diskless client.

Problem

Diskless client panics

Solution

- Verify that the OS server's Ethernet address is correctly mapped to its IP address. If you physically moved a system from one network to another, you might have forgotten to remap the system's new IP address.
- Verify that the client's host name, IP address, and Ethernet address do not exist in the database of another server *on the same subnet* that responds to the client's RARP, TFTP, or bootparam requests. Often, test systems are set up to install their OS from an install server. In these cases, the install server answers the client's RARP or bootparam request, returning an incorrect IP address. This incorrect address might result in the download of a boot program for the wrong architecture, or a failure to mount the client's root file system.
- Verify that the diskless client's TFTP requests are not answered by an install server (or previous OS server) that transfers an incorrect boot program. If the boot program is of a different architecture, the client immediately panics. If the

boot program loads from a non-OS server, the client might obtain its root partition from the non-OS server and its `/usr` partition from the OS server. In this situation, the client panics if the root and `/usr` partitions are of conflicting architectures or versions.

- If you are using both an install server and an OS server, verify that the following entry exists in the `/etc/dfs/dfstab` file:

```
share -F nfs -o -ro /export/exec/Solaris_version_instruction_set.all/usr
```

Where `version=2.6, 2.7, 8, 9`, and `instruction_set=sparc` or `i386`.

- Verify that the diskless client's root, `/swap`, and `/dump` (if specified) partitions have share entries:

```
share -F nfs -o rw=client,root=client /export/root/client
share -F nfs -o rw=client,root=client /export/swap/client
share -F nfs -o rw=client,root=client /export/dump/client
```

- On the OS server, type the following to check which files are shared:

```
% share
```

The OS server must share `/export/root/client` and `/export/swap/client_name` (defaults), or the root, `/swap`, and `/dump` partitions you specified when you added the diskless client.

Verify that the following entries exist in the `/etc/dfs/dfstab` file:

```
share -F nfs -o ro /export/exec/Solaris_version_instruction_set.all/usr
share -F nfs -o rw=client,root=client /export/root/client
share -F nfs -o rw=client,root=client /export/swap/client
```

Problem

OS server is not responding to diskless client's RARP request

Solution

From the client's intended OS server, run the `snoop` command as root by using the client's Ethernet address:

```
# snoop xx:xx:xx:xx:xx:xx
```

Problem

Boot program downloads, but panics early in the process

Solution

Using the `snoop` command, verify that the intended OS server is answering the client's TFTP and NFS requests.

Problem

- Diskless client hangs
- Incorrect server responds to diskless client's RARP request

Solution

Restart the following daemons on the OS server:

```
# /usr/sbin/rpc.bootparamd  
# /usr/sbin/in.rarpd -a
```

Shutting Down and Booting a System Topics

This topic map lists the chapters that provide information on shutting down and booting a system.

Chapter 10	Provides overview information and guidelines for shutting down and booting a system.
Chapter 11	Provides overview information and tasks that are related to run levels and boot files.
Chapter 12	Provides step-by-step instructions for shutting down a system.
Chapter 13	Provides step-by-step instructions for booting a SPARC based system.
Chapter 14	Provides step-by-step instructions for booting an x86 based system.
Chapter 15	Provides a high-level overview of the boot process for both SPARC based and x86 based systems.

Shutting Down and Booting a System (Overview)

This chapter provides guidelines for shutting down and booting a system. The Solaris software environment is designed to run continuously so that electronic mail and network resources are available to users. Occasionally, it is necessary to shut down or reboot a system because of a system configuration change, a scheduled maintenance event, or a power outage.

This is a list of the overview information in this chapter.

- “What’s New in Shutting Down and Booting a System?” on page 147
- “Where to Find Shutting Down and Booting Tasks” on page 148
- “Shutting Down and Booting Terminology” on page 149
- “Guidelines for Shutting Down a System” on page 149
- “Guidelines for Booting a System” on page 150
- “Booting a System From the Network” on page 150
- “When to Shut Down a System” on page 151
- “When to Boot a System” on page 152

What’s New in Shutting Down and Booting a System?

This section describes new features that are related to shutting down and booting a system in the Solaris 9 release.

PXE Network Boot

You can boot the Solaris x86 Platform Edition directly from a network without the Solaris boot diskette on x86 based systems that support the Preboot Execution Environment (PXE) network booting protocol. The PXE network boot is available only for devices that implement the Intel Preboot Execution Environment specification.

You can enable the PXE network boot on the client system by using the BIOS setup program in the system BIOS, the network adapter BIOS, or both. On some systems, you must also adjust the boot device priority list so that a network boot is attempted before a boot from other devices. See the manufacturer's documentation for each setup program, or watch for setup program entry instructions during boot.

Some PXE-capable network adapters have a feature that enables a PXE boot if you type a particular keystroke in response to a brief boot-time prompt. This feature is ideal when you use PXE for an install boot on a system that normally boots from the disk drive because you do not have to modify the PXE settings. If your adapter does not have this feature, disable PXE in the BIOS setup when the system reboots after installation, and the system will boot from the disk drive.

Some early versions of PXE firmware cannot boot the Solaris system. If you have one of these older versions, your system can read the PXE network bootstrap program from a boot server, but the bootstrap will not transmit packets. If this problem occurs, upgrade the PXE firmware on the adapter. Obtain firmware upgrade information from the adapter manufacturer's web site. For more information, see `e1x1(7D)` and `iprb(7D)`.

For information on booting x86 based systems with or without the boot diskette, see "x86: How to Boot a System From the Network" on page 203.

Where to Find Shutting Down and Booting Tasks

Use these references to find step-by-step instructions for shutting down and booting a system.

Shut Down and Boot Task	For More Information
Shut down a SPARC based system or an x86 based system	Chapter 12
Boot a SPARC based system	Chapter 13

Shut Down and Boot Task	For More Information
Boot an x86 based system	Chapter 14
Manage a SPARC based system with the power management software	<code>power.conf(4)</code> , <code>pmconfig(1M)</code>

Shutting Down and Booting Terminology

This section describes the terminology that is used in shutting down and booting a system.

- **Run levels and init states** – A *run level* is a letter or digit that represents a system state in which a particular set of system services are available. The system is always running in one of a set of well-defined run levels. Run levels are also referred to as *init states* because the `init` process is used to perform transitions between run levels. System administrators use the `init` command to initiate a run-level transition. This book refers to init states as run levels.

For more information about run levels, see “Run Levels” on page 155.

- **Boot types** – A *boot type* describes how a system is booted. Different boot types include the following:
 - Interactive boot – You are prompted to provide information about how the system is booted, such as the kernel and device path name.
 - Reconfiguration boot – The system is reconfigured to support newly added hardware or new pseudo devices.
 - Recovery boot – The system is hung or an invalid entry is prohibiting the system from booting successfully or from allowing users to log in.

Guidelines for Shutting Down a System

Keep the following in mind when you shut down a system:

- Use the `init` and `shutdown` commands to shut down a system. Both commands perform a clean system shutdown, which means that all system processes and services are terminated normally.
- Use the `shutdown` command to shut down a server, because logged-in users and systems that mount resources from the server are notified before the server is shut down. Additional notification of system shutdowns by electronic mail is also

recommended so that users can prepare for system downtime.

- You need superuser privileges to use the `shutdown` or `init` command to shut down a system.
- Both `shutdown` and `init` commands take a run level as an argument. The three most common run levels are as follows:
 - Run level 3 – Means that all system resources are available and users can log in. By default, booting a system brings it to run level 3, which is used for normal day-to-day operations. Also known as multiuser level with NFS resources shared.
 - Run level 6 – Stops the operating system and reboots to the state that is defined by the `initdefault` entry in the `/etc/inittab` file.
 - Run level 0 – Means that the operating system is shut down and it is safe to turn off power. You need to bring a system to run level 0 whenever you move a system, or add or remove hardware.

Run levels are fully described in Chapter 11.

Guidelines for Booting a System

Keep the following in mind when you boot a system:

- After a system is shut down, it is booted by using the `boot` command at the PROM level on a SPARC based system or by using the `boot` command at the Primary Boot Subsystem Menu on an x86 based system.
- A system can be rebooted by turning the power off and then back on. This method is not a clean shutdown because system services and processes are terminated abruptly. However, turning a system's power off and back on is an alternative for emergency situations.
- SPARC based systems and x86 based systems use different hardware components for booting. These differences are described in Chapter 15.

Booting a System From the Network

You might need to boot a system from the network under the following situations:

- When the system is first installed.
- If the system won't boot from the local disk.
- If the system is a diskless client.

In addition, there are two network configuration boot strategies available:

- RARP (Reverse Address Resolution Protocol and ONC+ RPC Bootparams Protocol)
- DHCP (Dynamic Host Configuration Protocol)

The default network boot strategy is set to RARP.

Use this table if you need information on booting a system over the network.

Network Boot Task	For More Information
Boot a SPARC system or a SPARC diskless client	Chapter 13
Boot an x86 system or an x86 diskless client	Chapter 14
Boot a DHCP client during installation	<i>Solaris 9 12/03 Installation Guide</i>
Configure a DHCP client with DHCP Manager	<i>System Administration Guide: IP Services</i>

When to Shut Down a System

The following table provides a list of system administration tasks and the type of shut down that is needed to initiate the task.

TABLE 10-1 Shutting Down a System

Reason for System Shut Down	Appropriate Run Level	For More Information
To turn off system power due to anticipated power outage	Run level 0, where it is safe to turn off power	Chapter 12
To change kernel parameters in the <code>/etc/system</code> file	Run level 6 (reboot the system)	Chapter 12
To perform file system maintenance, such as backing up or restoring system data	Run level S (single-user level)	Chapter 12
To repair a system configuration file such as <code>/etc/system</code>	See “When to Boot a System” on page 152	N/A
To add or remove hardware from the system	Reconfiguration boot (also to turn off power when adding or removing hardware)	Chapter 27

TABLE 10-1 Shutting Down a System (Continued)

Reason for System Shut Down	Appropriate Run Level	For More Information
To repair an important system file which is causing system boot failure	See “When to Boot a System” on page 152	N/A
To boot the kernel debugger (kadb) to track down a system problem	Run level 0, if possible	Chapter 12
To recover from a hung system and you want to force a crash dump	See “When to Boot a System” on page 152	N/A

For examples of shutting down a server or a standalone system, see Chapter 12.

When to Boot a System

The following table provides a list of system administration tasks and the corresponding boot type that is used to complete the task.

TABLE 10-2 Booting a System

Reason for System Reboot	Appropriate Boot Type	Information for SPARC Procedure	Information for x86 Procedure
To turn off system power due to anticipated power outage	Turn system power back on	Chapter 12	Chapter 12
To change kernel parameters in the <code>/etc/system</code> file	Reboot the system to run level 3 (multiuser level with NFS resources shared)	“SPARC: How to Boot a System to Run Level 3 (Multiuser Level)” on page 186	“x86: How to Boot a System to Run Level 3 (Multiuser Level)” on page 199
To perform file system maintenance, such as performing a backup or restoring system data	Use Control-D from run level S to bring the system back to run level 3	“SPARC: How to Boot a System to Run Level S (Single-User Level)” on page 187	“x86: How to Boot a System to Run Level S (Single-User Level)” on page 200
To repair a system configuration file such as <code>/etc/system</code>	Interactive boot	“SPARC: How to Boot a System Interactively” on page 188	“x86: How to Boot a System Interactively” on page 201

TABLE 10–2 Booting a System (Continued)

Reason for System Reboot	Appropriate Boot Type	Information for SPARC Procedure	Information for x86 Procedure
To add or remove hardware from the system	Reconfiguration boot (also to turn on system power after adding or removing hardware)	“SPARC: How to Connect a Secondary Disk and Boot” on page 483	“x86: How to Connect a Secondary Disk and Boot” on page 493
To boot the kernel debugger (kadb) to track down a system problem	Booting kadb	“SPARC: How to Boot the System With the Kernel Debugger (kadb)” on page 193	“x86: How to Boot a System With the Kernel Debugger (kadb)” on page 209
To repair an important system file that is causing system boot failure	Recovery boot	“SPARC: How to Boot a System for Recovery Purposes” on page 191	“x86: How to Boot a System for Recovery Purposes” on page 204
To recover from a hung system and you want to force a crash dump	Recovery boot	See example on “SPARC: How to Force a Crash Dump and Reboot the System” on page 194	See example on “x86: How to Force a Crash Dump and Reboot the System” on page 210

For examples of booting a system, see Chapter 13 or Chapter 14.

Run Levels and Boot Files (Tasks)

This chapter provides overview information and tasks that are related to run levels and boot files.

This is a list of the step-by-step instructions in this chapter.

- “How to Use a Run Control Script to Stop or Start a Service” on page 165
- “How to Add a Run Control Script” on page 166
- “How to Disable a Run Control Script” on page 167

This is a list of the overview information in this chapter.

- “Run Levels” on page 155
- “The `/etc/inittab` File” on page 157
- “Run Control Scripts” on page 160
- “x86: Boot Files” on page 167

Run Levels

A system’s *run level* (also known as an *init state*) defines what services and resources are available to users. A system can be in only one run level at a time.

The Solaris environment has eight run levels, which are described in the following table. The default run level is specified in the `/etc/inittab` file as run level 3.

TABLE 11-1 Solaris Run Levels

Run Level	Init State	Type	Purpose
0	Power-down state	Power-down	To shut down the operating system so that it is safe to turn off power to the system.
s or S	Single-user state	Single-user	To run as a single user with some file systems mounted and accessible.
1	Administrative state	Single-user	To access all available file systems. User logins are disabled.
2	Multiuser state	Multiuser	For normal operations. Multiple users can access the system and all file system. All daemons are running except for the NFS server daemons.
3	Multiuser level with NFS resources shared	Multiuser	For normal operations with NFS resources shared. This is the default run level for the Solaris environment.
4	Alternative multiuser state		Currently unavailable.
5	Power-down state	Power-down	To shut down the operating system so that it is safe to turn off power to the system. If possible, automatically turns off power on systems that support this feature.
6	Reboot state	Reboot	To shut down the system to run level 0, and then reboot to multiuser level with NFS resources shared (or whatever level is the default in the <code>inittab</code> file).

How to Determine a System's Run Level

Display run level information by using the `who -r` command.

```
$ who -r
```

Use the `who -r` command to determine a system's current run level for any level, except run level 0.

Example—Determining a System’s Run Level

This example displays information a system’s current run level and information about previous run levels.

```
$ who -r
.      run-level 31  Dec 13 10:102  33  04 S5
$
```

1. Identifies the current run level
2. Identifies the date of last run level change
3. Also identifies the current run level
4. Identifies the number of times the system has been at this run level since the last reboot
5. Identifies the previous run level

The /etc/inittab File

When you boot the system or change run levels with the `init` or `shutdown` command, the `init` daemon starts processes by reading information from the `/etc/inittab` file. This file defines three important items for the `init` process:

- The system’s default run level
- What processes to start, monitor, and restart if they terminate
- What actions to take when the system enters a new run level

Each entry in the `/etc/inittab` file has the following fields:

id : *rstate* : *action* : *process*

The following table describes the fields in an `inittab` entry.

TABLE 11–2 Fields Descriptions for the `inittab` File

Field	Description
<i>id</i>	Is a unique identifier for the entry.
<i>rstate</i>	Lists the run levels to which this entry applies.

TABLE 11–2 Fields Descriptions for the `inittab` File (Continued)

Field	Description
<i>action</i>	Identifies how the process that is specified in the process field is to be run. Possible values include: <code>initdefault</code> , <code>sysinit</code> , <code>boot</code> , <code>bootwait</code> , <code>wait</code> , and <code>respawn</code> . <code>initdefault</code> identifies the default run level. For a description of the other action keywords, see <code>inittab(4)</code> .
<i>process</i>	Defines the command or script to execute.

Example—Default `inittab` File

The following example shows an annotated default `inittab` file that is installed with the Solaris release:

```

1 ap::sysinit:/sbin/autopush -f /etc/iu.ap
2 ap::sysinit:/sbin/soconfig -f /etc/sock2path
3 fs::sysinit:/sbin/rcS sysinit >/dev/msglog 2<>/dev/msglog </dev/console
4 is:3:initdefault:
5 p3:s1234:powerfail:/usr/sbin/shutdown -y -i5 -g0 >/dev/msglog 2<>/dev/...
6 sS:s:wait:/sbin/rcS >/dev/msglog 2<>/dev/msglog </dev/console
7 s0:0:wait:/sbin/rc0 >/dev/msglog 2<>/dev/msglog </dev/console
8 s1:1:respawn:/sbin/rc1 >/dev/msglog 2<>/dev/msglog </dev/console
9 s2:23:wait:/sbin/rc2 >/dev/msglog 2<>/dev/msglog </dev/console
10 s3:3:wait:/sbin/rc3 >/dev/msglog 2<>/dev/msglog </dev/console
11 s5:5:wait:/sbin/rc5 >/dev/msglog 2<>/dev/msglog </dev/console
12 s6:6:wait:/sbin/rc6 >/dev/msglog 2<>/dev/msglog </dev/console
13 fw:0:wait:/sbin/uadmin 2 0 >/dev/msglog 2<>/dev/msglog </dev/console
14 of:5:wait:/sbin/uadmin 2 6 >/dev/msglog 2<>/dev/msglog </dev/console
15 rb:6:wait:/sbin/uadmin 2 1 >/dev/msglog 2<>/dev/msglog </dev/console
16 sc:234:respawn:/usr/lib/saf/sac -t 300
17 co:234:respawn:/usr/lib/saf/ttymon -g -h -p "`uname -n` console login: "
    -T terminal-type -d /dev/console -l console
-m ldterm,ttcompat

```

1. Initializes STREAMS modules
2. Configures socket transport providers
3. Initializes file systems
4. Defines default run level
5. Describes a power fail shutdown
6. Defines single-user level
7. Defines run level 0
8. Defines run level 1
9. Defines run level 2
10. Defines run level 3
11. Defines run level 5
12. Defines run level 6
13. Defines an unused level, firmware

- 14. Defines an unused level, off
- 15. Defines an unused level, reboot
- 16. Initializes Service Access Controller
- 17. Initializes console and identifies the terminal type

What Happens When the System Is Brought to Run Level 3

1. The `init` process is started and reads the `/etc/default/init` file to set any environment variables. By default, only the `TIMEZONE` variable is set.
2. Then `init` reads the `inittab` file and does the following:
 - a. Identifies the `initdefault` entry, which defines the default run level (3).
 - b. Executes any process entries that have `sysinit` in the `action` field so that any special initializations can take place before users login.
 - c. Executes any process entries that have a 3 in the `rstate` field, which matches the default run level, 3.

For a detailed description of how the `init` process uses the `inittab` file, see `init(1M)`.

The following table describes the keywords used for run level 3's `action` field.

TABLE 11-3 Run Level 3 Action Keyword Descriptions

Key Word	Description
<code>powerfail</code>	Starts the process when the <code>init</code> process receives a power failure signal
<code>respawn</code>	Starts the process and restarts it when it dies
<code>wait</code>	Starts the process and waits for it to finish before going on to the next entry for this run level

The following table describes the processes (or commands) that are executed at run level 3.

TABLE 11-4 Command Descriptions for Run Level 3

Command or Script Name	Description
<code>/usr/sbin/shutdown</code>	Shuts down the system. The <code>init</code> process runs the <code>shutdown</code> command only if the system has received a power fail signal.

TABLE 11-4 Command Descriptions for Run Level 3 (Continued)

Command or Script Name	Description
/sbin/rcS	Checks and mounts root (/), /usr, /tmp, /var, /var/adm, and /var/run file systems.
/sbin/rc2	Starts the standard system processes and brings the system up into run level 2 (multiuser level).
/sbin/rc3	Starts NFS resource sharing for run level 3.
/usr/lib/saf/sac -t 30	Starts the port monitors. This process is restarted if it fails.
/usr/lib/saf/ttymon -g -h -p "uname -n` console login: " -T <i>terminal_type</i> -d /dev/console -l console	Starts the ttymon process that monitors the console for login requests. This process is restarted if it fails. The <i>terminal_type</i> on a SPARC based system is sun. The <i>terminal_type</i> on an x86 based system is AT386.

Run Control Scripts

Note – The way system services are started and stopped in the Solaris environment might change in some future release.

The Solaris software environment provides a detailed series of run control (rc) scripts to control run-level changes. Each run level has an associated rc script that is located in the /sbin directory:

- rc0
- rc1
- rc2
- rc3
- rc5
- rc6
- rcS

For each rc script in the /sbin directory, there is a corresponding directory named /etc/rcn.d that contains scripts to perform various actions for that run level. For example, /etc/rc2.d contains files that are used to start and stop processes for run level 2.

```
# ls /etc/rc2.d
K03samba*      S20syssetup*   S72slpd*       S88utmpd*
K06mipagent*   S21perf*       S73cachefs.daemon* S89PRESERVE*
```

K07dmi*	S30sysid.net*	S73nfs.client*	S89bdconfig@
K07snmpdx*	S40llc2*	S74autofs*	S90wbem*
K16apache*	S42ncakmod*	S74syslog*	S91afbinit*
K21dhcp*	S47pppd*	S74xntpd*	S91gfbinit*
K26sshd*	S69inet*	S75cron*	S91ifbinit*
K27boot.server*	S70sckm*	S75flashprom*	S92volmgt*
K28kdc*	S70uucp*	S75savecore*	S93cacheos.finish*
K28kdc.master*	S71ldap.client*	S76nscd*	S94ncalogd*
K28nfs.server*	S71rpc*	S77sf880dr*	S95Iim*
README	S71sysid.sys*	S80lp*	S95svm.sync*
S01MOUNTFSYS*	S72autoinstall*	S80spc*	S98efcode*
S05RMTMPFILES*	S72directory@	S85power*	S99audit*
S10lu*	S72inetsvc*	S88sendmail*	S99dtlogin*

The `/etc/rcn.d` scripts are always run in ASCII sort order. The scripts have names of the form:

```
[KS] [0-9] [0-9] *
```

Files that begin with `K` are run to terminate (kill) a system service. Files that begin with `S` are run to start a system service.

Run control scripts are also located in the `/etc/init.d` directory. These files are linked to corresponding run control scripts in the `/etc/rcn.d` directories.

The actions of each run control script are summarized in the following section.

Run Control Script Summaries

The following sections summarize the run control scripts that are used to start and stop system services when you change run levels.

The `/sbin/rc0` Script

The `/sbin/rc0` script runs the `/etc/rc0.d` scripts to perform the following tasks:

- Stops system services and daemons
- Terminates all running processes
- Unmounts all file systems

The `/sbin/rc1` Script

The `/sbin/rc1` script runs the `/etc/rc1.d` scripts to perform the following tasks:

- Stops system services and daemons
- Terminates all running user processes
- Unmounts all remote file systems

- Mounts all local file systems if the previous run level was S

The `/sbin/rc2` Script

The `/sbin/rc2` script runs the `/etc/rc2.d` scripts to perform the following tasks, grouped by function:

Local system-related tasks:

- Mounts all local file systems if the previous run level was S
- Enables disk quotas if at least one file system was mounted with the `quota` option
- Saves temporary editor files in the `/usr/preserve` directory
- Removes any files and subdirectories in the `/tmp` directory
- Starts system activity data collecting, system accounting, and system auditing, if configured
- Starts the system logging daemon (`syslogd`), sets the default dump device, and rotates the `/var/adm/messages` file
- Sets the default scheduling class if the `/etc/dispatchadmin.conf` file exists
- Starts LP print service (`lpsched`) if a local printer is configured and cleans up the print queue
- Configures power management, if appropriate
- Starts the `utmpd` daemon
- Starts the `cron` and `vold` daemons
- Configures serial device stream
- Configures WBEM services
- Syncs volumes, if required, and starts the `mdmonitord` daemon to monitor the physical components of the volumes
- Starts the CDE desktop login process, `dtlogin`, if appropriate

Network service or security-related tasks:

- Configures the network interfaces, sets `ifconfig netmask`, and configures network routing, if appropriate
- Starts network service (`inetd` and `rpcbind`) daemons
- Starts the logical link controller (`llc2`), if configured
- Sets the name service domain name, starts various name services daemons, depending on if the system is configured for a name service, and whether the system is a client or a server
- Starts the `keyserv`, `statd`, `lockd`, and `xntpd` daemons, if appropriate
- Mounts all NFS entries
- Configures the Solaris Network Cache and Accelerator (NCA) and NCA logging, if appropriate

- Starts the Solaris PPP server or client daemons (pppoed or pppd), if configured
- Starts LDAP cache manager (ldap_cachemgr), if configured
- Starts directory server (slapd) daemon, if configured
- Starts DNS (in.named) daemon, if configured
- Starts Service Location Protocol (slpd) daemon, if configured
- Configures system resource controls and system pools if the /etc/rctladm.conf and /etc/pooladm.conf files exist
- Starts the cachefs, automount, and sendmail daemons, if appropriate
- Starts the http_server process

Install-related tasks:

- Configures the boot environment for the Live Upgrade software upon system startup or system shutdown
- Checks for the presence of the /etc/.UNCONFIGURE file to see if the system should be reconfigured
- Reboots the system from the installation media or a boot server if either / .PREINSTALL or /AUTOINSTALL exists

Hardware-related tasks:

- Starts the Sun Fire 15000 key management daemon (sckmd), if appropriate
- Starts the Sun Fire 880 Dynamic Reconfiguration daemon (sf880drd), if appropriate
- Runs the flash PROM update script
- Configures any graphic frame buffers or graphic accelerators
- Runs the FCode interpreter daemon (efdaemon), if necessary

Transitions the following services between run-level changes:

- Apache (tomcat)
- Boot server (in.rarpd), (rpc.bootparamd), or (rpld)
- DHCP (in.dhcpd)
- Kerberos KDC (krb5kdc) and Kerberos administration (kadmind)
- Mobile IP (mipagent)
- NFS server (nfsd), (mountd), (nfslogd)
- Samba (smbd) and (nmbd)
- Secure shell (sshd)
- Solstice Enterprise Agents (dmispd) and (snmpXdmid)

Note – Many of the system services and applications that are started at run level 2 depend on what software is installed on the system.

The /sbin/rc3 Script

The /sbin/rc3 script runs the /etc/rc3.d scripts to perform the following tasks:

- Starts the Apache server daemon (tomcat), if configured
- Starts the DHCP daemon (in.dhcpd), if appropriate
- Starts Kerberos KDC (krb5kdc) and Kerberos administration (kadmind) daemons, if configured
- Starts Mobile IP daemon (mipagent), if configured
- Starts the Samba daemons (smbd and nmbd), if configured
- Starts the secure shell daemon (sshd), if appropriate
- Starts the Solstice Enterprise Agents (dmispd and snmpXdmid)
- Cleans up the /etc/dfs/sharetab file
- Starts the NFS server daemons nfsd, mountd, and nfslogd, if appropriate
- If the system is a boot server, starts the rarpd, rpc.bootparamd, and rpld daemons

The /sbin/rc5 and /sbin/rc6 Scripts

The /sbin/rc5 and /sbin/rc6 scripts run the /etc/rc0.d/K* scripts to perform the following tasks:

- Kills all active processes
- Unmounts the file systems

The /sbin/rcS Script

The /sbin/rcS script runs the /etc/rcS.d scripts to bring the system up to run level S. The following tasks are performed by these scripts:

- Establishes a minimal network
- Checks and mounts root (/), /usr, /tmp, /var, /var/adm, and /var/run file systems.
- Sets the system name
- Mounts pseudo file systems (/proc and /dev/fd)
- Rebuilds the device entries for reconfiguration boots
- Checks and mounts other file systems to be mounted in single-user level

Using a Run Control Script to Stop or Start Services

Note – The way system services are started and stopped in Solaris environment might change in some future release.

One advantage of having individual scripts for each run level is that you can run scripts in the `/etc/init.d` directory individually to stop system services without changing a system's run level.

▼ How to Use a Run Control Script to Stop or Start a Service

1. **Become superuser.**

2. **Stop the system service.**

```
# /etc/init.d/filename stop
```

3. **Restart the system service.**

```
# /etc/init.d/filename start
```

4. **Verify that the service has been stopped or started.**

```
# pgrep -f service
```

Example—Using a Run Control Script to Stop or Start a Service

For example, you can stop the NFS server daemons by typing the following:

```
# /etc/init.d/nfs.server stop
# pgrep -f nfs
#
```

Then, you can restart the NFS server daemons by typing the following:

```
# /etc/init.d/nfs.server start
# pgrep -f nfs
341
343
347
345
# pgrep -f nfs -d, | xargs ps -fp
  UID  PID  PPID  C   STIME TTY          TIME CMD
  daemon  341    1   0   Aug 21 ?           0:00 /usr/lib/nfs/statd
```

```

root  343      1  0   Aug 21 ?           0:00 /usr/lib/nfs/lockd
root  347      1  0   Aug 21 ?           0:41 /usr/lib/nfs/nfsd
root  345      1  0   Aug 21 ?           0:02 /usr/lib/nfs/mountd

```

Adding a Run Control Script

Note – The way system services are started and stopped in the Solaris environment might change in some future release.

If you want to add a run control script to start and stop a service, copy the script into the `/etc/init.d` directory. Then, create links in the `rcn.d` directory where you want the service to start and stop.

See the README file in each `/etc/rcn.d` directory for more information on naming run control scripts. The following procedure describes how to add a run control script.

▼ How to Add a Run Control Script

1. **Become superuser.**

2. **Add the script to the `/etc/init.d` directory.**

```

# cp filename /etc/init.d
# chmod 0744 /etc/init.d/filename
# chown root:sys /etc/init.d/filename

```

3. **Create links to the appropriate `rcn.d` directory.**

```

# cd /etc/init.d
# ln filename /etc/rc2.d/Snnfilename
# ln filename /etc/rcn.d/Knnfilename

```

4. **Verify that the script has links in the specified directories.**

```

# ls /etc/init.d/ /etc/rc2.d/ /etc/rcn.d/

```

Example—Adding a Run Control Script

The following example shows how to add a run control script for the xyz service.

```

# cp xyz /etc/init.d
# chmod 0744 /etc/init.d/xyz
# chown root:sys /etc/init.d/xyz
# cd /etc/init.d

```

```
# ln xyz /etc/rc2.d/S100xyz
# ln xyz /etc/rc0.d/K100xyz
# ls /etc/init.d /etc/rc2.d /etc/rc0.d
```

Disabling a Run Control Script

You can disable a run control script by renaming it with an underscore (`_`) at the beginning of the file name. Files that begin with an underscore or dot are not executed. If you copy a file by adding a suffix to it, both files will be run.

▼ How to Disable a Run Control Script

1. **Become superuser.**
2. **Rename the script by adding an underscore (`_`) to the beginning of the new file.**

```
# cd /etc/rcn.d
# mv filename _filename
```

3. **Verify that the script has been renamed.**

```
# ls _*
# _filename
```

Example—Disabling a Run Control Script

The following example shows how to rename the `S100datainit` script.

```
# cd /etc/rc2.d
# mv S100datainit _S100datainit
# ls _*
# _S100datainit
```

x86: Boot Files

In addition to the run control scripts and boot files described previously, there are additional boot files that are associated with booting a Solaris x86 system.

TABLE 11-5 x86: Boot Files

File	Description
/etc/bootrc	Contains menus and options for booting the Solaris release.
/boot	Contains files and directories needed to boot the system.
/boot/mdboot	DOS executable that loads the first-level bootstrap program (<code>strap.com</code>) into memory from disk.
/boot/mdbootbp	DOS executable that loads the first-level bootstrap program (<code>strap.com</code>) into memory from diskette.
/boot/rc.d	Directory that contains install scripts. Do not modify the contents of this directory.
/boot/solaris	Directory that contains items for the boot subsystem.
/boot/solaris/boot.bin	Loads the Solaris kernel or standalone <code>kadb</code> . In addition, this executable provides some boot firmware services.
/boot/solaris/boot.rc	Prints the Solaris x86 Platform Edition and runs the Device Configuration Assistant in DOS-emulation mode.
/boot/solaris/bootconf.exe	DOS executable for the Device Configuration Assistant.
/boot/solaris/bootconf.txt	Text file that contains internationalized messages for Device Configuration Assistant (<code>bootconf.exe</code>).
/boot/solaris/bootenv.rc	Stores <code>eeprm</code> variables that are used to set up the boot environment.
/boot/solaris/devicedb	Directory that contains the <code>master</code> file, a database of all possible devices supported with realmode drivers.
/boot/solaris/drivers	Directory that contains realmode drivers.
/boot/solaris/itup2.exe	DOS executable run during install time update (ITU) process.
/boot/solaris/machines	Obsolete directory.
/boot/solaris/nbp	File associated with network booting.
/boot/solaris/strap.rc	File that contains instructions on what load module to load and where in memory it should be loaded.
/boot/strap.com	DOS executable that loads the second-level bootstrap program into memory.

Shutting Down a System (Tasks)

This chapter describes the procedures for shutting down systems. This is a list of the step-by-step instructions in this chapter.

- “How to Determine Who Is Logged in to a System” on page 171
- “How to Shut Down a Server” on page 171
- “How to Shut Down a Standalone System” on page 175
- “How to Turn Off Power to All Devices” on page 177

This is a list of the overview information in this chapter.

- “System Shutdown Commands” on page 170
- “User Notification of System Down Time” on page 171
- “Turning Off Power to All Devices” on page 176

For overview information about system run levels, see Chapter 11.

Shutting Down the System

Solaris software is designed to run continuously so that the electronic mail and network software can work correctly. However, some system administration tasks and emergency situations require that the system is shut down to a level where it is safe to remove power. In some cases, the system needs to be brought to an intermediate level, where not all system services are available, such as the following:

- Adding or removing hardware
- Preparing for an expected power outage
- Performing file system maintenance, such as a backup

For a complete list of system administration tasks that require a system shutdown, see Chapter 10.

For information on using your system's power management features, see *Solaris Common Desktop Environment: User's Guide*.

System Shutdown Commands

The use of the `init` and `shutdown` commands are the primary ways to shut down a system. Both commands perform a *clean shutdown* of the system, which means that all file system changes are written to the disk, and all system services, processes, and the operating system are terminated normally.

The use of a system's stop key sequence or turning a system off and then on are not clean shutdowns because system services are terminated abruptly. However, it is sometimes necessary to use these actions in emergency situations. For instructions on system recovery techniques, see Chapter 13 or Chapter 14.

The following table describes the various shutdown commands and provides recommendations for using them.

TABLE 12-1 Shutdown Commands

Command	Description	When To Use
<code>shutdown</code>	An executable shell script that calls the <code>init</code> program to shut down the system. The system is brought to run level S by default.	Recommended for servers running at run level 3 because users are notified of the impending shut down. Also notified are the systems that are mounting resources from the server that is being shut down.
<code>init</code>	An executable that kills all active processes and syncs the disks before changing run levels.	Recommended for standalone systems when other users will not be affected. Provides a faster system shutdown because users are not notified of the impending shutdown.
<code>reboot</code>	An executable that syncs the disks and passes boot instructions to the <code>uadmin</code> system call, which, in turn, stops the processor.	Not recommended. Use the <code>init</code> command instead.
<code>halt</code>	An executable that syncs the disks and stops the processor.	Not recommended because it doesn't execute the <code>/etc/rc0</code> script. This script stops all processes, syncs the disks, and unmounts any remaining file systems.

User Notification of System Down Time

When the `shutdown` command is initiated, a warning followed by a final shutdown message is broadcast to all users who are currently logged onto the system and all systems that are mounting resources from the affected system.

For this reason, the `shutdown` command is recommended over the `init` command when you need to shut down a server. When you use either command, you might want to give users more notice by sending them a mail message about any scheduled system shutdown.

Use the `who(1)` command to determine which users on the system need to be notified. This command is also useful for determining a system's current run level. See "How to Determine a System's Run Level" on page 156.

▼ How to Determine Who Is Logged in to a System

1. Log into the system to be shut down.
2. Display logged-in users.

```
$ who
```

Example—Determining Who Is Logged in to a System

The following example shows how to display who is logged in to the system.

```
$ who
holly  1      console      May  7 07:30
kryten pts/0 2      May  7 07:35      (starbug) 4
lister pts/1      May  7 07:40 3 (bluemidget)
```

1. Identifies the user name of the logged-in user.
2. Identifies the terminal line of the logged-in user.
3. Identifies the date and time that the user logged in.
4. (Optional) Identifies the host name if a user is logged in from a remote system.

▼ How to Shut Down a Server

Use this procedure when you need to shut down a server.

1. Become superuser.
2. Find out if users are logged in to the system.

```
# who
```

A list of all logged-in users is displayed. You might want to send mail or broadcast a message to let users know that the system is being shut down.

3. Shut down the system.

```
# shutdown -iinit-level -ggrace-period -y
```

<i>-iinit-level</i>	Brings the system to an init level that is different from the default of S. The choices are 0, 1, 2, 5, and 6.
<i>-ggrace-period</i>	Indicates a time (in seconds) before the system is shut down. The default is 60 seconds.
<i>-y</i>	Continues to shut down the system without intervention. Otherwise, you are prompted to continue the shutdown process after 60 seconds.

For more information, see `shutdown(1M)`.

4. If you are asked for confirmation, type **y**.

```
Do you want to continue? (y or n): y
```

If you used the `shutdown -y` command, you will not be prompted to continue.

5. Type the superuser password, if prompted.

```
Type Ctrl-d to proceed with normal startup,  
(or give root password for system maintenance): xxx
```

6. After you have finished the system administration tasks, press Control-D to return to the default system run level.

7. Use the following table to verify that the system is at the run level that you specified in the `shutdown` command.

Specified Run Level	SPARC System Prompt	x86 System Prompt
S (single-user level)	#	#
0 (power-down level)	ok or >	type any key to continue
Run level 3 (multiuser level with remote resources shared)	<i>hostname</i> console login:	<i>hostname</i> console login:

SPARC: Example—Bringing a Server to Run Level S

In the following example, the shutdown is used to bring a SPARC based system to run level S (single-user level) in 3 minutes.

```
# who
root      console      Dec 13 14:30
# shutdown -g180 -y

Shutdown started.      Thu Dec 13 14:30:32 MST 2001

Broadcast Message from root (console) on earth Thu Dec 13 14:30:33...
The system earth will be shut down in 3 minutes
.
.
Broadcast Message from root (console) on earth Thu Dec 13 14:30:33...
The system earth will be shut down in 30 seconds
.
.
INIT: New run level: S
The system is coming down for administration.  Please wait.
Unmounting remote filesystems: /vol nfs done.
Shutting down Solaris Management Console server on port 898.
Print services stopped.
Dec 13 14:34:00 earth syslogd: going down on signal 15
Killing user processes: done.

INIT: SINGLE USER MODE

Type control-d to proceed with normal startup,
(or give root password for system maintenance): xxx
Entering System Maintenance Mode ...
#
```

SPARC: Example—Bringing a Server to Run Level 0

In the following example, the shutdown command is used to bring a SPARC based system to run level 0 in 5 minutes without requiring additional confirmation.

```
# who
root      console      Dec 12 08:08
rimmer    pts/0      Dec 11 14:48    (starbug)
pmorph    pts/1      Dec 13 12:31    (bluemidget)
# shutdown -i0 -g300 -y
Shutdown started.      Thu Dec 13 14:51:39 MST 2001

Broadcast Message from root (console) on earth Thu Dec 13 14:51:39...
The system earth will be shut down in 5 minutes
.
.
.
```

```
Changing to init state 0 - please wait
#
INIT: New run level: 0
The system is coming down. Please wait.
System services are now being stopped.
.
.
.
The system is down.
syncing file systems... done
Program terminated
Type help for more information
ok
```

If you are bringing the system to run level 0 to turn off power to all devices, see “How to Turn Off Power to All Devices” on page 177.

SPARC: Example—Rebooting a Server to Run Level 3

In the following example, the shutdown command is used to reboot a SPARC based system to run level 3 in two minutes without requiring additional confirmation.

```
# who
root      console      Dec 12 08:08
rimmer    pts/0              Dec 11 14:48   (starbug)
pmorph    pts/1              Dec 13 12:31   (bluemidget)
# shutdown -i6 -g120 -y
Shutdown started.   Thu Dec 13 15:56:30

Broadcast Message from root (console) on earth Thu Dec 13 15:56:30...
The system earth will be shut down in 2 minutes
.
.
.
Changing to init state 6 - please wait
#
INIT: New run level: 6
The system is coming down. Please wait.
.
.
.
The system is down.
syncing file systems... done
rebooting...
.
.
.
earth console login:
```

Where to Go From Here

Regardless of why you shut down a system, you'll probably want to return to run level 3 where all file resources are available and users can log in. For instructions on bringing a system back to a multiuser level, see Chapter 13 or Chapter 14.

▼ How to Shut Down a Standalone System

Use this procedure when you need to shut down a standalone system.

1. **Become superuser.**

2. **Shut down the system.**

```
# init run-level
```

run-level identifies the new run level.

For more information, see `init(1M)`.

3. **Use the following table to verify that the system is at the run level that you specified in the `init` command.**

Specified Run Level	SPARC System Prompt	x86 System Prompt
S (single-user level)	#	#
2 (multiuser level)	#	#
0 (power-down level)	ok or >	type any key to continue
3 (multiuser level with NFS resources shared)	<i>hostname</i> console login:	<i>hostname</i> console login:

x86: Example—Bringing a Standalone System to Run Level 0

In the following example, the `init` command is used to bring an x86 based standalone system to the level where it is safe to turn off power.

```
# init 0
#
INIT: New run level: 0
The system is coming down. Please wait.
.
.
.
```

```
The system is down.
syncing file systems... [11] [10] [3] done
Type any key to continue
```

If you are bringing the system to run level 0 to turn off power to all devices, see “How to Turn Off Power to All Devices” on page 177.

SPARC: Example—Bringing a Standalone System to Run Level S

In the following example, the `init` is used to bring a SPARC based standalone system to run level S (single-user level).

```
# init s
#
INIT: New run level: S
The system is coming down for administration. Please wait.
Unmounting remote filesystems: /vol nfs done.
Print services stopped.
syslogd: going down on signal 15
Killing user processes: done.
INIT: SINGLE USER MODE

Type Ctrl-d to proceed with normal startup,
(or give root password for system maintenance): xxx
Entering System Maintenance Mode
#
```

Where to Go From Here

Regardless of why you shut down the system, you’ll probably want to return to run level 3 where all file resources are available and users can log in. For instructions on bringing a system back to a multiuser level, see Chapter 13 or Chapter 14.

Turning Off Power to All Devices

You need turn off power to all system devices is when you do the following:

- Replace or add hardware
- Move the system from one location to another
- Prepare for an expected power outage or natural disaster like an approaching electrical storm

System devices to power down include the CPU, the monitor, and external devices such as disks, tapes, and printers.

Before you turn off power to all system devices, you should shutdown the system cleanly, as described in the preceding sections.

▼ How to Turn Off Power to All Devices

1. **Select one of the following to shut down the system.**
 - a. **If shutting down a server, see “How to Shut Down a Server” on page 171.**
 - b. **If shutting down a standalone system, see “How to Shut Down a Standalone System” on page 175.**
2. **Turn off the power to all devices after the system is shutdown. If necessary, also unplug the power cables.**
3. **After power can be restored, use the following steps to turn on the system and devices.**
 - a. **Plug in the power cables.**
 - b. **Turn on the monitor.**
 - c. **Turn on disk drives, tape drives, and printers.**
 - d. **Turn on the CPU.**
The system is brought to run level 3.

SPARC: Booting a System (Tasks)

This chapter describes the procedures for using the OpenBoot™ PROM monitor and the procedures for booting a SPARC based system to different run levels.

For information on the procedures associated with booting a SPARC system, see “SPARC: Booting a System (Task Map)” on page 179.

For overview information about the boot process, see Chapter 10. To troubleshoot boot problems, see “What to Do If Rebooting Fails” in *System Administration Guide: Advanced Administration*.

For step-by-step instructions on booting an x86 based system, see Chapter 14.

SPARC: Booting a System (Task Map)

Task	Description	For Instructions
Use the Boot PROM	<p>The boot PROM is used to boot a system. You might need to do one of the following:</p> <p>Identify the PROM revision number.</p> <p>Identify devices on the system to boot from.</p>	<p>“SPARC: How to Find the PROM Revision for a System” on page 181</p> <p>“SPARC: How to Identify Devices on a System” on page 181</p>

Task	Description	For Instructions
Boot the system	<p>Change the default boot device when a new disk is added or when you need to change the system boot method.</p> <p>Select one of the following boot methods:</p> <p>Boot to run level 3 - Used after shutting down the system or performing some system hardware maintenance task.</p> <p>Boot to run level S - Used after performing some system maintenance task such as backing up a file system. At this level, only local file systems are mounted and users cannot log into the system.</p> <p>Boot interactively - Used after making temporary changes to a system file or the kernel for testing purposes.</p> <p>Boot from the network - Used to boot a system from the network. This method is used for booting a diskless client.</p> <p>Boot for recovery purposes - Used to boot the system when a damaged file or file system is preventing the system from booting. You might need to do one or both of the following to boot for recovery purposes:</p> <p>First, stop the system to attempt recovery.</p> <p>Boot to repair an important system file that is preventing the system from booting successfully.</p> <p>Boot kadb - Used to troubleshoot system problems.</p>	<p>“SPARC: How to Change the Default Boot Device” on page 183</p> <p>“SPARC: How to Boot a System to Run Level 3 (Multiuser Level)” on page 186</p> <p>“SPARC: How to Boot a System to Run Level S (Single-User Level)” on page 187</p> <p>“SPARC: How to Boot a System Interactively” on page 188</p> <p>“SPARC: How to Boot a System From the Network” on page 189</p> <p>“SPARC: How to Stop the System for Recovery Purposes” on page 190</p> <p>“SPARC: How to Boot a System for Recovery Purposes” on page 191</p> <p>“SPARC: How to Stop the System for Recovery Purposes” on page 190</p>

Task	Description	For Instructions
	Force a crash dump and reboot the system - Used to force a crash dump for troubleshooting purposes.	“SPARC: How to Force a Crash Dump and Reboot the System” on page 194

SPARC: Using the Boot PROM

System administrators typically use the PROM level to boot a system. Occasionally, however, you might need to change the way the system boots. For example, you might want to reset the device to boot from or run hardware diagnostics before you bring the system to a multiuser level.

You need to change the default boot device to do the following:

- Add a new drive to the system either permanently or temporarily
- Change the network boot strategy
- Temporarily boot a standalone system from the network

For a complete list of PROM commands, see `monitor(1M)` or `eeprom(1M)`.

SPARC: How to Find the PROM Revision for a System

Display a system’s PROM revision level with the `banner` command.

```
ok banner
Sun Ultra 5/10 UPA/PCI (UltraSPARC-IIi 333MHz), No Keyboard
OpenBoot 3.15, 128 MB memory installed, Serial #number.
Ethernet address number, Host ID: number.
```

Hardware configuration information, including the revision number of the PROM, is displayed. In this example, the PROM revision number is 3.15.

▼ SPARC: How to Identify Devices on a System

You might need to identify the devices on the system to figure out what are the appropriate devices to boot from.

Before you can safely use the `probe` commands to find out what devices are attached to the system, you need to do the following:

- Change the PROM `auto-boot?` parameter to false and

- Issue the `reset-all` command to clear system registers

You can the probe commands that are available on your system by using the sifting probe command, as follows:

```
ok sifting probe
```

If you run the probe commands without clearing the system registers, the following message is displayed:

```
ok probe-scsi  
This command may hang the system if a Stop-A or halt command  
has been executed. Please type reset-all to reset the system  
before executing this command.  
Do you wish to continue? (y/n) n
```

1. Change the PROM `auto-boot?` parameter to false.

```
ok setenv auto-boot? false
```

2. Clear the system's registers.

```
ok reset-all
```

3. Identify the devices on the system.

```
ok probe-device
```

4. (Optional) If you want the system to reboot after a power failure or after using the `reset` command, then change the `auto-boot?` parameter back to true.

```
ok setenv auto-boot? true  
auto-boot? = true
```

SPARC: Examples—Identifying the Devices on a System

The following example shows how to identify the devices connected to an Ultra10 system.

```
ok setenv auto-boot? false  
auto-boot? = false  
ok reset-all  
Resetting ...
```

```
Sun Ultra 5/10 UPA/PCI (UltraSPARC-IIi 333MHz), No Keyboard  
OpenBoot 3.15, 128 MB memory installed, Serial #10933339.  
Ethernet address 8:0:20:a6:d4:5b, Host ID: 80a6d45b.
```

```
ok probe-ide  
Device 0 ( Primary Master )  
ATA Model: ST34321A  
  
Device 1 ( Primary Slave )  
Not Present
```

```
Device 2 ( Secondary Master )
Removable ATAPI Model: CRD-8322B
```

```
Device 3 ( Secondary Slave )
Not Present
```

```
ok setenv auto-boot? true
auto-boot? = true
```

You can use the `devalias` command to identify the device aliases and the associated paths of devices that *might* be connected to the system.

```
ok devalias
screen /pci@1f,0/pci@1,1/SUNW,m64B@2
net /pci@1f,0/pci@1,1/network@1,1
cdrom /pci@1f,0/pci@1,1/ide@3/cdrom@2,0:f
disk /pci@1f,0/pci@1,1/ide@3/disk@0,0
disk3 /pci@1f,0/pci@1,1/ide@3/disk@3,0
disk2 /pci@1f,0/pci@1,1/ide@3/disk@2,0
disk1 /pci@1f,0/pci@1,1/ide@3/disk@1,0
disk0 /pci@1f,0/pci@1,1/ide@3/disk@0,0
ide /pci@1f,0/pci@1,1/ide@3
floppy /pci@1f,0/pci@1,1/ebus@1/fdthree
ttyb /pci@1f,0/pci@1,1/ebus@1/se:b
ttya /pci@1f,0/pci@1,1/ebus@1/se:a
keyboard! /pci@1f,0/pci@1,1/ebus@1/su@14,3083f8:forcemode
keyboard /pci@1f,0/pci@1,1/ebus@1/su@14,3083f8
mouse /pci@1f,0/pci@1,1/ebus@1/su@14,3062f8
name aliases
```

▼ SPARC: How to Change the Default Boot Device

You might need to identify the devices on the system before you can change the default boot device to some other device. For information on identifying devices on the system, see “SPARC: How to Identify Devices on a System” on page 181.

1. Become superuser.

2. Change to run level 0.

```
# init 0
```

The `ok` PROM prompt is displayed.

For more information, see `init(1M)`.

3. Change the value of the `boot-device` parameter.

```
ok setenv boot-device device [n]
```

<code>boot-device</code>	Identifies the parameter for setting the device from which to boot.
<code>device[n]</code>	Identifies the <code>boot-device</code> value such as a disk or the network. The <i>n</i> can be specified as the <i>disk number</i> .

Use one of the probe commands if you need help with identifying the disk number.

4. Verify that the default boot device is changed.

```
ok printenv boot-device
```

5. Save the new boot-device value.

```
ok reset
```

The new `boot-device` value is written to the PROM.

SPARC: Examples—Changing the Default Boot Device

In this example, the default boot device is set to disk.

```
# init 0
#
INIT: New run level: 0
.
.
.
The system is down.
syncing file systems... done
Program terminated
ok setenv boot-device disk
boot-device =          disk
ok printenv boot-device
boot-device            disk                disk
ok reset
Sun Ultra 5/10 UPA/PCI (UltraSPARC-IIi 333MHz), No Keyboard
OpenBoot 3.15, 128 MB memory installed, Serial #number.
Ethernet address number, Host ID: number.

Boot device: disk File and args:
SunOS Release 5.9 Version 64-bit
.
.
.
pluto console login:
```

In this example, the default boot device is set to the network.

```
# init 0
#
INIT: New run level: 0
```



```
.
.
.
The system is down.
syncing file systems... done
Program terminated
ok setenv boot-device net
boot-device =          net
ok printenv boot-device
boot-device            net                disk
ok reset
Sun Ultra 5/10 UPA/PCI (UltraSPARC-IIi 333MHz), No Keyboard
OpenBoot 3.15, 128 MB memory installed, Serial #number.
Ethernet address number, Host ID: number.
```

```
Boot device: net  File and args:
.
.
.
pluto console login:
```

SPARC: How to Reset the System

Run the `reset` command from the `ok` prompt.

```
ok reset
```

This self-test program, which runs diagnostic tests on the hardware, is executed and the system is rebooted.

SPARC: Booting a System

If a system is turned off, turning it on starts the multiuser boot sequence. The following procedures show how to boot to different run levels from the `ok` PROM prompt. These procedures assume that the system has been cleanly shut down, unless stated otherwise.

Use the `who -r` command to verify that the system is brought to the specified run level. For a description of run levels, see Chapter 11.

▼ SPARC: How to Boot a System to Run Level 3 (Multiuser Level)

Use this procedure to boot a system that is currently at run level 0 to run level 3.

1. Boot the system to run level 3.

```
ok boot
```

The automatic boot procedure displays a series of startup messages, and brings the system to run level 3.

For more information, see `boot(1M)`.

2. Verify that the system has booted to run level 3.

The login prompt is displayed when the boot process has finished successfully.

```
hostname console login:
```

SPARC: Example—Booting a System to Run Level 3 (Multiuser Level)

The following example displays the messages from booting a system to run level 3.

```
ok boot
Sun Ultra 5/10 UPA/PCI (UltraSPARC-III 333MHz)
OpenBoot 3.15, 128 MB memory installed, Serial #number.
Ethernet address number, Host ID: number.

Rebooting with command: boot
Boot device: disk:a File and args:
SunOS Release 5.9 Version Generic 64-bit
Copyright (c) 1983-2002 by Sun Microsystems, Inc.
configuring IPv4 interfaces: hme0.
Hostname: starbug
The system is coming up. Please wait.
checking ufs filesystems
/dev/rdsk/c0t0d0s7: is clean.
/dev/rdsk/c0t0d0s4: is clean.
NIS domainname is Solar.COM
starting rpc services: rpcbind keyser vpbind done.
Setting netmask of hme0 to 255.255.255.0
Setting default IPv4 interface for multicast: add net 224.0/4:
gateway starbug
syslog service starting.
Print services started.
volume management starting.
The system is ready.

starbug console login:
```

▼ SPARC: How to Boot a System to Run Level S (Single-User Level)

Use this procedure to boot a system that is currently at run level 0 to run level S.

1. Boot the system to run level S.

```
ok boot -s
```

2. Type the superuser password when the following message is displayed.

```
INIT: SINGLE USER MODE
Type Ctrl-d to proceed with normal startup,

(or give root password for system maintenance): xxx
```

3. Verify that the system is at run level S.

```
# who -r
.          run-level S  Jun 10 15:27      3      0
```

4. To bring the system up to multiuser state after you completed the system maintenance task, press Control-D.

SPARC: Example—Booting a System to Run Level S (Single-User Level)

The following example displays the messages from booting a system to run level S.

```
ok boot -s
.
.
.
SunOS Release 5.9 Version Generic 64-bit
Copyright (c) 1983-2002 by Sun Microsystems, Inc.
configuring IPv4 interfaces: le0.
Hostname: earth

INIT: SINGLE USER MODE

Type control-d to proceed with normal startup,
(or give root password for system maintenance): xxx
Sun Microsystems Inc.  SunOS 5.9  Generic May 2002
# who -r
.          run-level S  Jul 14 11:37      3      0  ?
(Perform some maintenance task)
# Press Control-D
```

▼ SPARC: How to Boot a System Interactively

Use this procedure to boot a system and you need to specify an alternate kernel or `/etc/system` file.

1. Boot the system interactively.

```
ok boot -a
```

2. Answer the system prompts as described in the following table.

System Prompt	Action
Enter filename [kernel/[sparcv9]/unix]:	Provide the name of kernel to use for booting. Or, press Return to use the default kernel.
Enter default directory for modules [/platform/'uname -i'/kernel /platform/'uname -m'/kernel /kernel /usr/kernel]:	Provide an alternate path for the modules directory. Or, press Return to use the default kernel modules directory.
Name of system file [etc/system]:	Provide the name of an alternate system file and press Return. Type <code>/dev/null</code> if your <code>/etc/system</code> file has been damaged. Or, press Return to use the default <code>etc/system</code> file.
root filesystem type [ufs]:	Press Return to use the default root (<code>/</code>) file system. Type UFS for local disk booting, or NFS for network booting.
Enter physical name of root device [<i>physical_device_name</i>]:	Provide an alternate device name and press Return. Or, press Return to use the default physical name of the root device.

3. If you are not prompted to answer the questions in the preceding table, verify that you typed the `boot -a` command correctly.

SPARC: Example—Booting a System Interactively

In the following example, the default choices (shown in square brackets `[]`) are accepted.

```
ok boot -a
.
.
.
Rebooting with command: boot -a
Boot device: /pci@1f,0/pci@1,1/ide@3/disk@0,0:a File and args: -a
Enter filename [kernel/sparcv9/unix]: Press Return
```

```

Enter default directory for modules [/platform/SUNW,Ultra-5_10/kernel
/platform/sun4u/kernel /kernel /usr/kernel]: Press Return
Name of system file [etc/system]: Press Return
SunOS Release 5.9 Version Generic 64-bit
Copyright (c) 1983-2002 by Sun Microsystems, Inc.
root filesystem type [ufs]: Press Return
Enter physical name of root device
[/pci@1f,0/pci@1,1/ide@3/disk@0,0:a]: Press Return
configuring IPv4 interfaces: hme0.
Hostname: starbug
The system is coming up. Please wait.
checking ufs filesystems
.
.
.
The system is ready.
starbug console login:

```

▼ SPARC: How to Boot a System From the Network

Any system can boot from the network if there is a boot server available. You might want to boot a standalone system from the network temporarily if the system cannot boot from the local disk. For information on changing or resetting the default boot device, see “SPARC: How to Change the Default Boot Device” on page 183.

Two network configuration boot strategies are available on sun4u systems:

- RARP (Reverse Address Resolution Protocol and ONC+ RPC Bootparams Protocol)
- DHCP (Dynamic Host Configuration Protocol)

The default network boot strategy is set to RARP. You can use either strategy depending on whether a RARP boot server or a DHCP boot server is available on your network.

Note – Sun Ultra systems must have PROM version 3.25.*nnn* or later to use the DHCP network boot strategy. For information on finding your PROM version, see “SPARC: How to Find the PROM Revision for a System” on page 181.

If both methods are available, you can specify which service to use in the `boot` command temporarily. Or, you can save the network boot strategy across system reboots at the PROM level, by setting up an NVRAM alias. The following example uses the `nvalias` command to set up a network device alias for booting DHCP by default on a Sun Ultra 10 system.

```
ok nvalias net /pci@1f,4000/network@1,1:dhcp
```

This alias means that when you type `boot net`, the system boots by using the DHCP network boot strategy.



Caution – You should not use the `nvalias` command to modify the `NVRAMRC` file unless you are very familiar with the syntax of this command and the `nvunalias` command. For information on using these commands, see the *OpenBoot 3.x Command Reference Manual*.

1. If necessary, shut down the system.

2. Determine the method for booting from the network and select one of the following:

You must have already set up a RARP or DHCP boot server in your network to use either method to boot successfully.

a. Boot the system from the network by using the DHCP method.

```
ok boot net[:dhcp]
```

If you have changed the PROM setting to boot DHCP by default, as in the preceding `nvalias` example, you only have to specify `boot net`.

b. Boot the system from the network by using the RARP method.

```
ok boot net[:rarp]
```

Since RARP is the default network boot strategy, you only have to specify `boot net : rarp` if you have changed the PROM value to boot DHCP.

▼ SPARC: How to Stop the System for Recovery Purposes

1. Type the stop key sequence for your system.

The monitor displays the `ok` PROM prompt.

```
ok
```

The specific stop key sequence depends on your keyboard type. For example, you can press Stop-A or L1-A. On terminals, press the Break key.

2. Synchronize the file systems.

```
ok sync
```

3. When you see the `syncing file systems...` message, press the stop key sequence for your system again.

4. Type the appropriate boot command to start the boot process.

For more information, see `boot(1M)`.

5. Verify that the system is booted to the specified run level.

```
# who -r
.          run-level 3  May  2 07:39    3      0  S
```

SPARC: Example—Stopping the System for Recovery Purposes

```
Press Stop-A
ok sync
syncing file systems...
Press Stop-A
ok boot
```

▼ SPARC: How to Boot a System for Recovery Purposes

Use this procedure when an important file, such as `/etc/passwd`, has an invalid entry and causes the boot process to fail.

Substitute the device name of the file system to be repaired for the `devicename` variable in the following procedures. If you need help identifying a system’s device names, refer to Chapter 30.

1. Stop the system by using the system’s stop key sequence.

Use the stop sequence for your system if you don’t know the root password or if you can’t log in to the system. For more information, see “SPARC: How to Stop the System for Recovery Purposes” on page 190.

2. Follow the instructions in the table, depending on whether you are booting from the Solaris installation CD or DVD or from the network.

Boot Type	Action
Solaris installation CD or DVD	1. Insert the Solaris installation media into the drive. 2. Boot from the installation media in single-user mode: ok boot cdrom -s
The network if an installation server or remote CD or DVD drive are available	Use the following command: ok boot net -s

3. Mount the file system that contains the file with an invalid entry.

```
# mount /dev/dsk/device-name /a
```

4. Change to the newly mounted file system.

```
# cd /a/file-system
```

5. Set the terminal type.

```
# TERM=sun
# export TERM
```

6. Remove the invalid entry from the file by using an editor.

```
# vi filename
```

7. Change to the root (/) directory.

```
# cd /
```

8. Unmount the /a directory.

```
# umount /a
```

9. Reboot the system.

```
# init 6
```

10. Verify that the system booted to run level 3.

The login prompt is displayed when the boot process has finished successfully.

```
hostname console login:
```

SPARC: Example—Booting a System for Recovery Purposes (Damaged Password File)

The following example shows how to repair an important system file (in this case, /etc/passwd) after booting from a local CD-ROM.

```
ok boot cdrom -s
# mount /dev/dsk/c0t3d0s0 /a
# cd /a/etc
# TERM=vt100
# export TERM
# vi passwd
(Remove invalid entry)
# cd /
# umount /a
# init 6
```

SPARC: Example—Booting a System if You Forgot Root Password

The following example shows how to recover when you forget the root password by booting from the network. This example assumes that the network boot server is already available. Be sure to apply a new root password after the system has rebooted.

```
ok boot net -s
# mount /dev/dsk/c0t3d0s0 /a
# cd /a/etc
# TERM=vt100
# export TERM
# vi shadow
(Remove root's encrypted password string)
# cd /
# umount /a
# init 6
```

▼ SPARC: How to Boot the System With the Kernel Debugger (kadb)

1. If you need to stop the system, type the stop key sequence for your system.

The specific stop key sequence depends on your keyboard type. For example, you can press `Stop-A` or `L1-A`. On terminals, press the `Break` key.

The PROM displays the `ok` prompt.

2. Synchronize the file systems and write the crash dump.

```
> n
ok sync
```

3. When you see the `syncing file systems...` message, press the stop key sequence for your system again.

4. Boot the system with the kernel debugger.

```
ok boot kadb
```

5. Check `kadb` boot messages to verify that the system has booted with the kernel debugger.

```
Rebooting with command: kadb
Boot device: /iommu/sbus/espdma@4,800000/esp@4,8800000/sd@3,0
.
.
.
```

SPARC: Example—Booting the System With the Kernel Debugger (kadb)

```
Press Stop-A
ok sync
syncing file systems...
Press Stop-A
ok boot kadb
```

SPARC: Forcing a Crash Dump and Rebooting the System

Forcing a crash dump and rebooting the system is sometimes necessary for troubleshooting purposes. The `savecore` feature is enabled by default.

For more information on system crash dumps, see “Managing System Crash Information (Tasks)” in *System Administration Guide: Advanced Administration*.

▼ SPARC: How to Force a Crash Dump and Reboot the System

Use this procedure to force a crash dump and reboot the system when the `savecore` feature is enabled.

1. Type the stop key sequence for your system.

The specific stop key sequence depends on your keyboard type. For example, you can press `Stop-a` or `L1-a`. On terminals, press the `Break` key.

The PROM displays the `ok` prompt.

2. Synchronize the file systems and write the crash dump.

```
> n
ok sync
```

After the crash dump is written to disk, the system will continue to reboot.

3. Verify the system boots to run level 3.

The login prompt is displayed when the boot process has finished successfully.

```
hostname console login:
```

SPARC: Example—Forcing a Crash Dump and Rebooting the System

Press Stop-A
ok **sync**

x86: Booting a System (Tasks)

This chapter describes the procedures for booting an x86 based system.

For information on the procedures associated with booting an x86 system, see “x86: Booting a System (Task Map)” on page 197.

For overview information about the boot process, see Chapter 10.

For step-by-step instructions on booting a SPARC based system, see Chapter 13.

x86: Booting a System (Task Map)

Task	Description	For Instructions
Boot the Solaris Device Configuration Assistant	Used after changing the hardware configuration of the system. This utility enables you to boot the Solaris system from a different boot device, configure new or misconfigured hardware, or perform other device-related or boot-related tasks.	“x86: How to Boot the Solaris Device Configuration Assistant” on page 199
Boot the system	Select one of the following boot methods: Boot to run level 3 – Used after shutting down the system or performing some system hardware maintenance task.	“x86: How to Boot a System to Run Level 3 (Multiuser Level)” on page 199

Task	Description	For Instructions
	<p>Boot to run level S - Used after performing some system maintenance task such as backing up a file system.</p> <p>Boot interactively – Used after making temporary changes to a system file or the kernel for testing purposes.</p> <p>Boot from the network - Used to boot a system from the network. This method is used for booting a diskless client.</p> <p>Boot for recovery purposes - Used to boot the system when a damaged file is preventing the system from booting. You might need to do one or both of the following to boot for recovery purposes:</p> <p>First, stop the system to attempt recovery.</p> <p>Boot to repair an important system file that is preventing the system from booting successfully.</p> <p>Boot <code>kadb</code> – Used to troubleshoot system problems.</p> <p>Force a crash dump and reboot the system - Used to force a crash dump for troubleshooting purposes.</p>	<p>“x86: How to Boot a System to Run Level S (Single-User Level)” on page 200</p> <p>“x86: How to Boot a System Interactively” on page 201</p> <p>“x86: How to Boot a System From the Network” on page 203</p> <p>“x86: How to Stop a System for Recovery Purposes” on page 204</p> <p>“x86: How to Boot a System for Recovery Purposes” on page 204</p> <p>“x86: How to Boot a System With the Kernel Debugger (<code>kadb</code>)” on page 209</p> <p>“x86: Forcing a Crash Dump and Rebooting the System” on page 210</p>

x86: Booting the Solaris Device Configuration Assistant

The Device Configuration Assistant (Solaris x86 Platform Edition) is a program that enables you to perform various hardware configuration and booting tasks. You can access the Solaris Device Configuration Assistant from either of the following:

- Solaris boot diskette

- Solaris Installation CD or DVD

In the procedures in this chapter, you might be requested to insert the Solaris Device Configuration Assistant boot diskette to boot the Configuration Assistant. If your system's BIOS supports booting from the CD or DVD, you can, instead, insert the Solaris installation CD or DVD to boot the Configuration Assistant.

▼ x86: How to Boot the Solaris Device Configuration Assistant

1. **Insert the Solaris Device Configuration Boot Diskette or the Solaris Installation CD or DVD in the appropriate drive.**
2. **If the system displays the `Type any key to continue` prompt, press any key to reboot the system.**

You can also use the reset button at this prompt. If the system is shut down, turn the system on with the power switch.

The first menu of the Configuration Assistant is displayed after a few minutes.

x86: Booting a System

The following procedures use the reset button to restart the system. If your system does not have a reset button, use the power switch to restart the system. You might be able to press the Ctrl-Alt-Del keys to interrupt system operation, depending upon the state of the system.

▼ x86: How to Boot a System to Run Level 3 (Multiuser Level)

Use this procedure to boot a system (that is currently at run level 0) to run level 3.

1. **If the system displays the `Type any key to continue` prompt, press any key to reboot the system.**

You can also use the reset button at this prompt. If the system is shut down, turn the system on with the power switch.

The Current Boot Parameters menu is displayed after a few minutes.

2. **Type `b` to boot the system to run level 3. Press Enter.**

If you do not make a selection within five seconds, the system is automatically booted to run level 3.

3. Verify that the system has booted to run level 3.

The login prompt is displayed when the boot process has finished successfully.

hostname console login:

x86: Example—Booting a System to Run Level 3 (Multiuser Level)

```
Type any key to continue
.
.
.
<<< Current Boot Parameters >>>
Boot path: /pci@0,0/pci-ide@7,1/ide@0/cmdk@0,0:a
Boot args:
Type    b [file-name] [boot-flags] <ENTER>    to boot with options
or      i <ENTER>                               to enter boot interpreter
or      <ENTER>                                to boot with defaults

<<< timeout in 5 seconds >>>

Select (b)oot or (i)nterpreter: b
.
.
.
venus console login:
```

▼ x86: How to Boot a System to Run Level S (Single-User Level)

Use this procedure to boot a system (that is currently at run level 0) to run level S.

1. If the system displays the Type any key to continue prompt, press any key to reboot the system.

You can also use the reset button at this prompt. If the system is shut down, turn the system on with the power switch.

The Current Boot Parameters menu is displayed after a few minutes.

2. Type b -s to boot the system to run level S. Press Enter.

If you do not make a selection within five seconds, the system is automatically booted to run level 3.

3. Type the superuser password, if prompted.

4. Verify that the system is at run level S by using the `who -r` command.

```
# who -r
.          run-level S  Jul 19 14:37    S      0  3
```

5. Perform the maintenance task that required the run level change to S.

6. Press Control-D to bring the system back to run level 3.

x86: Example—Booting a System to Run Level S (Single-User Level)

Type any key to continue

```
.
.
.

<<< Current Boot Parameters >>>
Boot path: /pci@0,0/pci-ide@7,1/ide@0/cmdk@0,0:a
Boot args:
Type      b [file-name] [boot-flags] <ENTER>    to boot with options
or        i <ENTER>                             to enter boot interpreter
or        <ENTER>                               to boot with defaults
```

<<< timeout in 5 seconds >>>

Select (b)oot or (i)nterpreter: **b -s**

```
.
.
.
INIT: SINGLE USER MODE
```

Type Ctrl-d to proceed with normal startup,
(or give root password for system maintenance): **xxx**
Entering System Maintenance Mode

```
.
.
.
# who -r
.          run-level S  Jul 19 14:37    S      0  3
(Perform some maintenance task)
# Press Control-D
```

▼ x86: How to Boot a System Interactively

Use this procedure to boot a system and you need to specify an alternate kernel or `/etc/system` file.

1. If the system displays the **Type any key to continue** prompt, press any key to reboot the system.

You can also use the reset button at this prompt. If the system is shut down, turn the system on with the power switch.

The Primary Boot Subsystem menu is displayed after a few minutes.

2. Select the Solaris partition (if not marked as active) from the list and press Enter.

If you do not make a selection within five seconds, the active boot partition is selected automatically.

The Current Boot Parameters menu is displayed after a few minutes.

3. Type `b -a` to boot the system interactively. Press Enter.

If you do not make a selection within five seconds, the system is automatically booted to run level 3.

4. Answer the system prompts as described in the following table.

System Prompt	Action
Enter default directory for modules: [/platform/i86pc/kernel /kernel /usr/kernel]:	Provide an alternate path for the modules directory and press Enter. Or, press Enter to use the default modules directory path.
Name of system file [etc/system]:	Provide the name of an alternate system file and press Enter. Or, press Enter to use the default /etc/system file. Type /dev/null if your /etc/system file has been damaged.
root filesystem type [ufs]:	Press Enter to use the default root (/) file system. Type: UFS for local disk booting, or NFS for network booting.
Enter physical name of root device [physical_device_name]:	Provide an alternate device name and press Enter. Or, press Enter to use the default physical name of the root device bootpath.

x86: Example—Booting a System Interactively

In the following example, the default choices (shown in square brackets []) are accepted.

```
Type any key to continue
```

```
.  
.  
.
```

```
<<< Current Boot Parameters >>>
```

```
Boot path: /pci@0,0/pci-ide@7,1/ide@0/cmdk@0,0:a
```

```
Boot args:
```

```
Type      b [file-name] [boot-flags] <ENTER>      to boot with options  
or        i <ENTER>                                to enter boot interpreter
```

or <ENTER> to boot with defaults

```
<<< timeout in 5 seconds >>>>
Select (b)oot or (i)nterpreter: b -a
Enter default directory for modules [/platform/i86pc/kernel /kernel
/usr/kernel]: Press Enter
Name of system file [etc/system]: Press Enter
SunOS Release 5.9 Version Generic 32-bit
Copyright (c) 1983-2002 by Sun Microsystems, Inc.
root filesystem type [ufs]: Press Enter
Enter physical name of root device
[/pci@0,0/pci-ide@7,1/ide@0/cmdk@0,0:a]: Press Enter
configuring IPv4 interfaces: dnet0.
Hostname: venus
(fsck messages)
The system is coming up. Please wait
(More messages)
venus console login:
```

▼ x86: How to Boot a System From the Network

Any system can boot from the network if there is a boot server available. You might want to boot a standalone system from the network temporarily if the system cannot boot from the local disk.

If the system is capable of a PXE network boot, you might want to boot the system directly from the network without using either the Configuration Assistant boot diskette or the installation CD or DVD.

The menu, Set Network Configuration Strategy, on the Configuration Assistant's Boot Tasks Menu, enables you to select the appropriate boot strategy.

1. Determine whether you want to boot from the network by using the RARP/bootparams method or the DHCP method.

There are two network configuration strategies to choose from, RARP (Reverse Address Resolution Protocol) or DHCP (Dynamic Host Configuration Protocol). The default network boot strategy is set to RARP. You can use either strategy depending on whether a RARP boot server or a DHCP boot server is available on your network.

The PXE network boot is available only with DHCP.

2. Insert the Configuration Assistant boot diskette or the installation CD or DVD that you wish to boot from.

Or, use the system or network adapter BIOS configuration program to enable the PXE network boot.

3. If the system displays the Type any key to continue prompt, press any key to reboot the system.

You can also use the reset button at this prompt. If the system is shut down, turn the system on with the power switch.

The Solaris Device Configuration Assistant screen is displayed.

4. **Press the F2 key (F2_Continue) to scan for devices.**
Device identification is performed and the Identified Devices screen is displayed.
5. **Press the F2 key (F2_Continue) to load drivers.**
Bootable drivers are loaded.
The Boot Solaris menu is displayed.
6. **Press the F4 key (F4_Boot Tasks).**
7. **Select Set Network Configuration Strategy and press the F2 key (F2_Continue).**
8. **Select either RARP or DHCP and press the F2 key (F2_Continue).**
A screen that confirms your new network boot strategy appears.
Your network boot strategy selection is saved as the default network boot method for the next time this diskette is used for booting.
9. **Press F3_Back to return to the Boot Solaris menu.**
10. **Select NET as the boot device. Then, press F2_Continue to boot the network device.**
The Solaris boot option screen is displayed.

▼ x86: How to Stop a System for Recovery Purposes

1. **Stop the system by using one of the following commands, if possible:**
 - If the system is running, become superuser and type `init 0` to stop the system. After the `Type any key to continue` prompt appears, press any key to reboot the system.
 - If the system is running, become superuser and type `init 6` to reboot the system.
2. **If the system doesn't respond to any input from the mouse or keyboard, press the reset key, if it exists, to reboot the system. Or, you can use the power switch to reboot the system.**

▼ x86: How to Boot a System for Recovery Purposes

Follow these steps to boot the system to repair a critical system resource. The example shows you how to boot from a Solaris Installation CD or from the network, mount the root (/) file system on the disk, and repair the `/etc/passwd` file.

Substitute the device name of the file system to be repaired for the *devicename* variable in the following procedure. If you need help with identifying a system's device names, refer to Chapter 30.

1. Stop the system first by using the system stop key sequence.

Use the stop sequence for your system if you don't know the root password or if you can't log in to the system. For more information, see "x86: How to Stop a System for Recovery Purposes" on page 204.

2. Boot from the Solaris installation CD or DVD (or from the network) to single-user mode.

a. Insert the Configuration Assistant boot diskette or the installation CD or DVD that you wish to boot from.

b. If the system displays the Type any key to continue prompt, press any key to reboot the system.

You can also use the reset button at this prompt. If the system is shut down, turn the system on with the power switch.

The Solaris Device Configuration Assistant screen is displayed.

c. Press the F2 key (F2_Continue).

Device identification is performed and the Identified Devices screen is displayed.

d. Press the F2 key (F2_Continue).

Bootable drivers are loaded.

The Boot Solaris menu is displayed.

e. Select the CD-ROM drive or network device. Then press the F2 key (F2_Continue).

The Current Boot Parameters menu is displayed.

f. Type `b -s` at the prompt. Press Enter.

After a few minutes, the single-user mode # prompt is displayed.

3. Mount the root (/) file system that contains the invalid `passwd` file.

```
# mount /dev/dsk/devicename /a
```

4. Change to the newly mounted `etc` directory.

```
# cd /a/etc
```

5. Make the necessary change to the file by using an editor.

```
# vi filename
```

6. Change to the root (/) directory.

```
# cd /
```

7. Unmount the /a directory.

```
# umount /a
```

8. Reboot the system.

```
# init 6
```

9. Verify that the system has booted to run level 3.

The login prompt is displayed when the boot process has finished successfully.

```
hostname console login:
```

x86: Example—Booting a System for Recovery Purposes

The following example shows how to repair the `/etc/passwd` file after booting from a local CD-ROM.

Type any key to continue

```
SunOS Secondary Boot version 3.00
```

```
Solaris Intel Platform Edition Booting System
```

```
Running Configuration Assistant...
```

```
Autobooting from Boot path: /pci@0,0/pci-ide@7,1/ide@0/cmdk@0,0:a
```

If the system hardware has changed, or to boot from a different device, interrupt the autoboot process by pressing ESC.

Press ESCape to interrupt autoboot in 5 seconds.

```
.  
. .  
.
```

```
Boot Solaris
```

Select one of the identified devices to boot the Solaris kernel and choose Continue.

To perform optional features, such as modifying the autoboot and property settings, choose Boot Tasks.

An asterisk (*) indicates the current default boot device.

> To make a selection use the arrow keys, and press Enter to mark it [X].

```
[ ] NET : DEC 21142/21143 Fast Ethernet
```

```
on Board PCI at Dev 3
```

```
[ ] DISK: (*) Target 0, QUANTUM FIREBALL1280A
```

```
on Bus Mastering IDE controller on Board PCI at Dev 7, Func 1
```

```

[ ] DISK: Target 1:ST5660A
on Bus Mastering IDE controller on Board PCI at Dev 7, Func 1
[ ] DISK: Target 0:Maxtor 9 0680D4
on Bus Mastering IDE controller on Board PCI at Dev 7, Func 1
[X] CD : Target 1:TOSHIBA CD-ROM XM-5602B 1546
on Bus Mastering IDE controller on Board PCI at Dev 7, Func 1

```

```

F2_Continue  F3_Back  F4_Boot Tasks  F6_Help
.
.
.

```

```

<<< Current Boot Parameters >>>
Boot path: /pci@0,0/pci-ide@7,1/ide@0/cmdk@0,0:a
Boot args: kernel/unix -r

```

Select the type of installation you want to perform:

```

1 Solaris Interactive
2 Custom JumpStart
3 Solaris Web Start

```

Enter the number of your choice followed by <ENTER> the key.

If you enter anything else, or if you wait for 30 seconds, an interactive installation will be started.

Select type of installation: **b -s**

```

.
.
.
# mount /dev/dsk/c0t0d0s0 /a
.
.
.
# cd /a/etc
# vi passwd
(Remove invalid entry)
# cd /
# umount /a
# init 6

```

x86: Example—Booting a System if You Forgot Root Password

The following example shows how to recover when you forget the root password by booting from the network. This example assumes that the boot server is already available. Be sure to apply a new root password after the system has rebooted.

Type any key to continue

SunOS Secondary Boot version 3.00

Solaris Intel Platform Edition Booting System

Running Configuration Assistant...

Autobooting from Boot path: /pci@0,0/pci-ide@7,1/ide@0/cmdk@0,0:a

If the system hardware has changed, or to boot from a different device, interrupt the autoboot process by pressing ESC.

Press ESCape to interrupt autoboot in 5 seconds.

.
.
.

Boot Solaris

Select one of the identified devices to boot the Solaris kernel and choose Continue.

To perform optional features, such as modifying the autoboot and property settings, choose Boot Tasks.

An asterisk (*) indicates the current default boot device.

> To make a selection use the arrow keys, and press Enter to mark it [X].

```
[X] NET : DEC 21142/21143 Fast Ethernet
on Board PCI at Dev 3
[ ] DISK: (*) Target 0, QUANTUM FIREBALL1280A
on Bus Mastering IDE controller on Board PCI at Dev 7, Func 1
[ ] DISK: Target 1:ST5660A
on Bus Mastering IDE controller on Board PCI at Dev 7, Func 1
[ ] DISK: Target 0:Maxtor 9 0680D4
on Bus Mastering IDE controller on Board PCI at Dev 7, Func 1
[ ] CD : Target 1:TOSHIBA CD-ROM XM-5602B 1546
on Bus Mastering IDE controller on Board PCI at Dev 7, Func 1
```

F2_Continue F3_Back F4_Boot Tasks F6_Help

.
.
.

<<< Current Boot Parameters >>>

Boot path: /pci@0,0/pci-ide@7,1/ide@0/cmdk@0,0:a

Boot args: kernel/unix -r

Select the type of installation you want to perform:

1 Solaris Interactive
2 Custom JumpStart
3 Solaris Web Start

Enter the number of your choice followed by <ENTER> the key.

If you enter anything else, or if you wait for 30 seconds, an interactive installation will be started.

```

Select type of installation:  b -s
.
.
.
# mount /dev/dsk/c0t0d0s0 /a
.
.
.
# cd /a/etc
# vi shadow
(Remove root's encrypted password string)
# cd /
# umount /a
# init 6

```

▼ x86: How to Boot a System With the Kernel Debugger (kadb)

1. **If the system displays the Type any key to continue prompt, press any key to reboot the system.**

You can also use the reset button at this prompt.

If the system is shut down, turn the system on with the power switch.

2. **Type b kadb to boot the kernel debugger. Press Enter.**

If you do not make a selection within five seconds, the system is automatically booted to run level 3.

3. **Verify that the system has booted to run level 3.**

The login prompt is displayed when the boot process has finished successfully.

```
hostname console login:
```

4. **Verify that you can access the kernel debugger by pressing F1-A.**

The kadb [0] : prompt is displayed when you enter the kernel debugger.

x86: Example—Booting a System With the Kernel Debugger (kadb)

```

Type any key to continue
.
.
.
<<< Current Boot Parameters >>>
Boot path: /pci@0,0/pci-ide@7,1/ide@0/cmdk@0,0:a
Boot args:
Type    b [file-name] [boot-flags] <ENTER>    to boot with options

```

```
or      i <ENTER>          to enter boot interpreter
or      <ENTER>          to boot with defaults

        <<< timeout in 5 seconds >>>

Select (b)oot or (i)nterpreter: b kadb
      .
      .
      .
naboo console login: (Enter login and password)
(Press F1-A to verify that you can access the kernel debugger)
```

x86: Forcing a Crash Dump and Rebooting the System

Forcing a crash dump and rebooting the system is sometimes necessary for troubleshooting purposes. The `savecore` feature is enabled by default.

For more information on system crash dumps, see “Managing System Crash Information (Tasks)” in *System Administration Guide: Advanced Administration*.

▼ x86: How to Force a Crash Dump and Reboot the System

The system must be booted with the kernel debugger option, `kadb`, to get to the `kadb [0] :` prompt and to enable you to force the crash dump.

Note – You must be in text mode to enter the kernel debugger (`kadb`). So, first exit any window system.

1. Press F1–A.

```
kadb [0] :
The kadb [0] : prompt is displayed.
```

2. Type the following commands at the `kadb [0] :` prompt.

```
Press <F1-a>
kadb [0] : vfs_syncall/W ffffffff
kadb [0] : 0>eip
kadb [0] : :c
```

```
kadb[0] : :c
```

```
kadb[0] : :c
```

After you type the first `:c`, the system panics, so you need to type `:c` again. The system panics again, so type `:c` a third time to force the crash dump and reboot the system.

After the crash dump is written to disk, the system continues to reboot.

3. **Verify that the system has rebooted by logging in at the console login prompt.**

The Boot Process (Reference)

This chapter describes the firmware used for booting SPARC based and x86 based systems. This chapter also provides an overview of the boot process on each platform.

This is a list of the reference information in this chapter.

- “SPARC: The Boot PROM” on page 213
- “SPARC: The Boot Process” on page 214
- “x86: The PC BIOS” on page 214
- “x86: Boot Subsystems” on page 215
- “x86: The Boot Process” on page 220

For step-by-step instructions on booting a system, see Chapter 13 or Chapter 14.

SPARC: The Boot PROM

Each SPARC based system has a PROM (programmable read-only memory) chip with a program called the *monitor*. The monitor controls the operation of the system before the Solaris kernel is available. When a system is turned on, the monitor runs a quick self-test procedure to check the hardware and memory on the system. If no errors are found, the system begins the automatic boot process.

Note – Some older systems might require PROM upgrades before they will work with the Solaris system software. Contact your local service provider for more information.

SPARC: The Boot Process

The following table describes the boot process on SPARC based systems.

TABLE 15-1 SPARC: Description of the Boot Process

Boot Phase	Description
Boot PROM	1. The PROM displays system identification information and then runs self-test diagnostics to verify the system's hardware and memory. 2. Then, the PROM loads the primary boot program, <code>bootblk</code> , whose purpose is to load the secondary boot program (that is located in the <code>ufs</code> file system) from the default boot device.
Boot Programs	3. The <code>bootblk</code> program finds and executes the secondary boot program, <code>ufsboot</code> , and loads it into memory. 4. After the <code>ufsboot</code> program is loaded, the <code>ufsboot</code> program loads the kernel.
Kernel Initialization	5. The kernel initializes itself and begins loading modules by using <code>ufsboot</code> to read the files. When the kernel has loaded enough modules to mount the root (<code>/</code>) file system, the kernel unmaps the <code>ufsboot</code> program and continues, using its own resources. 6. The kernel creates a user process and starts the <code>/sbin/init</code> process, which starts other processes by reading the <code>/etc/inittab</code> file.
<code>init</code>	7. The <code>/sbin/init</code> process starts the run control (<code>rc</code>) scripts, which execute a series of other scripts. These scripts (<code>/sbin/rc*</code>) check and mount file systems, start various processes, and perform system maintenance tasks.

x86: The PC BIOS

Before the kernel is started, the system is controlled by the read-only-memory (ROM) Basic Input/Output System (BIOS), which is the firmware interface on a PC.

Hardware adapters can have an on-board BIOS that displays the physical characteristics of the device and can be used to access the device.

During the startup sequence, the PC BIOS checks for the presence of any adapter BIOS, and if found, loads and executes each adapter BIOS. Each individual adapter's BIOS runs self-test diagnostics and displays device information.

x86: Boot Subsystems

At three points during the Solaris boot process, you can make the following choices about a booting system as follows:

- **Primary Boot Subsystem (Partition Boot Menu)** – This first menu appears if multiple operating environments exist on the disk. The menu enables you to boot any of the operating environments installed. By default, the operating environment that is designed as *active* is booted.

Note that if you choose to boot a non-Solaris operating environment, you cannot reach the next two menus.

- **Interrupt the Autoboot Process** – If the autoboot process is interrupted, you can access the Solaris Device Configuration Assistant.

The Solaris Device Configuration Assistant enables you to boot the Solaris system from a different boot device, configure new or misconfigured hardware, or perform other device-related or boot-related tasks.

- **Current Boot Parameters Menu** – Two forms of this menu exist, one for a normal Solaris boot and one menu for a Solaris installation boot:

- The normal Current Boot Parameters menu enables you to boot the Solaris system with options, or enter the boot interpreter.
- The install Current Boot Parameters menu enables you to select the type of installation to be performed, or customize the boot.

The following table summarizes the purpose of the primary x86 boot interfaces. See the sections that follow for a detailed description and example of each boot interface.

TABLE 15-2 x86: Boot Subsystems

Boot Subsystem	Purpose
Primary Boot Subsystem	This menu appears if the disk you are booting from contains multiple operating environments, including the Solaris operating environment.
Secondary Boot Subsystem	This menu appears each time you boot the Solaris release. The Solaris release is booted automatically unless you choose to run the Solaris Device Configuration Assistant by interrupting the autoboot process.

TABLE 15-2 x86: Boot Subsystems (Continued)

Boot Subsystem	Purpose
Solaris Device Configuration Assistant/Boot Diskette	There are two ways to access the Solaris Device Configuration Assistant menus: <ol style="list-style-type: none">1. Use the Solaris Device Configuration Assistant boot diskette or the Solaris installation CD (on systems that can boot from the CD-ROM drive) to boot the system.2. Interrupt the autoboot process when you boot the Solaris software from an installed disk.
Current Boot Parameters Menu	This menu appears when you boot the Solaris release from the disk, CD-ROM, or the network. The menu presents a list of boot options.

Note – If you need to create the Solaris Device Configuration Assistant boot diskette, go to http://soldc.sun.com/support/drivers/dca_diskettes.

During the boot process, the boot subsystem menus allow you to customize boot choices. If the system receives no response during the time-out periods, it continues to boot automatically using the default selections. You can stop the boot process when each boot subsystem menu is displayed. Or, you can let the boot process continue automatically.

The following section provides examples of each boot subsystem screen.

x86: Booting the Solaris Release

During the device identification phase, the Solaris Device Configuration Assistant does the following:

- Scans for devices that are installed on the system
- Displays the identified devices
- Enables you to perform optional tasks such as selecting a keyboard type and editing devices and their resources

During the boot phase, the Solaris Device Configuration Assistant does the following:

- Displays a list of devices from which to boot. The device marked with an asterisk (*) is the default boot device.
- Enables you to perform optional tasks, such as editing autoboot settings and property settings, and choosing the network configuration strategy.

The following section provides examples of menus that appear during the device identification phase. The device output varies based on your system configuration.

x86: Screens Displayed During the Device Identification Phase

Several screens are displayed as the Solaris Device Configuration Assistant attempts to identify devices on the system.

x86: Configuration Assistant Screen

This screen appears each time you boot the Solaris Device Configuration Assistant. The Solaris Device Configuration Assistant runs every time the system is booted, although the autoboot process bypasses the menus.

```
Solaris Device Configuration Assistant
```

```
The Solaris(TM) (Intel Platform Edition) Device Configuration Assistant scans to identify system hardware, lists identified devices, and can boot the Solaris software from a specified device. This program must be used to install the Solaris operating environment, add a driver, or change the hardware on the system.
```

```
> To perform a full scan to identify all system hardware, choose Continue.
```

```
> To diagnose possible full scan failures, choose Specific Scan.
```

```
> To add new or updated device drivers, choose Add Driver.
```

```
About navigation...
```

- The mouse cannot be used.
- If the keyboard does not have function keys or they do not respond, press ESC. The legend at the bottom of the screen will change to show the ESC keys to use for navigation.
- The F2 key performs the default action.

```
F2_Continue
```

```
F3_Specific Scan
```

```
F4_Add Driver
```

```
F6_Help
```

x86: Bus Enumeration Screen

The Bus Enumeration screen appears briefly while the Solaris Device Configuration Assistant gathers hardware configuration data for devices that can be detected automatically.

```
Bus Enumeration
```

```
Determining bus types and gathering hardware configuration data ...
```

```
Please wait ...
```

x86: Scanning Devices Screen

The Scanning Devices screen appears while the Solaris Device Configuration Assistant manually scans for devices that can only be detected with special drivers.

Scanning Devices

The system is being scanned to identify system hardware.

If the scanning stalls, press the system's reset button. When the system reboots, choose Specific Scan or Help.

Scanning: Floppy disk controller

```
#####  
|           |           |           |           |           |  
0           20          40          60          80          100
```

Please wait ...

x86: Identified Devices Screen

The Identified Devices screen displays which devices have been identified on the system. From here, you can continue to the Boot Solaris menu or perform optional device tasks, such as setting a keyboard configuration, viewing and editing devices, setting up a serial console, and saving and deleting configurations.

Identified Devices

The following devices have been identified on this system. To identify devices not on this list or to modify device characteristics, such as keyboard configuration, choose Device Tasks. Platform types may be included in this list.

```
ISA: Floppy disk controller  
    ISA: Motherboard  
    ISA: PnP bios: 16550-compatible serial controller  
    ISA: PnP bios: 16550-compatible serial controller  
    ISA: PnP bios: Mouse controller  
    ISA: PnP bios: Parallel port  
    ISA: System keyboard (US-English)  
    PCI: Bus Mastering IDE controller  
    PCI: Universal Serial Bus  
    PCI: VGA compatible display adapter
```

F2_Continue F3_Back F4_Device Tasks F6_Help

x86: Menus Displayed During the Boot Phase

During this phase, you can determine the way in which the system is booted.

x86: Boot Solaris Menu

The Boot Solaris menu allows you to select the device from which to boot the Solaris release. You can also perform optional tasks, such as viewing and editing autoboot and property settings. Once you select a boot device and you choose Continue, the Solaris kernel begins to boot.

Boot Solaris

Select one of the identified devices to boot the Solaris kernel and choose Continue.

To perform optional features, such as modifying the autoboot and property settings, choose Boot Tasks.

An asterisk (*) indicates the current default boot device.

> To make a selection use the arrow keys, and press Enter to mark it [X].

```
[X] DISK: (*) Target 0:QUANTUM FIREBALL1280A
on Bus Mastering IDE controller on Board PCI at Dev 7, Func 1
[ ] DISK: Target 1:ST5660A
on Bus Mastering IDE controller on Board PCI at Dev 7, Func 1
[ ] DISK: Target 0:Maxtor 9 0680D4
on Bus Mastering IDE controller on Board PCI at Dev 7, Func 1
[ ] CD : Target 1:TOSHIBA CD-ROM XM-5602B 1546
on Bus Mastering IDE controller on Board PCI at Dev 7, Func 1
```

```
F2_Continue F3_Back F4_Boot Tasks F6_Help
```

x86: Current Boot Parameters Menu

This menu appears each time you boot the Solaris release from the local disk. Let the five-second timeout elapse if you want to boot the default Solaris kernel. If you want to boot with different options, select an appropriate option before the time-out period elapses.

```
<<< Current Boot Parameters >>>
Boot path: /pci@0,0/pci-ide@7,1/ide@0/cmdk@0,0:a
Boot args:
Type      b [file-name] [boot-flags] <ENTER>      to boot with options
or        i <ENTER>                                to enter boot interpreter
or        <ENTER>                                to boot with defaults
```

```
<<< timeout in 5 seconds >>>
```

Select (b)oot or (i)nterpreter:

x86: The Boot Process

The following table describes the boot process on x86 based systems.

TABLE 15-3 x86: Description of the Boot Process

Boot Phase	Description
BIOS	<p>1. When the system is turned on, the BIOS runs self-test diagnostics to verify the system's hardware and memory. The system begins to boot automatically if no errors are found. If errors are found, error messages are displayed that describe recovery options.</p> <p>The BIOS of additional hardware devices are run at this time.</p> <p>2. The BIOS boot program tries to read the first physical sector from the boot device. This first disk sector on the boot device contains the master boot record <code>mboot</code>, which is loaded and executed. If no <code>mboot</code> file is found, an error message is displayed.</p>
Boot Programs	<p>3. The master boot record, <code>mboot</code>, which contains disk information needed to find the active partition and the location of the Solaris boot program, <code>pboot</code>, loads and executes <code>pboot</code>.</p> <p>4. The Solaris boot program, <code>pboot</code> loads <code>bootblk</code>, the primary boot program, whose purpose is to load the secondary boot program that is located in the <code>ufs</code> file system.</p> <p>5. If there is more than one bootable partition, <code>bootblk</code> reads the <code>fdisk</code> table to locate the default boot partition, and builds and displays a menu of available partitions. You have a 30-second interval to select an alternate partition from which to boot. This step only occurs if there is more than one bootable partition present on the system.</p> <p>6. <code>bootblk</code> finds and executes the secondary boot program, <code>boot.bin</code> or <code>ufsboot</code>, in the root (<code>/</code>) file system. You have a 5-second interval to interrupt the autoboot to start the Solaris Device Configuration Assistant.</p> <p>7. The secondary boot program, <code>boot.bin</code> or <code>ufsboot</code>, starts a command interpreter that executes the <code>/etc/bootrc</code> script, which provides a menu of choices for booting the system. The default action is to load and execute the kernel. You have a 5-second interval to specify a boot option or to start the boot interpreter.</p>
Kernel initialization	<p>8. The kernel initializes itself and begins loading modules by using the secondary boot program (<code>boot.bin</code> or <code>ufsboot</code>) to read the files. When the kernel has loaded enough modules to mount the root (<code>/</code>) file system, the kernel unmaps the secondary boot program and continues, using its own resources.</p>

TABLE 15-3 x86: Description of the Boot Process (Continued)

Boot Phase	Description
init	9. The kernel creates a user process and starts the <code>/sbin/init</code> process, which starts other processes by reading the <code>/etc/inittab</code> file. 10. The <code>/sbin/init</code> process starts the run control (<code>rc</code>) scripts, which execute a series of other scripts. These scripts (<code>/sbin/rc*</code>) check and mount file systems, start various processes, and perform system maintenance tasks.

Managing Removable Media Topics

This topic map lists the chapters that provide information on managing removable media.

Chapter 17	Provides overview information about managing removable media from the command line.
Chapter 18	Provides step-by-step instructions for accessing removable media from the command line.
Chapter 19	Provides step-by-step instructions for formatting removable media from the command line.
Chapter 20	Provides step-by-step instructions for writing data and audio CDs.

Managing Removable Media (Overview)

This chapter provides general guidelines for managing removable media in the Solaris environment.

This is a list of the overview information in this chapter.

- “What’s New in Managing Removable Media?” on page 225
- “Where to Find Managing Removable Media Tasks” on page 226
- “Removable Media Features and Benefits” on page 226
- “Comparison of Automatic and Manual Mounting” on page 227
- “What You Can Do With Volume Management” on page 228

What’s New in Managing Removable Media?

Volume management features have been improved to fully support removable media. This improvement means that DVD-ROMs, Iomega and Universal Serial Bus (USB) Zip drives and Jaz drives, CD-ROMs, and diskettes are mounted and available for reading when they are inserted.

You can use both the Common Desktop Environment (CDE) volume management and the Solaris command line to fully manage removable media.

With the volume management improvements, you can:

- Format, label, and set read or write software protection on removable media with the new `rmformat` command. This command replaces the `fdformat` command for formatting removable media.
- Create and verify a PCFS file system on removable media with the `mkfs_pcfs` and `fsck_pcfs` commands.

- Create an `fdisk` partition and a PCFS file system on removable media on a SPARC system to facilitate data transfers to x86 systems.

Guidelines for using removable media are:

- Use UDFS and PCFS to transfer data between DVD media.
- Use the `tar` or `cpio` commands to transfer files between rewritable media such as a PCMCIA memory card or diskette with a UFS file system. A UFS file system that is created on a SPARC system is not identical to a UFS file system on PCMCIA or to a diskette that is created on an x86 system.
- Set write protection to protect important files on Jaz or Zip drives or diskettes. Apply a password to Iomega media.

Where to Find Managing Removable Media Tasks

Use these references to find step-by-step instructions for managing removable media.

Removable Media Management Task	For More Information
Access removable media	Chapter 18
Format removable media	Chapter 19
Write data and music CDs	Chapter 20

For information on using removable media with File Manager in the Common Desktop Environment, see *Solaris Common Desktop Environment: User's Guide*.

Removable Media Features and Benefits

The Solaris environment gives users and software developers a standard interface for dealing with removable media. Referred to as volume management, this interface provides three major benefits:

- By automatically mounting removable media, it simplifies their use. (For a comparison between manual and automatic mounting, see the following section.)
- It enables you to access removable media without having to become superuser.

- It allows you to give other systems on the network automatic access to any removable media on your local system. For more information, see Chapter 18.

Comparison of Automatic and Manual Mounting

The following table compares the steps involved in manual mounting (without volume management) and automatic mounting (with volume management) of removable media.

TABLE 17-1 Comparison of Manual and Automatic Mounting

Steps	Manual Mounting	Automatic Mounting
1	Insert media.	Insert media.
2	Become superuser.	For diskettes, use the <code>volcheck</code> command.
3	Determine the location of the media device.	Volume manager (<code>vol</code>) automatically performs many of the tasks previously required to manually mount and work with removable media.
4	Create a mount point.	
5	Make sure you are not in the mount point directory.	
6	Mount the device using the proper mount options.	
7	Exit the superuser account.	
8	Work with files on media.	Work with files on media.
9	Become superuser.	
10	Unmount the media device.	
11	Eject media.	Eject media.
12	Exit the superuser account.	

What You Can Do With Volume Management

Essentially, volume management enables you to access removable media just as manual mounting does, but more easily and without the need for superuser access. To make removable media easier to work with, you can mount removable media in easy-to-remember locations.

TABLE 17-2 How to Access Data on Removable Media Managed by Volume Manager

Access	Insert	Find the Files Here
Files on the first diskette	The diskette and enter <code>volcheck</code>	<code>/floppy</code>
Files on the first removable hard disk	The removable hard disk and enter <code>volcheck</code>	<code>/rmdisk/jaz0</code> or <code>/rmdisk/zip0</code>
Files on the first CD	The CD and wait for a few seconds	<code>/cdrom/volume-name</code>
Files on the first DVD	The DVD and wait for a few seconds	<code>/dvd/volume-name</code>
Files on the first PCMCIA	The PCMCIA and wait for a few seconds	<code>/pcmem/pcmem0</code>

If your system has more than one type of removable device, see the following table for their access points.

TABLE 17-3 Where to Access Removable Media

Media Device	Access File Systems With This Path	Access Raw Data With This Path
First diskette drive	<code>/floppy/floppy0</code>	<code>/vol/dev/aliases/floppy0</code>
Second diskette drive	<code>/floppy/floppy1</code>	<code>/vol/dev/aliases/floppy1</code>
First CD-ROM drive	<code>/cdrom/cdrom0</code>	<code>/vol/dev/aliases/cdrom0</code>
Second CD-ROM drive	<code>/cdrom/cdrom1</code>	<code>/vol/dev/aliases/cdrom1</code>
First removable hard disk	<code>/rmdisk/jaz0</code>	<code>/vol/dev/aliases/jaz0</code>
	<code>/rmdisk/zip0</code>	<code>/vol/dev/aliases/zip0</code>
First PCMCIA drive	<code>/pcmem/pcmem0</code>	<code>/vol/dev/aliases/pcmem0</code>

Accessing Removable Media (Tasks)

This chapter describes how to access removable media from the command line in the Solaris environment.

For information on the procedures associated with accessing removable media, see the following:

- “Accessing Removable Media (Task Map)” on page 229
- “Accessing Removable Media on a Remote System (Task Map)” on page 238

For background information on removable media, see Chapter 17.

Accessing Removable Media (Task Map)

Task	Description	For Instructions
1. (Optional) Add the removable media drive	Add the removable media drive to your system, if necessary.	“How to Add a New Removable Media Drive” on page 232
2. (Optional) Decide whether you want to use removable media with or without volume management (vold)	Volume management (vold) runs by default. Decide whether you want to use removable media with or without volume management.	“Stopping and Starting Volume Management (vold)” on page 233
3. Access removable media	Access different kinds of removable media with or without volume management running.	“How to Access Information on Removable Media” on page 233

Task	Description	For Instructions
4. (Optional) Copy files or directories	Copy files or directories from the media as you would from any other location in the file system.	"How to Copy Information From Removable Media" on page 234
5. (Optional) Configure a system to play musical CDs or DVDs	You can configure a system to play musical CDs or DVDs, but you will need third-party software to play the media.	"How to Play a Musical CD or DVD" on page 235
6. Find out if the media still in use	Before ejecting the media, find out if it is still in use.	"How to Find Out If Removable Media Is Still in Use" on page 236
7. Eject the Media	When you finish, eject the media from the drive.	"How to Eject Removable Media" on page 237

Accessing Removable Media (Overview)

You can access information on removable media with or without using volume manager. For information on accessing information on removable media with CDE's File Manager, see "Using Removable Media with File Manager" in *Solaris Common Desktop Environment: User's Guide*.

Starting in the Solaris 8 6/00 release, volume manager (`vold`) actively manages all removable media devices. This means any attempt to access removable media with device names such as `/dev/rdisk/cntndnsn` or `/dev/dsk/cntndnsn` will be unsuccessful.

Using Removable Media Names

You can access all removable media with different names. The following table describes the different media names that can be accessed with or without volume management.

TABLE 18-1 Removable Media Names

Media	Volume Management Device Name	Volume Management Device Alias Name	Device Name
First diskette drive	/floppy	/vol/dev/aliases/floppy0	/dev/rdiskette /vol/dev/rdiskette0/ <i>volume-name</i>
	/cdrom0	/vol/dev/aliases/cdrom0	/vol/dev/rdsk/cntn[dn]/
	/cdrom1 /cdrom2	/vol/dev/aliases/cdrom1 /vol/dev/aliases/cdrom2	<i>volume-name</i>
First, second, third CD-ROM or DVD-ROM drives	/rmdisk/jaz0	/vol/dev/aliases/jaz0	/vol/dev/rdsk/cntndn/ <i>volume-name</i>
	/rmdisk/jaz1	/vol/dev/aliases/jaz1	
	/rmdisk/jaz2	/vol/dev/aliases/jaz2	
First, second, third Jaz drive	/rmdisk/zip0	/vol/dev/aliases/zip0	/vol/dev/rdsk/cntndn/ <i>volume-name</i>
	/rmdisk/zip1	/vol/dev/aliases/zip1	
	/rmdisk/zip2	/vol/dev/aliases/zip2	
First, second, third Zip drive	/pcmem/pcmem0	/vol/dev/aliases/pcmem0	/vol/dev/rdsk/cntndn/ <i>volume-name</i>
	/pcmem/pcmem1	/vol/dev/aliases/pcmem1	
	/pcmem/pcmem2	/vol/dev/aliases/pcmem2	
First, second, third PCMCIA drive			

Use this table to identify which removable media name to use with specific Solaris commands.

Solaris Command	Device Name	Usage Examples
ls, more, vi	/floppy	ls /floppy/myfiles/
	/cdrom	more /cdrom/myfiles/filea
	/rmdisk/zip0	
	/rmdisk/jaz0	
	/pcmem/pcmem0	
fsck, newfs, mkfs	/vol/dev/aliases/floppy0	newfs /vol/dev/aliases/floppy0
	/vol/dev/rdsk/cntndn	mkfs -F udfs /vol/dev/rdsk/cntndn

Guidelines for Accessing Removable Media Data

Most CDs and DVDs are formatted to the ISO 9660 standard, which is portable, so most CDs and DVDs can be mounted by volume management. However, CDs or DVDs with UFS file systems are not portable between architectures, so they must be used on the architecture for which they were designed.

For example, a CD or DVD with a UFS file system for a SPARC platform cannot be recognized by an x86 platform. Likewise, an x86 UFS CD cannot be mounted by volume management on a SPARC platform. The same limitation applies to diskettes. (Actually, some architectures share the same bit structure, so occasionally a UFS format specific to one architecture will be recognized by another architecture, but the UFS file system structure was not designed to guarantee this compatibility).

To accommodate the different formats, the CD or DVD is split into slices, which are similar in effect to partitions on hard disks. The 9660 portion is portable, but the UFS portion is architecture-specific. If you are having trouble mounting a CD or DVD, particularly if it is an installation CD or DVD, make sure its UFS file system is appropriate for your system's architecture (check the label on the CD or DVD).

Accessing Jaz Drives or Zip Drives

You can determine whether accessing your Jaz or Zip drives changes from previous Solaris releases, depending on the following:

- If you are upgrading from the Solaris 8 6/00 release to the Solaris 9 release, you can continue to access your Jaz drives and Zip drives in the same way as in previous releases.
- If you are freshly installing the Solaris 9 release, you cannot access your Jaz drives and Zip drives in the same way as in previous Solaris releases.

Follow these steps if you want to access your Jaz and Zip drives in the same way as in previous Solaris releases:

1. Comment the following line in the `/etc/vold.conf` file by inserting a pound (#) sign at the beginning of the text, like this:

```
# use rmdisk drive /dev/rdisk/c*s2 dev_rmdisk.so rmdisk%d
```

2. Reboot the system.

▼ How to Add a New Removable Media Drive

Adding a new removable media drive involves creating the `/reconfigure` file and rebooting the system so that volume management recognizes the new media drive.

1. **Become superuser.**
2. **Create the `/reconfigure` file.**

```
# touch /reconfigure
```

3. Bring the system to run level 0.

```
# init 0
```

4. Turn off power to the system.

5. Connect the new media drive.

See your hardware handbook for specific instructions.

6. Turn on power to the system.

The system comes up to multiuser mode automatically.

Stopping and Starting Volume Management (vold)

Occasionally, you might want to manage media without the help of volume management. This section describes how to stop and restart volume management.

▼ How to Stop Volume Management (vold)

1. Make sure media is not being used.

If you are not sure whether you have found all users of the media, use the `fuser` command, as described in “How to Find Out If Removable Media Is Still in Use” on page 236.

2. Become superuser.

3. Enter the `volmgt stop` command.

```
# /etc/init.d/volmgt stop  
#
```

▼ How to Restart Volume Management (vold)

1. Become superuser.

2. Enter the `volmgt start` command.

```
# /etc/init.d/volmgt start  
volume management starting.
```

▼ How to Access Information on Removable Media

1. Insert the media.

The media is mounted after a few seconds.

2. Check for media in the drive.

```
% volcheck
```

Use the appropriate device name to access information by using the command-line interface. See Table 18–1 for an explanation of device names.

3. List the contents of the media.

```
% ls /media
```

Examples—Accessing Information on Removable Media

Access information on a diskette as follows:

```
$ volcheck
$ ls /floppy
myfile
```

Access information on a Jaz drive as follows:

```
$ volcheck
$ ls /rmdisk
jaz0/          jaz1/
```

Access information on a CD-ROM as follows:

```
$ volcheck
$ ls /cdrom
solaris_9_sparc/
```

View the symbolic links on a CD-ROM as follows:

```
$ ls -lL /cdrom/cdrom0
total 166
drwxr-xr-x  4 root    root      2048 Jul 21 05:18 MU
drwxr-xr-x  4 root    root      2048 Jul 21 05:18 Solaris_7_MU3
-rwxr-xr-x  1 root    root      30952 Jul 21 05:18 backout_mu
-rwxr-xr-x  1 root    root      49604 Jul 21 05:18 install_mu
```

Access information on a PCMCIA memory card as follows

```
$ ls /pcmem/pcmem0
pcmem0 myfiles
```

▼ How to Copy Information From Removable Media

You can access files and directories on removable media just like any other file system. The only significant restrictions are ownership and permissions.

For instance, if you copy a file from a CD into your file system, you'll be the owner, but you won't have write permissions (because the file never had them on the CD). You'll have to change the permissions yourself.

1. Make sure the media is mounted.

```
$ ls /media
```

The `ls` command displays the contents of a mounted media. If no contents are displayed, see “How to Access Information on Removable Media” on page 233.

2. (Optional) Copy the files or directories.

For example, for a CD, you would do the following:

```
$ cp /cdrom/sol_8_u3_sparc_2/Solaris_8/EA/products/Live*/README*
$ ls -l
-r--r--r-- 1 pmorph users 3002 May 9 08:09 README_Live_Upgrade
```

For example, for a PCMCIA memory card, you would do the following:

```
$ cp /pcmem/pcmem0/readme2.doc .
$ cp -r /pcmem/pcmem0/morefiles .
```

▼ How to Play a Musical CD or DVD

To play musical media from a media drive attached to a system running the Solaris release, you’ll need to access public domain software, such as `xmcd`, that is available from the following locations:

- <http://www.ibiblio.org/tkan/xmcd>

This site includes frequent updates to the `xmcd` software, which includes the version of `xmcd` that plays on newer Sun hardware, such as the Sun Blade™ systems.

- http://www.sun.com/software/solaris/freeware/pkggs_download.html

Keep the following in mind when using the `xmcd` software with CDDA (CD Digital Audio) support to play musical media:

- Use `xmcd`, version 3.1 (or later) on Sun Blade systems because this version has CDDA support, which must be enabled in order to listen to CDs on these systems.
- Enable CDDA by launching `xmcd`, clicking on the options button (it has a hammer and screwdriver on the button), and then by clicking on “CDDA playback”.
- When CDDA is enabled, audio is directed to the audio device, so headphones and external speakers should be connected to the audio device and not to the media drive itself.
- CDDA can be enabled on other machines too. Enabling CDDA is required for playing media on the Sun Blade systems.

Consider the following issues as well:

- If you are using `xmcd` with standard playback on a system that *does not* have an internal connection from the CD-ROM to the audio device, you must insert headphones into the CD-ROM drive’s headphone port.

- If you are using `xmcd` with standard playback on a system that *does* have an internal connection from the CD-ROM to the audio device, you can do either of the following:
 1. Insert headphones into the headphone port of the CD-ROM drive.
 2. Insert headphones into the headphone port on the audio device.

If you choose #2, you must do the following:

- Select the internal CD as the input device.
- Make sure that Monitor Volume is non-zero.

You can do both of these from `sdtaudiocontrol`'s record panel.

Once you install the `xmcd` software, you can play a musical CD simply by inserting it into the CD-ROM drive and starting the `xmcd` control panel.

1. **Install the `xmcd` software.**
2. **Insert the media into the media drive.**
3. **Invoke the `xmcd` command.**

```
% ./xmcd &
```

▼ How to Find Out If Removable Media Is Still in Use

1. **Become superuser.**
2. **Identify the processes accessing the media.**

```
# fuser -u [-k] /media
```

-u	Displays the user of the media.
-k	Kills the process accessing the media.

For more information on using the `fuser` command, see `fuser(1M)`.

3. **(Optional) Kill the process accessing the media.**

```
# fuser -u -k /media
```



Caution – Killing the process accessing the media should only be used in emergency situations.

4. Verify the process is gone.

```
# pgrep process-ID
```

Example—Finding Out If the Media Is Still in Use

The following example shows that the process 26230c, owner riple, is accessing the /cdrom/cdrom0/Solaris_8/EA/products/Live_Upgrade_1.0 directory.

```
# fuser -u /cdrom/cdrom0/Solaris_8/EA/products/Live_Upgrade_1.0  
/cdrom/cdrom0/Solaris_8/EA/products/Live_Upgrade_1.0: 26230c(ripley)
```

▼ How to Eject Removable Media

1. Make sure the media is not being used.

Remember, media is “being used” if a shell or an application is accessing any of its files or directories. If you are not sure whether you have found all users of a CD (a shell hidden behind a desktop tool might be accessing it), use the `fuser` command, as described in “How to Find Out If Removable Media Is Still in Use” on page 236.

2. Eject the media.

```
# eject media
```

For example, for a CD, you would do the following

```
# eject cdrom
```

For example, for a PCMCIA memory card, you would do the following:

```
# eject pcmem0
```

Accessing Removable Media on a Remote System (Task Map)

The following table describes the tasks need to access removable media on a remote system.

Task	Description	For Instructions
1. Make local media available to remote systems	Add the removable media drive to your system, if necessary.	"How to Make Local Media Available to Other Systems" on page 238
2. Access removable media on remote systems	Insert the media into the drive.	"How to Access Information on Removable Media" on page 233

▼ How to Make Local Media Available to Other Systems

You can configure your system to share its media drives to make any media in those drives available to other systems. (This does not apply to musical CDs.) Once your media drives are shared, other systems can access the media they contain simply by mounting them, as described in "How to Access Removable Media on Remote Systems" on page 241.

1. Become superuser.
2. Find out whether the NFS daemon (`nfsd`) is running.

```
# ps -ef | grep nfsd
root 14533  1 17 10:46:55 ?      0:00 /usr/lib/nfs/nfsd -a 16
root 14656 289  7 14:06:02 pts/3 0:00 grep nfsd
```

If the daemon is running, a line for `/usr/lib/nfs/nfsd` will appear, as shown above. If the daemon is not running, only the `grep nfsd` line will appear.

3. Identify the `nfsd` status and select one of the following:
 - a. If `nfsd` is running, go to Step 8.
 - b. If `nfsd` is *not* running, continue with Step 4.
4. Create a dummy directory for `nfsd` to share.

```
# mkdir / dummy-dir
```

dummy-dir

Can be any directory name; for example, *dummy*. This directory will not contain any files. Its only purpose is to “wake up” the NFS daemon so that it notices your shared media drive.

5. Add the following entry into the `/etc/dfs/dfstab` file.

```
share -F nfs -o ro [-d comment] /dummy-dir
```

When you start the NFS daemon, it will see this entry, “wake up,” and notice the shared media drive. Note that the comment (preceded by `-d`) is optional.

6. Start the NFS daemon.

```
# /etc/init.d/nfs.server start
```

7. Verify that the NFS daemon is indeed running.

```
# ps -ef | grep nfsd
root 14533    1 17 10:46:55 ?        0:00 /usr/lib/nfs/nfsd -a 16
root 14656   289  7 14:06:02 pts/3  0:00 /grep nfsd
```

8. Eject any media currently in the drive.

```
# eject media
```

9. Assign root write permissions to the `/etc/rmmount.conf` file.

```
# chmod 644 /etc/rmmount.conf
```

10. Add the following lines to the `/etc/rmmount.conf` file.

```
# File System Sharing
share media*
```

These lines share any media loaded into your system’s CD-ROM drive. You can, however, limit sharing to a particular CD or series of CDs, as described in `share(1M)`.

11. Remove write permissions from the `/etc/rmmount.conf` file.

```
# chmod 444 /etc/rmmount.conf
```

This step returns the file to its default permissions.

12. Load the media.

The media you now load, and all subsequent media, will be available to other systems. Remember to wait until the light on the drive stops blinking before you verify this task.

To access the media, the remote user must mount it by name, according to the instructions in “How to Access Removable Media on Remote Systems” on page 241.

13. Verify that the media is indeed available to other systems by using the `share` command.

If the media is available, its share configuration will be displayed. (The shared dummy directory will also be displayed.)

```
# share
- /dummy ro "dummy dir to wake up NFS daemon"
- /cdrom/sol_9_sparc ro ""
```

Example—Making Local CDs Available to Other Systems

The following example shows how to make any local CD available to other systems on the network.

```
# ps -ef | grep nfsd
  root 10127  9986  0 08:25:01 pts/2    0:00 grep nfsd
  root 10118    1  0 08:24:39 ?          0:00 /usr/lib/nfs/nfsd -a
# mkdir /dummy
# vi /etc/dfs/dfstab
(Add the following line:)
share -F nfs -o ro /dummy
# eject cdrom0
# chmod 644 /etc/rmmount.conf
# vi /etc/rmmount
(Add the following line to the File System Sharing section:)
share cdrom*
# chmod 444 /etc/rmmount.conf
(Load a CD.)
# share
- /dummy ro ""
- /cdrom/sol_9_sparc/s5 ro ""
- /cdrom/sol_9_sparc/s4 ro ""
- /cdrom/sol_9_sparc/s3 ro ""
- /cdrom/sol_9_sparc/s2 ro ""
- /cdrom/sol_9_sparc/s1 ro ""
- /cdrom/sol_9_sparc/s0 ro ""
#
```

Example—Making Local Diskettes Available to Other Systems

The following example shows how to make any local diskette available to other systems on the network.

```
# ps -ef | grep nfsd
  root 10127  9986  0 08:25:01 pts/2    0:00 grep nfsd
  root 10118    1  0 08:24:39 ?          0:00 /usr/lib/nfs/nfsd -a
# mkdir /dummy
# vi /etc/dfs/dfstab
(Add the following line:)
```



```

share -F nfs -o ro /dummy
# eject floppy0
# chmod 644 /etc/rmmount.conf
# vi /etc/rmmount
(Add the following line to the File System Sharing section.)
share floppy*
# chmod 444 /etc/rmmount.conf
(Load a diskette.)
# volcheck -v
media was found
# share
-           /dummy    ro    ""
-           /floppy/myfiles  rw  ""

```

Example—Making Local PCMCIA Memory Cards Available to Other Systems

The following example shows how to make any local PCMCIA memory card available to other systems on the network.

```

# ps -ef | grep nfsd
  root 10127  9986  0 08:25:01 pts/2    0:00 grep nfsd
  root 10118    1  0 08:24:39 ?        0:00 /usr/lib/nfs/nfsd -a
# mkdir /dummy
# vi /etc/dfs/dfstab
(Add the following line:)
share -F nfs -o ro /dummy
# eject pcmem0
# chmod 644 /etc/rmmount.conf
# vi /etc/rmmount
(Add the following line to the File System Sharing section:)
share floppy*
# chmod 444 /etc/rmmount.conf
(Load a PCMCIA memory card.)
# volcheck -v
media was found
# share
-           /dummy    ro    ""
-           /pcmem/myfiles  rw  ""

```

▼ How to Access Removable Media on Remote Systems

You can access media on a remote system by mounting it manually into your file system, provided the other system has shared its media according to the instructions in “How to Make Local Media Available to Other Systems” on page 238.

1. Select an existing directory to serve as the mount point or create one.

```
$ mkdir directory
```

directory is the name of the directory that you create to serve as a mount point for the other system's CD.

2. Find the name of the media you want to mount.

```
$ showmount -e system-name
export list for system-name:
/cdrom/sol_9_sparc (everyone)
```

3. As superuser, mount the media.

```
# mount -F nfs -o ro system-name:/media/media-name local-mount-point
```

<i>system-name</i>	The name of the system whose media you will mount.
<i>media-name</i>	The name of the media you want to mount.
<i>local-mount-point</i>	The local directory onto which you will mount the remote media.

4. Log out as superuser.

5. Verify that the media is mounted.

```
$ ls /media
```

Example—Accessing CDs on Other Systems

The following example shows how to mount the CD named `sol_9_sparc` from the remote system `starbug` onto the `/cdrom` directory of the local system.

```
$ showmount -e starbug
export list for starbug:
/cdrom/sol_9_sparc (everyone)
$ su
Password: password
# mount -F nfs -o ro starbug:/cdrom/sol_9_sparc /cdrom
# exit
$ ls /cdrom
cdrom0      sol_9_sparc
```

Example—Accessing Diskettes on Other Systems

The following example shows how to mount the diskette named `myfiles` from the remote system `mars` onto the `/floppy` directory of the local system.

```
$ cd /net/mars
$ ls /floppy
floppy0      myfiles
```

```
$ su
Password: password
# mount -F nfs mars:/floppy/myfiles /floppy
# exit
$ ls /floppy
myfiles
```

Example—Accessing PCMCIA Memory Cards on Other Systems

The following example shows how to mount the PCMCIA memory card named `myfiles` from the remote system `mars` onto the `/pcmem` directory of the local system.

```
$ cd /net/mars
$ ls /pcmem
pcmem0      myfiles
$ su
Password: password
# mount -F nfs mars:/pcmem/myfiles /pcmem
# exit
$ ls /pcmem
myfiles
```

Formatting Removable Media (Tasks)

This chapter describes how to format removable media from the command line in the Solaris environment.

For information on the procedures associated with formatting removable media, see “Formatting Removable Media (Task Map)” on page 245.

For background information on removable media, see Chapter 17.

Formatting Removable Media (Task Map)

Task	Description	For Instructions
1. Load unformatted media	Insert the media into the drive and enter the <code>volcheck</code> command.	“How to Load a Removable Media” on page 248
2. Format the media	Format removable media.	“How to Format Removable Media (<code>rmformat</code>)” on page 250
3. (Optional) Add a UFS file system	Add a UFS file system to use the diskette for transferring files.	“How to Format Removable Media for Adding a File System” on page 250

Task	Description	For Instructions
4. (Optional) Check the media	Verify the integrity of the file system on the media.	"How to Check a File System on Removable Media" on page 252
5. (Optional) Repair bad blocks on the media	Repair any bad blocks on the media, if necessary.	"How to Repair Bad Blocks on Removable Media" on page 253
6. (Optional) Apply Read or Write and Password Protection	Apply read or write protection or password protection on the media, if necessary.	"How to Enable or Disable Write Protection on Removable Media" on page 253

Formatting Removable Media Overview

The `rmformat` command is a non-superuser utility that you can use to format and protect rewritable removable media. The `rmformat` command has three formatting options:

- `quick` – This option formats removable media without certification or with limited certification of certain tracks on the media.
- `long` – This option formats removable media completely. For some devices, the use of this option might include the certification of the whole media by the drive itself.
- `force` – This option formats completely without user confirmation. For media with a password-protection mechanism, this option clears the password before formatting. This feature is useful when a password is forgotten. On media without password protection, this option forces a long format.

Formatting Removable Media Guidelines

Keep the following in mind when formatting removable media:

- Close and quit the file manager window.
File Manager automatically displays a formatting window when you insert an unformatted media. To avoid the window, quit from File Manager. If you prefer to keep File Manager open, quit the formatting window when it appears.
- Volume manager (`vol`) mounts file systems automatically so you might have to unmount media before you can format it, if it contains an existing file system.

Removable Media Hardware Considerations

This section describes removable media hardware considerations.

Diskette Hardware Considerations

Keep the following in mind when formatting diskettes:

- For information on diskette names, see Table 18-1.
- Diskettes that are not named (that is, they have no “label”) are assigned the default name of noname.

A Solaris system can format diskettes for use on both Solaris and DOS systems. However, the hardware platform imposes some limitations. These limitations are summarized in the following table.

Platform Type	Diskettes Format Type
SPARC based systems	UFS
	MS-DOS or NEC-DOS (PCFS)
	UDFS
x86 based systems	UFS
	MS-DOS or NEC-DOS (PCFS)
	UDFS

Diskettes formatted for UFS are restricted to the hardware platform on which they were formatted. In other words, a UFS diskette formatted on a SPARC based platform cannot be used for UFS on an x86 platform, nor can a diskette formatted on an x86 platform be used on a SPARC based platform. This is because the SPARC and x86 UFS formats are different. SPARC uses little-endian bit coding, x86 uses big-endian.

A complete format for SunOS file systems consists of the basic “bit” formatting plus the structure to support a SunOS file system. A complete format for a DOS file system consists of the basic “bit” formatting plus the structure to support either an MS-DOS or an NEC-DOS file system. The procedures required to prepare a diskette for each type of file system are different. Therefore, before you format a diskette, consider which procedure to follow. For more information, see “Formatting Removable Media (Task Map)” on page 245.

On a Solaris system (either SPARC or x86), you can format diskettes with the following densities.

Diskette Size	Diskette Density	Capacity
3.5"	High Density (HD)	1.44 Mbytes
3.5"	Double Density (DD)	720 Kbytes

By default, the diskette drive formats a diskette to a like density. This default means that a 1.44 Mbyte drive attempts to format a diskette for 1.44 Mbytes, whether the diskette is in fact a 1.44 Mbyte diskette or not, unless you instruct it otherwise. In other words, a diskette can be formatted to its capacity or lower, and a drive can format to its capacity or lower.

PCMCIA Memory Card Hardware Considerations

A Solaris platform can format PCMCIA memory cards for use on both Solaris and DOS platforms. However, the hardware platform imposes some limitations. These limitations are summarized in the following table.

Platform Type	PCMCIA Memory Cards Format Type
SPARC based systems	UFS
	MS-DOS or NEC-DOS (PCFS)
x86 based systems	UFS
	MS-DOS or NEC-DOS (PCFS)

PCMCIA memory cards formatted for UFS are restricted to the hardware platform on which they were formatted. In other words, a UFS PCMCIA memory card formatted on a SPARC platform cannot be used for UFS on an x86 platform. Likewise, PCMCIA memory cards formatted on an x86 platform cannot be used on a SPARC platform. This is because the SPARC and x86 UFS formats are different.

A complete format for UFS file systems consists of the basic "bit" formatting plus the structure to support a UFS file system. A complete format for a DOS file system consists of the basic "bit" formatting plus the structure to support either an MS-DOS or an NEC-DOS file system. The procedures required to prepare a PCMCIA memory card for each type of file system are different. Therefore, before you format a PCMCIA memory card, consider which file system you are using.

▼ How to Load a Removable Media

1. **Insert the media.**
2. **Make sure the media is formatted.**

If you aren't sure, insert it and check the status messages in the console, as described in Step 3. If you need to format the diskette, go to "How to Format Removable Media (rmformat)" on page 250.

3. Notify volume management.

```
$ volcheck -v  
media was found
```

Two status messages are possible:

media was found

Volume management detected the media and will attempt to mount it in the directory described in Table 18-1.

If the media is formatted properly, no error messages appear in the console.

If the media is not formatted, the "media was found" message is still displayed, but the error messages similar to the following appear in the Console:

```
fd0: unformatted diskette or no diskette in  
the drive
```

```
fd0: read failed (40 1 0)
```

```
fd0: bad format
```

You must format the media before volume management can mount it. For more information, see Chapter 19.

no media was found

Volume management did not detect the media. Make sure the media is inserted properly and run volcheck again. If unsuccessful, check the media, it could be damaged. You can also try to mount the media manually.

4. Verify that the media was mounted by listing its contents.

For example, do the following for a diskette:

```
$ ls /floppy  
floppy0 myfiles
```

As described earlier, floppy0 is a symbolic link to the actual name of the diskette, In this case, myfiles. If the diskette has no name but is formatted correctly, the system will refer to it as unnamed_floppy.

If nothing appears under the /floppy directory, the diskette was either not mounted or is not formatted properly. To find out, run the mount command and look for the line that begins with /floppy (usually at the end of the listing):

```
/floppy/name on /vol/dev/diskette0/name
```

If the line does not appear, the diskette was not mounted. Check the console window for error messages.

▼ How to Format Removable Media (`rmformat`)

You can use the `rmformat` command to format the media. By default, this command creates two partitions on the media: partition 0 and partition 2 (the whole media).

1. **Verify that the volume manager is running, which means you can use the shorter nickname for the device name.**

```
$ ps -ef | grep vold
root  212      1  0   Nov 03 ?           0:01 /usr/sbin/vold
```

For information on starting `vold`, see “How to Restart Volume Management (`vold`)” on page 233. For information on identifying media device names, see “Using Removable Media Names” on page 230.

2. **Format the removable media.**

```
$ rmformat -F [ quick | long | force ] device-name
```

See the previous section for more information on `rmformat` formatting options.

If the `rmformat` output indicates bad blocks, see “How to Repair Bad Blocks on Removable Media” on page 253 for information on repairing bad blocks.

3. **(Optional) Label the removable media with an 8-character label to be used in the Solaris environment.**

```
$ rmformat -b label device-name
```

For information on creating a DOS label, see `mkfs_pcfs(1M)`.

Examples—Formatting Removable Media

This example shows how to format a diskette.

```
$ rmformat -F quick /dev/rdiskette
Formatting will erase all the data on disk.
Do you want to continue? (y/n) y
.....
```

This example shows how to format a Zip drive.

```
$ rmformat -F quick /vol/dev/aliases/zip0
Formatting will erase all the data on disk.
Do you want to continue? (y/n) y
.....
```

▼ How to Format Removable Media for Adding a File System

1. **Format the media.**

```
$ rmformat -F quick device-name
```

2. (Optional) Create an alternate Solaris partition table.

```
$ rmformat -s slice-file device-name
```

A sample slice file looks like the following:

```
slices: 0 = 0, 30MB, "wm", "home" :  
        1 = 30MB, 51MB :  
        2 = 0, 94MB, "wm", "backup" :  
        6 = 81MB, 13MB
```

3. Become superuser.

4. Determine the appropriate file system type and select one of the following:

a. Create a UFS file system.

```
# newfs device-name
```

b. Create a UDFS file system.

```
# mkfs -F udfs device-name
```

Example—Formatting a Diskette for a UFS File System

The following example shows how to format a diskette and create a UFS file system on the diskette.

```
$ rmformat -F quick /vol/dev/aliases/floppy0  
Formatting will erase all the data on disk.  
Do you want to continue? (y/n) y  
$ su  
# /usr/sbin/newfs /vol/dev/aliases/floppy0  
newfs: construct a new file system /dev/rdiskette: (y/n)? y  
/dev/rdiskette: 2880 sectors in 80 cylinders of 2 tracks, 18 sectors  
      1.4MB in 5 cyl groups (16 c/g, 0.28MB/g, 128 i/g)  
super-block backups (for fsck -F ufs -o b=#) at:  
   32, 640, 1184, 1792, 2336,  
#
```

Example—Formatting a PCMCIA Memory Card for a UFS File System

The following example shows how to format a PCMCIA memory card and create a UFS file system on the card.

```
$ rmformat -F quick /vol/dev/aliases/pcm0  
$ su  
# /usr/sbin/newfs -v /vol/dev/aliases/pcm0  
newfs: construct a new file system /vol/dev/aliases/pcm0: (y/n)? y  
.  
.
```

```
.  
#
```

Examples—Formatting Removable Media for a PCFS File System

This example shows how to create an alternate fdisk partition.

```
$ rmformat -F quick /dev/rdisk/c0t4d0s2:c  
Formatting will erase all the data on disk.  
Do you want to continue? (y/n) y  
$ su  
# fdisk /dev/rdisk/c0t4d0s2:c  
# mkfs -F pcfs /dev/rdisk/c0t4d0s2:c  
Construct a new FAT file system on /dev/rdisk/c0t4d0s2:c: (y/n)? y  
#
```

This example shows how to create a PCFS file system without an fdisk partition.

```
$ rmformat -F quick /dev/rdiskette  
Formatting will erase all the data on disk.  
Do you want to continue? (y/n) y  
$ su  
# mkfs -F pcfs -o nofdisk,size=2 /dev/rdiskette  
Construct a new FAT file system on /dev/rdiskette: (y/n)? y  
#
```

▼ How to Check a File System on Removable Media

1. Become superuser.
2. Identify the name service and select one of the following:
 - a. Check a UFS file system.

```
# fsck -F ufs device-name
```
 - b. Check a UDFS file system.

```
# fsck -F udfs device-name
```
 - c. Check a PCFS file system.

```
# fsck -F pcfs device-name
```

Example—Checking a PCFS File System on Removable Media

The following example shows how check the consistency of a PCFS file system on media.

```
# fsck -F pcfs /dev/rdisk/c0t4d0s2
** /dev/rdisk/c0t4d0s2
** Scanning file system meta-data
** Correcting any meta-data discrepancies
1457664 bytes.
0 bytes in bad sectors.
0 bytes in 0 directories.
0 bytes in 0 files.
1457664 bytes free.
512 bytes per allocation unit.
2847 total allocation units.
2847 available allocation units.
#
```

▼ How to Repair Bad Blocks on Removable Media

You can only use the `rmformat` command to verify, analyze, and repair bad sectors that are found during verification if the drive supports bad block management. Most diskettes and PCMCIA memory cards do not support bad block management.

If the drive supports bad block management, a best effort is made to rectify the bad block. If the bad block cannot be rectified despite the best effort mechanism, a message indicates a failure to repair.

1. Repair bad blocks on removable media.

```
$ rmformat -c block-numbers device-name
```

Supply the block number in decimal, octal, or hexadecimal format from a previous `rmformat` session.

2. Verify the media.

```
$ rmformat -v read device-name
```

Applying Read or Write and Password Protection to Removable Media

You can apply read protection or write protection and set a password on Iomega media such as Zip drives and Jaz drives.

▼ How to Enable or Disable Write Protection on Removable Media

1. Determine whether you want to enable or disable write protection and select one of the following:

a. Enable write protection.

```
$ rmformat -w enable device-name
```

b. Disable write protection.

```
$ rmformat -w disable device-name
```

2. Verify whether the media's write protection is enabled or disabled.

```
$ rmformat -p device-name
```

▼ How to Enable or Disable Read or Write Protection and a Password on Iomega Media

You can apply a password with a maximum of 32 characters for Iomega media that support this feature. You cannot set read protection or write protection without a password on Iomega media. In this situation, you are prompted to provide a password.

You receive a warning message if you attempt to apply a password on media that does not support this feature.

1. Determine whether you want to enable or disable read protection or write protection and a password.

a. Enable read protection or write protection.

```
$ rmformat -W enable device-name
Please enter password (32 chars maximum): xxx
Please reenter password:
```

```
$ rmformat -R enable device-name
Please enter password (32 chars maximum): xxx
Please reenter password:
```

b. Disable read protection or write protection and remove the password.

```
$ rmformat -W disable device-name
Please enter password (32 chars maximum): xxx
```

```
$ rmformat -R disable device-name
Please enter password (32 chars maximum): xxx
```

2. Verify whether the media's read protection or write protection is enabled or disabled.

```
$ rmformat -p device-name
```

Examples—Enabling or Disabling Read or Write Protection

This example shows how to enable write protection and set a password on a Zip drive.

```
$ rmformat -W enable /vol/dev/aliases/zip0  
Please enter password (32 chars maximum): xxx  
Please reenter password: xxx
```

This example shows how to disable write protection and remove the password on a Zip drive.

```
$ rmformat -W disable /vol/dev/aliases/zip0  
Please enter password (32 chars maximum): xxx
```

This example shows how to enable read protection and set a password on a Zip drive.

```
rmformat -R enable /vol/dev/aliases/zip0  
Please enter password (32 chars maximum): xxx  
Please reenter password: xxx
```

This example shows to disable read protection and remove the password on a Zip drive.

```
$ rmformat -R disable /vol/dev/aliases/zip0  
Please enter password (32 chars maximum): xxx
```

Writing CDs (Tasks)

This chapter provides step-by-step instructions for writing and copying data and audio CDs with the `cdwr` command.

- “How to Restrict User Access to Removable Media with RBAC” on page 260
- “How to Identify a CD Writer” on page 260
- “How to Check the CD Media” on page 261
- “How to Create an ISO 9660 File System for a Data CD” on page 262
- “How to Create a Multi-Session Data CD” on page 263
- “How to Create an Audio CD” on page 265
- “How to Extract an Audio Track on a CD” on page 266
- “How to Copy a CD” on page 267
- “How to Erase CD-RW Media” on page 267

Working with Audio and Data CDs

This Solaris release provides the `cdwr` command, which enables you to write CD file systems in ISO 9660 format with Rock Ridge or Joliet extensions on CD-R or CD-RW media devices.

You can use the `cdwr` command to:

- Create data CDs
- Create audio CDs
- Extract audio data from an audio CD
- Copy CDs
- Erase CD-RW media

The `cdwr` command is available on the Software Supplement for the Solaris 8 Operating Environment 1/01 CD and is also part of the Solaris 9 release.

For information on recommended CD-R or CD-RW devices, go to http://www.sun.com/io_technologies/pci/removable.html.

CD Media Commonly Used Terms

Commonly used terms when referring to CD media are:

Term	Description
CD-R	CD read media that can be written once and after that, can only be read from.
CD-RW	CD rewritable media that can be written to and erased. CD-RW media can only be read by CD-RW devices.
ISO 9660	ISO, an acronym for Industry Standards Organization, is an organization that sets standards computer storage formats. An ISO 9660 file system is a standard CD-ROM file system that enables you to read the same CD-ROM on any major computer platform. The standard, issued in 1988, was written by an industry group named High Sierra, named after the High Sierra Hotel in Nevada. Almost all computers with CD-ROM drives can read files from an ISO 9660 file system.
Joliet extensions	Adds Windows™ file system information.
Rock Ridge extensions	Adds UNIX™ file system information. (Rock Ridge is named after the town in Blazing Saddles.) Note – These extensions are not exclusive. You can specify both <code>mkisofs -R</code> and <code>-j</code> options for compatibility with both systems. (See <code>mkisofs(1M)</code> for details.)
MMC-compliant record	Acronym for Multi Media Command, which means these recorder comply with a common command set. Programs that can write to one MMC-compliant recorder should be able to write to all others.
Red Book CDDA	Acronym for Compact Disc Digital Audio, which is an industry standard method for storing digital audio on compact discs. It is also known by the term “Red Book” format. The official industry specification calls for one or more audio files sampled in 16-bit stereo sound at a sampling rate of 44.1 kilohertz (kHz).

Commonly used terms when working with the CD media are:

Term	Description
blanking	The process of erasing data from the CD-RW media.
mkisofs	Command for making a ISO file system to write onto a CD.
session	A complete track with lead-in and lead-out information.
track	A complete data or audio unit.

Writing Data and Audio CDs

The process of writing to a CD cannot be interrupted and needs a constant stream of data. Consider using the `cdwr -S` option to simulate writing to the media to verify if the system can provide data at a rate good enough for writing to the CD.

Write errors can be caused by one of the following:

- The media cannot handle the drive speed. For example, some media are only certified for 2x or 4x speeds.
- The system is running too many heavy processes that can starve the writing process.
- Network congestion can cause delays in reading the image if the image is on a remote system.
- The source drive might be slower than the destination drive when copying from CD-to-CD.

If any of these problems occur, you can lower the writing speed of the device with the `cdwr -p` option.

For example, simulate writing at 4x speed.

```
$ cdwr -iS -p 4 image.iso
```

You can also use the `cdwr -C` option to use the stated media capacity for copying an 80-minute CD. Otherwise, the `cdwr` command uses a default value of 74 minutes for copying an audio CD.

For more information, see `cdwr(1)`.

Restricting User Access to Removable Media with RBAC

By default, all users can access removable media starting in the Solaris 9 release. However, you can restrict user access to removable media by setting up a role through role based access control (RBAC). Access to removable media is restricted by assigning the role to a limited set of users.

For a discussion of using roles, see “RBAC Roles” in *System Administration Guide: Security Services*.

▼ How to Restrict User Access to Removable Media with RBAC

1. **Become superuser or assume an equivalent role.**
2. **Start the Solaris Management Console.**

```
$ /usr/sadm/bin/smc &
```

For more information on starting the console, see “How to Start the Solaris Management Console in a Name Service Environment” on page 61.

3. **Set up a role that includes the Device Management rights.**

For more information, see “How to Create a Role by Using the Administrative Roles Tool” in *System Administration Guide: Security Services*.

4. **Add users who need to use the `cdrw` command to the newly created role.**
5. **Comment the following line in the `/etc/security/policy.conf` file.**

```
AUTHS_GRANTED=solaris.device.cdrw
```

If you do not do this step, all users still have access to the `cdrw` command, not just the members of the device management role.

After this file is modified, the device management role members are the only users who can use the `cdrw` command. Everyone else is denied access with the following message:

```
Authorization failed, Cannot access disks.
```

How to Identify a CD Writer

Use the `cdrw -l` command to identify the CD writers on the system.

```
$ cdrw -l
Looking for CD devices...
Node           | Connected Device           | Device type
```

Creating a Data CD

Prepare the data first by using the `mkisofs` command to convert the file and file information into the High Sierra format used on CDs.

▼ How to Create an ISO 9660 File System for a Data CD

1. Insert a blank CD into the CD-RW device.
2. Create the ISO 9660 file system on the new CD.

```
$ mkisofs -r /pathname > cd-file-system
```

<code>-r</code>	Creates Rock Ridge information and resets file ownerships to zero.
<code>/pathname</code>	Identifies the pathname used to create the ISO 9660 file system.
<code>> cd-file-system</code>	Identifies the name of the file system to be put on the CD.

3. Copy the CD file system onto the CD.

```
$ cdrw -i cd-file-system
```

<code>-i cd-file-system</code>	Specifies the image file for creating a data CD.
--------------------------------	--

Example—Creating an ISO 9660 File System for a Data CD

The following example shows how to create a ISO 9660 file system for a data CD.

```
$ mkisofs -r /home/dubs/ufs_dir > ufs_cd
Total extents actually written = 56
Total translation table size: 0
Total rockridge attributes bytes: 329
Total directory bytes: 0
Path table size(bytes): 10
Max brk space used 8000
56 extents written (0 Mb)
```

Then copy the CD file system onto the CD. For example:

```
$ cdrw -i ufs_cd
Initializing device...done.
Writing track 1...done.
```

Finalizing (Can take several minutes)...done.

▼ How to Create a Multi-Session Data CD

This procedure describes how to put more than one session on the CD. This procedure includes an example of copying the `infoA` and `infoB` directories onto the CD.

1. Create the file system for the first CD session.

```
$ mkisofs -o infoA -r -V my_infoA /data/infoA
Total translation table size: 0
Total rockridge attributes bytes: 24507
Total directory bytes: 34816
Path table size(bytes): 98
Max brk space used 2e000
8929 extents written (17 Mb)
```

<code>-o infoA</code>	Identifies the name of the ISO file system.
<code>-r</code>	Creates Rock Ridge information and resets file ownerships to zero.
<code>-V my_infoA</code>	Identifies a volume label to be used as the mount point by <code>void</code> .
<code>/data/infoA</code>	Identifies the ISO image directory to create.

2. Copy the ISO file system for the first session onto the CD.

```
$ cdrw -iO infoA
Initializing device...done.
Writing track 1...done.
done.
Finalizing (Can take several minutes)...done.
```

<code>-i infoA</code>	Identifies the name of the image file to write to the CD.
<code>-O</code>	Keeps the CD open for writing.

3. Re-insert the CD after it is ejected.

4. Identify the pathname of the CD media to include in the next write session.

```
$ eject -n
.
.
.
cdrom0 -> /vol/dev/rdisk/c2t4d0/my_infoA
```

Note the `/vol/dev/...` pathname.

5. Identify the next writeable address on the CD to write the next session.

```
% cdrw -M /cdrom
Device : YAMAHA CRW8424S
Firmware : Rev. 1.0d (06/10/99)

Track No. |Type      |Start address
-----+-----+-----
1          |Audio     |0
2          |Audio     |33057
3          |Data      |60887
4          |Data      |68087
5          |Data      |75287
Leadout    |Data      |84218
```

```
Last session start address: 75287
Next writable address: 91118
```

Note the address in the Next writable address: output so you can provide this when you write the next session.

6. Create the next ISO file system for the next CD session and write it onto the CD.

```
$ mkisofs -o infoB -r -C 0,91118 -M /vol/dev/rdisk/c2t4d0/my_infoA
/data/infoB
Total translation table size: 0
Total rockridge attributes bytes: 16602
Total directory bytes: 22528
Path table size(bytes): 86
Max brk space used 20000
97196 extents written (189 Mb)
```

- | | |
|--|---|
| <code>-o infoB</code> | Identifies the name of the ISO file system. |
| <code>-r</code> | Creates Rock Ridge information and resets file ownerships to zero. |
| <code>-C 0,91118</code> | Identifies the starting address of the first session and the next writable address. |
| <code>-M /vol/dev/rdisk/c2t4d0/my_infoA</code> | Specifies the path of the existing ISO image to be merged. |
| <code>/data/infoB</code> | Identifies the ISO image directory to create. |

Creating an Audio CD

You can use the `cdrw` command to create audio CDs from individual audio tracks or from `.au` and `.wav` files.

The supported audio formats are:

Format	Description
sun	Sun .au files with data in Red Book CDDA format
wav	RIFF (.wav) files with data in Red Book CDDA format
cda	.cda files with raw CD audio data, which is 16-bit PCM stereo at 44.1 kHz sample rate in little-endian byte order)
aur	.aur files with raw CD data in big-endian byte order

If no audio format is specified, the `cdwr` command tries to determine the audio file format based on the file extension. The case of the characters in the extension is ignored.

▼ How to Create an Audio CD

This procedure describes how to copy audio files onto a CD.

1. **Insert a blank CD into the CD-RW device.**
2. **Change to the directory that contains the audio files.**

```
$ cd /myaudiodir
```

3. **Copy the audio files onto the CD.**

```
$ cdwr -a track1.wav track2.wav track3.wav
```

The `-a` option creates an audio CD.

Examples—Creating an Audio CD

The following example shows how to create an audio CD.

```
$ cdwr -a bark.wav chirp.au meow.wav
Initializing device...done.
Writing track 1...done.
done.
Writing track 2...done.
Writing track 3...done.
done.
Finalizing (Can take several minutes)...done.
```

The following example shows how to create a multisession audio CD. The CD is ejected after the first session is written. Re-insert the CD before the next writing session.

```
$ cdwr -a0 groucho.wav chico.au harpo.wav
Initializing device...done.
Writing track 1...done.
```

```

done.
Writing track 2...done.
Writing track 3...done.
done.
Finalizing (Can take several minutes)...done.
<Re-insert CD>
$ cdwr -a zeppo.au
Initializing device...done.
Writing track 1...done.
done.
Finalizing (Can take several minutes)...done.

```

▼ How to Extract an Audio Track on a CD

Use the following procedure to extract an audio track from a CD and copy it to a new CD.

If you don't use the `cdwr -T` option to specify the audio file type, `cdwr` uses the filename extension to determine the audio file type. For example, the `cdwr` command detects that this file is a `.wav` file.

```
$ cdwr -x 1 testme.wav
```

1. **Insert a audio CD into the CD-RW device.**
2. **Extract an audio track.**

```
$ cdwr -x -T audio-type 1 audio-file
```

`-x`

Extracts audio data from an audio CD.

`T audio-type`

Identifies the type of audio file to be extracted. Supported audio types are `sun`, `wav`, `cda`, or `aur`.

3. **Copy the track to a new CD.**

```
$ cdwr -a audio-file
```

Examples—Extracting and Creating Audio CDs

The following example shows how to extract the first track from an audio CD and names the file `song1.wav`.

```
$ cdwr -x -T wav 1 song1.wav
Extracting audio from track 1...done.
```

This example describes how to copy a track to an audio CD.

```
$ cdrw -a song1.wav
Initializing device...done.
Writing track 1...done.
Finalizing (Can take several minutes)...done.
```

▼ How to Copy a CD

This procedure describes how to extract all the tracks from an audio CD into a directory and then copy all them onto a blank CD.

Note – By default, the `cdrw` command copies the CD into the `/tmp` directory. The copying might require up to 700 Mbytes of free space. If there is insufficient space in the `/tmp` directory for copying the CD, use the `-m` option to specify an alternate directory.

1. **Insert an audio CD into a CD-RW device.**
2. **Extract the tracks from the audio CD.**

```
$ mkdir music_dir
$ cdrw -c -m music_dir
```

An `Extracting audio . . .` message is display for each track.
The CD is ejected when all the tracks are extracted.

3. **Insert a blank CD and press Return.**

After the tracks are extracted, the audio CD is ejected, and you are prompted to insert a blank CD.

Example—Copying a CD

This example describes how to copy one CD to another CD. You must have two CD-RW devices to do this task.

```
$ cdrw -c -s cdrom0 -d cdrom1
```

▼ How to Erase CD-RW Media

You have to erase existing CD-RW data before the CD can be rewritten.

1. **Erase the entire media or just the last session on the CD by selecting one of the following:**
 - a. **Erase the last session only.**

```
$ cdrw -d cdrom0 -b session
```

Erasing just the last session with the `-b session` option is faster than erasing the entire media with the `-b all` option. You can use the `-b session` option even if you used the `cdrw` command to create a data or audio CD in just one session.

b. Erase the entire media.

```
$ cdrw -d cdrom0 -b all
```

Managing Software Topics

This topic map lists the chapters that provide information on managing software in the Solaris environment.

Chapter 22	Provides overview information about adding and removing software products.
Chapter 23	Provides step-by-step instructions for adding and removing software packages.
Chapter 24	Provides overview information about managing Solaris patches.
Chapter 25	Provides step-by-step instructions for managing Solaris patches.

Managing Software (Overview)

The management of software involves adding and removing software from standalone systems, servers, and their clients. This chapter describes background and other information about the various tools available for installing and managing software.

This chapter does not describe installing the Solaris software on a new system, nor does it describe installing or upgrading a new version of the Solaris software. For information on installing or upgrading Solaris software, see *Solaris 9 12/03 Installation Guide*.

This is a list of the overview information in this chapter.

- “What’s New in Software Management in the Solaris 9 Update Releases” on page 271
- “What’s New in Software Management in the Solaris 9 Release?” on page 272
- “Where to Find Software Management Tasks” on page 274
- “Overview of Software Packages” on page 274
- “Tools for Managing Software Packages” on page 280
- “Adding or Removing a Software Package (pkgadd)” on page 281
- “Key Points for Adding Software Packages (pkgadd)” on page 281
- “Guidelines for Removing Packages (pkgrm)” on page 282
- “Avoiding User Interaction When Adding Packages (pkgadd)” on page 283

For step-by-step instructions on managing software, see Chapter 23.

What’s New in Software Management in the Solaris 9 Update Releases

This section describes a new software management feature in this Solaris release.

pkgadd and patchadd Support for Signed Packages and Patches

Solaris 9 12/03 –This Solaris release enables you to securely download Solaris packages and patches that include a digital signature by using the updated `pkgadd` and `patchadd` commands.

In previous Solaris releases, you could download the Solaris patch management tools and use the `smpatch` command with PatchPro to manage signed patches. For step-by-step instructions on using the `smpatch` command to manage signed patches, see “Preparation for Managing Signed Patches with `smpatch` Command (Task Map)” on page 343.

For step-by-step instructions on using the `patchadd` command to add signed patches, see “Adding Signed Patches With `patchadd` Command (Task Map)” on page 339.

For step-by-step instructions on using the `pkgadd` command to add signed packages, see “Adding and Removing Signed Packages (Task Map)” on page 311.

prodreg Command Enhancements

Solaris 9 4/03 –You can now use several options to the `prodreg` command to access and manage the Solaris Product Registry from the command line.

For information on using the `prodreg` command to administer software packages, see “Managing Software With the Solaris Product Registry Command-Line Interface (Task Map)” on page 292.

What’s New in Software Management in the Solaris 9 Release?

This section describes new software management features in the Solaris 9 release.

Signed Patches

All patches that are available for the Solaris 2.6, 7, 8, and 9 releases include a digital signature. A valid digital signature ensures that the patch has not been modified since the signature was applied.

Using signed patches is a secure method of downloading or applying patches because the patches include a digital signature that can be verified before the patch is applied to your system.

Signed patches are stored in Java™ archive format files (*abc.jar*) and are available from the SunSolve OnlineSM Web site.

For information about adding signed patches with the `smpatch` command, see “Preparation for Managing Signed Patches with `smpatch` Command (Task Map)” on page 343. For troubleshooting problems with the `smpatch` command, go to <http://sunsolve.Sun.COM/pub-cgi/show.pl?target=patches/spfaq>.

Solaris Product Registry 3.0

The Solaris Product Registry 3.0 is a GUI tool that enables you to install and uninstall software packages.

For information on using this product to manage software packages, see “Managing Software With the Solaris Product Registry GUI (Task Map)” on page 288.

Patch Analyzer

When you use the Solaris™ Web Start program to upgrade to a Solaris 9 Update Release, the patch analyzer performs an analysis on your system to determine which (if any) patches will be removed or downgraded by upgrading to the Solaris Update Release. You do not need to use the Patch Analyzer when you upgrade to the Solaris 9 release.

For information on using this tool when you are upgrading to a Solaris 9 update release, see “Upgrading to a Solaris Update Release (Tasks)” in *Solaris 9 12/03 Installation Guide*.

Solaris Management Console Patch Manager

The Solaris Management Console provides a new Patches Tool for managing patches. You can only use the Patches Tool to add patches to a system running the Solaris 9 release.

For information on starting the Solaris Management Console, see “How to Start the Console as Superuser or as a Role” on page 54.

Where to Find Software Management Tasks

Use this table to find step-by-step instructions for managing software.

Software Management Topics	For More Information
Installing Solaris software	<i>Solaris 9 12/03 Installation Guide</i>
Adding or removing Solaris software packages after installation	Chapter 23
Adding or removing Solaris patches after installation	Chapter 25
Troubleshooting software package problems	“Troubleshooting Software Package Problems (Tasks)” in <i>System Administration Guide: Advanced Administration</i>

Overview of Software Packages

Software management involves installing or removing software products. Sun and its third-party vendors deliver software products in a form called a *package*.

The term *packaging* generically refers to the method for distributing and installing software products to systems where the products will be used. A package is a collection of files and directories in a defined format. This format conforms to the application binary interface (ABI), which is a supplement to the System V Interface Definition. The Solaris operating environment provides a set of utilities that interpret this format and provide the means to install a package, to remove a package, or to verify a package installation.

A *patch* is a collection of files and directories that replace or update existing files and directories that are preventing proper execution of the existing software. For more information about patches, see Chapter 24.

Signed Packages and Patches

Packages can include a digital signature. A package with a valid digital signature ensures that the package has not been modified since the signature was applied to the package. Using signed packages is a secure method of downloading or adding packages because the digital signature can be verified before the package is added to your system.

The same holds true for signed patches. A patch with a valid digital signature ensures that the patch has not been modified since the signature was applied to the patch. Using signed patches is a secure method of downloading or adding patches because the digital signature can be verified before the patch is added to your system.

For more information about *adding* signed patches to your system, see “Adding Signed Patches With `patchadd` Command (Task Map)” on page 339.

For information about *creating* signed packages, see *Application Packaging Developer’s Guide*.

A signed package is identical to an unsigned package, except for the digital signature. The package can be installed, queried, or removed with existing Solaris packaging tools. A signed package is also binary-compatible with an unsigned package.

Before you can add a package or patch with a digital signature to your system, you must set up a package keystore with trusted certificates. These certificates are used to identify that the digital signature on the package or patch is valid.

The following table describes the general terms associated with signed packages and patches.

Term	Definition
Keystore	<p>A repository of certificates and keys that is queried when needed.</p> <ul style="list-style-type: none">■ Java keystore – A repository of certificates that is installed by default with the Solaris release. The Java keystore is usually stored in the <code>/usr/j2se/jre/lib/security</code> directory.■ Package keystore – A repository of certificates that you import when adding signed packages and patches to your system. The package keystore is stored in the <code>/var/sadm/security</code> directory by default.

Term	Definition
Trusted certificate	<p>A certificate that holds a public key that belongs to another entity. The <i>trusted certificate</i> is named as such because the keystore owner trusts that the public key in the certificate indeed belongs to the identity identified by the subject or owner of the certificate. The issuer of the certificate vouches for this trust by signing the certificate.</p> <p>Trusted certificates are used when verifying signatures, and when initiating a connection to a secure (SSL) server.</p>
User key	<p>Holds sensitive cryptographic key information. This information is stored in a protected format to prevent unauthorized access. A user key consists of both the user's private key and the public key certificate that corresponds to the private key.</p>

The process of adding a signed package or patch to your system involves three basic steps:

1. Adding the certificates to your system's package keystore with the `pkgadm` command
2. (Optional) Listing the certificates with the `pkgadm` command
3. Adding the package with the `pkgadd` command or adding the patch with the `patchadd` command

For step-by-step instructions on adding signed packages to your system, see "Adding and Removing Signed Packages (Task Map)" on page 311. For step-by-step instructions on adding signed patches to your system, see "Adding Signed Patches With `patchadd` Command (Task Map)" on page 339.

Using Sun's Certificates to Verify Signed Packages and Patches

A *stream-formatted SVR4*-signed package or patch contains an embedded PEM-encoded PKCS7 signature. This signature contains at a minimum the encrypted digest of the package or patch, along with the signer's X.509 public key certificate. The package or patch can also contain a *certificate chain* that is used to form a chain of trust from the signer's certificate to a locally stored trusted certificate.

The PEM-encoded PKCS7 signature is used to verify the following:

- The package came from the entity that signed it.
- The entity indeed signed it.
- The package hasn't been modified since the entity signed it.
- The entity that signed it is a trusted entity.

The following table describes the encryption terminology associated with signed packages and patches.

Term	Definition
ASN.1	Abstract Syntax Notation 1 (ASN.1) is a way to express a set of abstract objects. For example, ASN.1 defines a public key certificate, all of the objects that make up the certificate, and the order in which the objects are collected. However, ASN.1 does not specify how the objects are serialized for storage or transmission.
base64	base64 is a method of encoding arbitrary binary data as ASCII text.
DER	Distinguished Encoding Rules (DER) is a binary representation of an ASN.1 object. DER defines how an ASN.1 object is serialized for storage or transmission in computing environments.
PEM	The Privacy Enhanced Message (PEM) is a way to encode a file (in DER or other binary format) using base64 encoding and some optional headers. Initially used for encoding MIME-type email messages. PEM is also used extensively for encoding certificates and private keys into a file that exists on a file system or in an email message.
PKCS7	The Public Key Cryptography Standard #7 (PKCS7) describes a general syntax for data that may have cryptography applied to it, such as digital signatures and digital envelopes.
X.509	<p>The International Telecommunication Union-Telcom (ITU-T) recommendation X.509 specifies the widely adopted X.509 public key certificate syntax.</p> <p>This recommendation defines a framework for the provision of authentication services. X.509 describes two levels of authentication:</p> <ul style="list-style-type: none"> ■ Simple authentication – using a password as a verification of claimed identity. ■ Strong authentication – involving credentials formed using cryptographic techniques. While simple authentication offers some limited protection against unauthorized access, use only strong authentication as the basis for providing secure services.

Digital certificates, issued and authenticated by Sun Microsystems, are used to verify that the downloaded package or patch with the digital signature has not been compromised. These certificates are imported into your system's keystore.

All Sun certificates are issued by Baltimore Technologies, which recently bought GTE CyberTrust.

Access to a keystore is protected by a special password that you specify when you import the Sun certificates into your system's keystore.

If you use the `pkgadm listcert` command, you can view information about your locally stored certificates in the package keystore. For example:

```
# pkgadm listcert -P pass:store-pass
  Keystore Alias: GTE CyberTrust Root
    Common Name: GTE CyberTrust Root
  Certificate Type: Trusted Certificate
  Issuer Common Name: GTE CyberTrust Root
    Validity Dates: <Feb 23 23:01:00 1996 GMT> - <Feb 23 23:59:00 2006 GMT>
    MD5 Fingerprint: C4:D7:F0:B2:A3:C5:7D:61:67:F0:04:CD:43:D3:BA:58
    SHA1 Fingerprint: 90:DE:DE:9E:4C:4E:9F:6F:D8:86:17:57:9D:D3:91:BC:65:A6...
```

The following table describes the output of the `pkgadm listcert` command.

Field	Description
Keystore Alias	When you retrieve certificates for printing, signing, or removing, this name must be used to reference the certificate.
Common Name	The common name of the certificate. For trusted certificates, this name is the same as the keystore alias.
Certificate Type	Can be one of two types: <ul style="list-style-type: none">■ Trusted Certificate - A certificate that can be used as a trust anchor when verifying other certificates. No private key is associated with a trusted certificate.■ Signing Certificate - A certificate that can be used when signing a package or patch. A private key is associated with a signing certificate.
Issuer Common Name	The name of the entity that issued, and therefore signed, this certificate. For trusted certificate authority (CA) certificates, the issuer common name and common name are the same.
Validity Dates	A date range that identifies when the certificate is valid.
MD5 Fingerprint	An MD5 digest of the certificate. This digest can be used to verify that the certificate has not been altered during transmission from the source of the certificate.
SHA1 Fingerprint	Similar to an MD5 Fingerprint, except that it is calculated using a different algorithm.

Each certificate is authenticated by comparing its MD5 and SHA1 hashes, also called *fingerprints*, against the known correct fingerprints published by the issuer.

SunSolve Online's Trusted Certificates

SunSolve Online uses the following certificates to verify the digital signatures on signed patches with the previous Solaris patch management tools (`smpatch` command), including PatchPro:

- Top-level certificate, called the Root Certificate Authority (CA)
- A subordinate CA, which is the Sun Microsystems Inc., CA Class B certificate.
- An additional certificate issued by Sun Enterprise™ Services, called the *patch management certificate*

A *certificate authority* certifies the relationship between public keys that are used to decrypt the digital signature with the patch and the owner of the public keys.

The Sun Root CA, Sun Class B CA, and the patch signing certificate are included with the Solaris patch management tools, including PatchPro. These three certificates provide a certificate chain of trust in the patch verification process whereby the Sun Root CA trusts the Class B CA, and the Class B CA trusts the patch management certificate. And, ultimately, the GTE CyberTrust CA trusts the Sun Root CA.

Importing Sun's Trusted Certificates

You can obtain Sun's trusted certificates for adding signed packages and patches in the following ways:

- **Java keystore** – Import Sun's Root CA certificate that is included by default in the Java keystore when you install the Solaris release.
- **Sun's Public Key Infrastructure (PKI) site** – If you do not have a Java keystore available on your system, you can import the certificates from this site.
<https://ra.sun.com:11005/>
- **PatchPro's keystore** – If you have installed PatchPro for adding signed patches with the `smpatch` command, you can import Sun's Root CA certificate from the Java keystore.

Setting Up a Package Keystore

In previous Solaris releases, you could download the patch management tools and create a Java keystore, for use by PatchPro, by importing the certificates with the `keytool` command.

If your system already has a populated Java keystore, you can now export the Sun Microsystems root CA certificate from the Java keystore with the `keytool` command. Then, use the `pkgadm` command to import this certificate into the package keystore.

After the Root CA certificate is imported into the package keystore, you can use the `pkgadd` and `patchadd` commands to add signed packages and patches to your system.

Note – The Sun Microsystems root-level certificates are only required when adding Sun-signed patches and packages.

For step-by-step instructions on importing certificates into the package keystore, see “How to Import a Trusted Certificate into the Package Keystore (`pkgadm addcert`)” on page 311.

For complete instructions on adding signed packages with the `pkgadd` command, see “Adding and Removing Signed Packages (Task Map)” on page 311.

Tools for Managing Software Packages

The tools for adding and removing software packages from a system after the Solaris release is installed on a system are the following:

TABLE 22-1 Software Package Tools

Add, Remove, and Display Software Package Information With This Tool	Additional Features
The Solaris Web Start program	Launch an installer to add products included in the Solaris 9 media pack. You cannot add individual software packages.
Solaris Product Registry (GUI)	Launch an installer to add, remove, or display software product information. Use Product Registry to remove or display information about software products that were originally installed by using the Solaris Web Start program or the Solaris <code>pkgadd</code> command.
Solaris Product Registry <code>prodreg</code> Viewer (command line interface)	Use the <code>prodreg</code> command to remove or display information about software products that were originally installed by using the Solaris Web Start program or the Solaris <code>pkgadd</code> command.

TABLE 22–1 Software Package Tools (Continued)

Add, Remove, and Display Software Package Information With This Tool	Additional Features
Package commands (<code>pkgadd</code> , <code>pkgrm</code> , <code>pkginfo</code>)	Incorporate these commands into scripts, set up optional files to avoid user interaction or perform special checks, and copy software packages to spool directories.

Adding or Removing a Software Package (`pkgadd`)

All the software management tools that are listed in Table 22–1 are used to add, remove, or query information about installed software. `Admintool`, the Solaris Product Registry `prodreg` viewer, and the Web Start program all access install data that is stored in the Solaris Product Registry. The package tools, such as the `pkgadd` and `pkgrm` commands, also access or modify install data.

When you add a package, the `pkgadd` command uncompresses and copies files from the installation media to a local system’s disk. When you remove a package, the `pkgrm` command deletes all files associated with that package, unless those files are also shared with other packages.

Package files are delivered in package format and are unusable as they are delivered. The `pkgadd` command interprets the software package’s control files, and then uncompresses and installs the product files onto the system’s local disk.

Although the `pkgadd` and `pkgrm` commands do not log their output to a standard location, they do keep track of the product that is installed or removed. The `pkgadd` and `pkgrm` commands store information about a package that has been installed or removed in a software product database.

By updating this database, the `pkgadd` and `pkgrm` commands keep a record of all software products installed on the system.

Key Points for Adding Software Packages (`pkgadd`)

Keep the following key points in mind before you install or remove packages on your system:

- Package naming conventions – Sun packages always begin with the prefix `SUNW`, as in `SUNWaccr`, `SUNWadmap`, and `SUNWcsu`. Third-party packages usually begin with a prefix that corresponds to the company’s stock symbol.
- What software is already installed – You can use the Web Start program, Solaris Product Registry `prodreg` viewer (either GUI or CLI), `Admintool`, or the `pkginfo` command to determine the software that is already installed on a system.
- How servers and clients share software – Clients might have software that resides partially on a server and partially on the client. In such cases, adding software for the client requires that you add packages to both the server and the client.

Guidelines for Removing Packages (`pkgrm`)

You should use one of these tools to remove a package, even though you might be tempted to use the `rm` command instead. For example, you could use the `rm` command to remove a binary executable file, but that is not the same as using the `pkgrm` command to remove the software package that includes that binary executable. Using the `rm` command to remove a package’s files will corrupt the software products database. If you really only want to remove one file, you can use the `removef` command, which will update the software product database correctly so that the file is no longer a part of the package. For more information, see `removef(1M)`.

If you intend to keep multiple versions of a package (for example, multiple versions of a document processing application), install new versions into a different directory than the already installed package with the `pkgadd` command. The directory where a package is installed is referred to as the base directory. You can manipulate the base directory by setting the `basedir` keyword in a special file called an administration file. For more information on using an administration file and on setting the base directory, see “Avoiding User Interaction When Adding Packages (`pkgadd`)” on page 283 and `admin(4)`.

Note – If you use the upgrade option when installing the Solaris software, the Solaris installation software consults the software product database to determine the products that are already installed on the system.

Avoiding User Interaction When Adding Packages (pkgadd)

Using an Administration File

When you use the `pkgadd -a` command, the command consults a special administration file for information about how the installation should proceed. Normally, the `pkgadd` command performs several checks and prompts the user for confirmation before it actually adds the specified package. You can, however, create an administration file that indicates to the `pkgadd` command that it should bypass these checks and install the package without user confirmation.

The `pkgadd` command, by default, checks the current working directory for an administration file. If the `pkgadd` command doesn't find an administration file in the current working directory, it checks the `/var/sadm/install/admin` directory for the specified administration file. The `pkgadd` command also accepts an absolute path to the administration file.



Caution – Use administration files judiciously. You should know where a package's files are installed and how a package's installation scripts run before using an administration file to avoid the checks and prompts that the `pkgadd` command normally provides.

The following example shows an administration file that will prevent the `pkgadd` command from prompting the user for confirmation before installing the package.

```
mail=
instance=overwrite
partial=nocheck
runlevel=nocheck
idepend=nocheck
rdepend=nocheck
space=nocheck
setuid=nocheck
conflict=nocheck
action=nocheck
basedir=default
```

Besides using administration files to avoid user interaction when you add packages, you can use them in several other ways. For example, you can use an administration file to quit a package installation (without user interaction) if there's an error or to avoid interaction when you remove packages with the `pkgrm` command.

You can also assign a special installation directory for a package, which you might do if you wanted to maintain multiple versions of a package on a system. To do so, set an alternate base directory in the administration file (by using the `basedir` keyword), which specifies where the package will be installed. For more information, see `admin(4)`.

Using a Response File (`pkgadd`)

A response file contains your answers to specific questions that are asked by an *interactive package*. An interactive package includes a `request` script that asks you questions prior to package installation, such as whether or not optional pieces of the package should be installed.

If prior to installation, you know that the package you want to install is an interactive package, and you want to store your answers to prevent user interaction during future installations of this package, you can use the `pkgask` command to save your response. For more information on this command, see `pkgask(1M)`.

Once you have stored your responses to the questions asked by the `request` script, you can use the `pkgadd -r` command to install the package without user interaction.

Managing Software (Tasks)

This chapter describes how to add, verify, and remove software packages.

For information on the procedures associated with performing software management tasks, see:

- “How to Install Software With the Solaris Web Start Program” on page 287
- “Managing Software With the Solaris Product Registry GUI (Task Map)” on page 288
- “Managing Software With the Solaris Product Registry Command-Line Interface (Task Map)” on page 292
- “Adding and Removing Signed Packages (Task Map)” on page 311
- “Managing Software Packages With Package Commands (Task Map)” on page 316
- “Adding and Removing Software Packages With Admintool (Task Map)” on page 325

Commands for Managing Software Packages

The following table lists the commands to use for adding, removing, and checking the installation of software packages after the Solaris release is installed.

TABLE 23-1 Tools or Commands for Managing Software Packages

Tool or Command	Man Page	Description
admintool	admintool(1M)	Installs or removes a software package with a graphical tool.

TABLE 23-1 Tools or Commands for Managing Software Packages (Continued)

Tool or Command	Man Page	Description
<code>installer</code>	<code>installer(1M)</code>	Installs or removes a software package with an installer.
<code>pkgadd</code>	<code>pkgadd(1M)</code>	Installs a signed or unsigned software package.
<code>pkgadm</code>	<code>pkgadm(1M)</code>	Maintains the keys and certificates used to manage signed packages and signed patches.
<code>pkgchk</code>	<code>pkgchk(1M)</code>	Checks the installation of a software package.
<code>pkginfo</code>	<code>pkginfo(1)</code>	Lists software package information.
<code>pkgparam</code>	<code>pkgparam(1)</code>	Displays software package parameter values.
<code>pkgrm</code>	<code>pkgrm(1M)</code>	Removes a software package.
<code>prodreg</code>	<code>prodreg(1M)</code>	Browse, unregister, and uninstall software in the Solaris Product Registry.
<code>pkgtrans</code>	<code>pkgtrans(1)</code>	Translates an installable package from one format to another format. The <code>-g</code> option instructs the <code>pkgtrans</code> command to generate and store a signature in the resulting data stream.

Adding Software With the Solaris Web Start Program

This section describes how to use the Solaris Web Start program to add software to a system on which you have installed the Solaris operating environment. The Solaris Web Start program installs only the components of the software groups that you skipped when you initially installed the Solaris operating environment. You cannot upgrade to another software group after installing or upgrading. For a description of the four software groups, see *Solaris 9 12/03 Installation Guide*.

▼ How to Install Software With the Solaris Web Start Program

Note – This procedure assumes that the system is running volume management (`vol`). If your system is not running volume management, see Chapter 18 for information on accessing removable media without volume management.

1. Become superuser or assume an equivalent role.

2. Decide to install from a CD, a DVD, or from the network. Select one of the following:

- If you are installing from a CD, insert the CD into the CD-ROM drive.
If you insert the Solaris 9 Languages CD, the Solaris Web Start program starts automatically. Proceed to Step 6.
- If you are installing from a DVD, insert the DVD into the DVD-ROM drive.
- If you are installing from the network, locate the net image of the software you want to install.

3. Change directories to find the Solaris Web Start installer.

Solaris Web Start installers are located in various directories on the CDs and on the DVD.

- Solaris 9 Software 1 of 2 CD.
- Solaris 9 Software 2 of 2 CD.
- Solaris 9 Documentation CD.
- Solaris 9 Languages CD. The Solaris Web Start program automatically starts when the CD is inserted.

For specific information about CD and DVD structures, see “Organization of Solaris 9 Media (Reference)” in *Solaris 9 12/03 Installation Guide*.

4. Follow the instructions to install the software.

- From a file manager, double-click `Installer` or `installer`.
- From the command line, type the following:

```
% ./installer [options]
```

```
-nodisplay
```

Runs the installer without a GUI.

`-noconsole`

Runs without any interactive text console device. Use this option with the `-nodisplay` option when you include the `installer` command in a UNIX script for installing software.

Follow the instructions to install the software.

5. Double-click Installer or installer.

An Installer window is displayed, followed by the Solaris Web Start dialog box.

6. Follow the directions on the screen to install the software.

7. When you have finished adding software, click Exit.

The Solaris Web Start program exits.

Managing Software With the Solaris Product Registry GUI (Task Map)

The following task map describes the software management tasks that you can do with the Solaris Product Registry.

Task	Description	For Instructions
View installed or uninstalled software with the Product Registry	You can view installed or uninstalled software with the Product Registry.	"How to View Installed or Uninstalled Software Information With the Product Registry GUI" on page 290
Install software with the Product Registry	You can use Product Registry to find software and launch the Solaris Web Start program, which leads you through the installation of that software.	"How to Install Software With the Product Registry GUI" on page 290
Uninstall software with the Product Registry	You can uninstall software with the Product Registry.	"How to Uninstall Software With the Product Registry GUI" on page 291

The Solaris Product Registry is a tool to help you manage installed software. After you have installed the software, Product Registry provides a list of all the installed software by using the Solaris Web Start program 3.0 or the Solaris `pkgadd` command.

You can use the Solaris Product Registry in a GUI or with a command-line interface (CLI). For more information on how to use the Solaris Product Registry CLI, see “Managing Software With the Solaris Product Registry Command-Line Interface (Task Map)” on page 292.

The Solaris Product Registry GUI interface enables you to do the following:

- View a list of installed and registered software and some software attributes
- View all Solaris system products that you installed in their localized version in the System Software Localizations directory
- Find and launch an installer
- Install additional software products
- Uninstall software and individual software packages

The Solaris Product Registry GUI main window consists of three areas of information:

- Installed, registered, and removed software
- Standard attributes of the currently selected software
- Attributes that are customized and attributes that are internal to the registered software

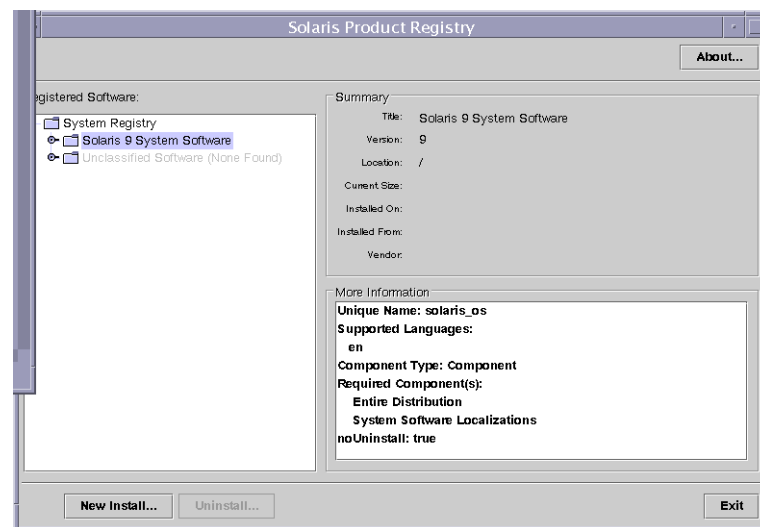

FIGURE 23–1 Solaris Product Registry Window

▼ How to View Installed or Uninstalled Software Information With the Product Registry GUI

1. **Become superuser or assume an equivalent role.**
2. **Start the Product Registry tool.**

```
# prodreg &
```

The Solaris Product Registry main window is displayed.

3. **Click the turner control to the left of the `System registry` directory in the Registered Software box.**

Notice that the turner control changes from pointing to the right to pointing down. You can expand or collapse any item in the Registry, except an item that has a text file icon to its left.

The Software Installed in Registered Software box always contains the following:

- The configuration software group that you chose when installing the Solaris release. Software groups that can be displayed include Core, End User System Support, Developer System Support, Entire Distribution, or Entire Distribution Plus OEM Support.
- Additional system software, which is Solaris products that are not part of the software group you chose.
- Unclassified software, which is any package that you installed by using the `pkgadd` command that is not a Solaris product or part of the software group.

4. **Select directories until you find a software application to view.**

The list expands as you open directories.

5. **To view the attributes, select a directory or file.**

The Product Registry displays attribute information in the System Registry box.

- For software products that were installed with the Solaris Web Start program, the Product Registry contains values for at least the following: Title, Version, Location, and Installed on. Items in an expanded list under a product or software group inherit the version information of the product.
- If all or part of the product was removed with the `pkgrm` command, a cautionary icon appears next to the software product's name.

▼ How to Install Software With the Product Registry GUI

You can use Product Registry to find software and launch the Solaris Web Start program, which leads you through the installation of that software.

1. **Become superuser or assume an equivalent role.**

2. Start the Product Registry tool.

```
# prodreg
```

The Solaris Product Registry window is displayed.

3. Decide if you are installing from a CD, a DVD, or from the network. Select one of the following:

- If you are installing from a CD, insert the CD into the CD-ROM drive.
- If you are installing from a DVD, insert the DVD into the DVD-ROM drive.
- If you are installing from the network, locate the net image of the software that you want to install.

4. To view the list of installed and registered software, click the turner control.

5. Click the New Install button at the bottom of the Solaris Product Registry window.

The Product Registry displays the Select Installer dialog box, which initially points to the `/cdrom` directory or the directory you are in.

6. Select directories to find the Solaris Web Start program installer.

Solaris Web Start installers are located in various directories on the CDs and on the DVD. For specific information about CD and DVD structures, see “Organization of Solaris 9 Media (Reference)” in *Solaris 9 12/03 Installation Guide*.

- Solaris 9 Software 1 of 2 and 2 of 2 CD.
- Solaris 9 Software 2 of 2 CD.
- Solaris 9 Documentation CD.
- Solaris 9 Languages CD. The Solaris Web Start program automatically starts when the CD is inserted.

7. When you find the installer you want, select its name in the Files box.

8. Click OK.

The installer you selected is launched.

9. Follow the directions that are displayed by the installer to install the software.

▼ How to Uninstall Software With the Product Registry GUI

1. Become superuser or assume an equivalent role.

2. Start the Product Registry tool.

```
# prodreg
```

The Solaris Product Registry window is displayed.

3. **To view the list of installed and registered software, click the turner control.**
4. **Select directories until you find the name of the software that you want to uninstall.**
5. **Read the software attributes to make sure that this software is the software that you want to uninstall.**
6. **Click the Uninstall *software-product-name* button at the bottom of the Solaris Product Registry window.**

The software product you selected is uninstalled.

Managing Software With the Solaris Product Registry Command-Line Interface (Task Map)

The following task map describes the software management tasks that you can do with the Solaris Product Registry command-line interface.

Task	Description	For Instructions
View installed or uninstalled software with <code>prodreg</code>	You can view software information with the <code>browse</code> subcommand.	"How to View Installed or Uninstalled Software Information (<code>prodreg</code>)" on page 293
View software attributes with <code>prodreg</code>	You can view specific software attributes with the <code>info</code> subcommand.	"How to View Software Attributes (<code>prodreg</code>)" on page 296
Check dependencies between software components with <code>prodreg</code>	You can view the components that depend on a specific software component with the <code>info</code> subcommand.	"How to Check Dependencies Between Software Components (<code>prodreg</code>)" on page 298
Identify damaged software products with <code>prodreg</code>	If you remove installed software files or packages without using the appropriate uninstaller, you can damage the software on your system.	"How to Identify Damaged Software Products (<code>prodreg</code>)" on page 299

Task	Description	For Instructions
Uninstall software with <code>prodreg</code>	You can remove software from your system with the <code>uninstall</code> subcommand.	"How to Uninstall Software (<code>prodreg</code>)" on page 302
Uninstall damaged software with <code>prodreg</code>	Uninstalling a damaged software component might fail if the uninstaller program for the software component has been removed from the system.	"How to Uninstall Damaged Software (<code>prodreg</code>)" on page 306
Reinstall damaged software components with <code>prodreg</code>	If other software depends on a damaged software component, you might want to reinstall the damaged component, rather than uninstall the component and the other dependent software.	"How to Reinstall Damaged Software Components (<code>prodreg</code>)" on page 309

The `prodreg` command is the command-line interface (CLI) to the Solaris Product Registry. The `prodreg` command supports several subcommands that enable you to manage the software on your system.

You can use the `prodreg` command in a terminal window to perform the following tasks.

- View a list of installed and registered software and software attributes
- View all Solaris system products that you installed in their localized version in the System Software Localizations directory
- Identify damaged software
- Remove software entries from the Solaris Product Registry
- Uninstall software and individual software packages

For more information on how to manage the Solaris Product Registry by using the command-line interface, see the man page `prodreg(1M)`.

▼ How to View Installed or Uninstalled Software Information (`prodreg`)

You can view information about software in the Solaris Product Registry in a terminal window by using the `browse` subcommand to the `prodreg` command.

1. **Open a terminal window.**
2. **Browse the Solaris Product Registry.**

```

% prodreg browse
  BROWSE # +/-/. UUID                               # NAME
  =====
  1      -   root                                   1 System
                                                Registry
  2      +   a01ee8dd-1dd1-11b2-a3f2-0800209a5b6b 1 Solaris 9 4/03
                                                System
                                                Software
  3      +   8f64eabf-1dd2-11b2-a3f1-0800209a5b6b 1 Unclassified
                                                Software

```

The browse subcommand to the prodreg command displays the following information about registered software.

BROWSE #	When you use the <code>prodreg browse</code> command, the Solaris Product Registry generates a browse number for each registered software component. This number can be used as an argument to either the <code>prodreg browse</code> command or the <code>info</code> subcommand to descend the hierarchy of specific registered components.
+/-/.	This field indicates if a software component has additional software component children registered in the Solaris Product Registry. The following characters are displayed in this field. <ul style="list-style-type: none"> ■ + indicates that the software component has additional children components that are not currently displayed. ■ - indicates that the software component has additional children components that are currently displayed. ■ . indicates that the software component does not have children components.
UUID	This field lists the software's unique identifier in the Solaris Product Registry.
#	This field indicates the instance number of the software component on the system. If the system contains multiple instances of a software component, the Solaris Product Registry assigns a separate instance number to each instance of the component.
NAME	This field lists the localized name of the software. The name of the Solaris operating environment in this sample output is the Solaris 9 4/03 release.

3. Browse the information for one of the software components that are listed in the Solaris Product Registry.

```
% prodreg browse -m "name"
```

-m "name" Displays information on the software component with the name *name*

If the system contains multiple instances of *name* software, type the following command to browse the Solaris Product Registry.

```
% prodreg browse -u name-UUID -i instance
```

-u *name-UUID* Displays information on the *name* software component with the unique identifier *name-UUID*

-i *instance* Displays information on *name* software component with the instance number *instance*

4. Repeat Step 3 for each software component you want to browse.

Example—Viewing Software Information by Component Name (prodreg)

The following example shows how to view software information by referencing the component's name.

```
% prodreg browse
BROWSE # +/-/.  UUID                                     #  NAME
===== =====
1          -    root                                     1  System
Registry
2          +    a01ee8dd-1dd1-11b2-a3f2-0800209a5b6b  1  Solaris 9 4/03
System
Software
3          +    8f64eabf-1dd2-11b2-a3f1-0800209a5b6b  1  Unclassified
Software
```

```
% prodreg browse -m "Solaris 9 4/03 System Software"
```

Example—Viewing Software Information by Component Browse Number (prodreg)

The following example shows how to use the *-n* option with the *prodreg browse* command to view software information by referencing the component's browse number.

```

% prodreg browse
  BROWSE # +/-/.  UUID                                     #  NAME
  ===== =====
  1      -      root                                     1  System
                                           Registry
  2      +      a01ee8dd-1dd1-11b2-a3f2-0800209a5b6b  1  Solaris 9 4/03
                                           System
                                           Software
  3      +      8f64eabf-1dd2-11b2-a3f1-0800209a5b6b  1  Unclassified
                                           Software

% prodreg browse -n 2

```

Example—Viewing Software Information by Component UUID (prodreg)

The following example shows how to use the `-u` option with the `prodreg browse` command to view software information by referencing the component's UUID.

```

% prodreg browse
  BROWSE # +/-/.  UUID                                     #  NAME
  ===== =====
  1      -      root                                     1  System
                                           Registry
  2      +      a01ee8dd-1dd1-11b2-a3f2-0800209a5b6b  1  Solaris 9 4/03
                                           System
                                           Software
  3      +      8f64eabf-1dd2-11b2-a3f1-0800209a5b6b  1  Unclassified
                                           Software

% prodreg browse -u a01ee8dd-1dd1-11b2-a3f2-0800209a5b6b

```

▼ How to View Software Attributes (prodreg)

You can view specific software attributes by using the `info` subcommand to the `prodreg` command. The `prodreg info` command displays a variety of information about registered software, including the following items:

- Name of software component
- Software component description
- Required components of the software
- Other components that require the software
- Base directory of the software
- Path to the software component

1. **Open a terminal window.**
2. **Browse the Solaris Product Registry.**

```

% prodreg browse
  BROWSE # +/-/.  UUID                                     # NAME
  ===== =====
  1      -      root                                     1 System
                                                Registry
  2      +      a01ee8dd-1dd1-11b2-a3f2-0800209a5b6b 1 Solaris 9 4/03
                                                System
                                                Software
  3      +      8f64eabf-1dd2-11b2-a3f1-0800209a5b6b 1 Unclassified
                                                Software

```

3. View the attributes for one of the software components that are listed in the Solaris Product Registry.

You can view the attributes for one of the software components that are listed in the output of the `prodreg info` command in the following ways.

```

% prodreg info -m "name"
-m "name"                                     Displays the attributes of the software
                                                component with the name name

```

4. Repeat Step 3 for each software component you want to view.

Example—Viewing Software Attributes by Component Name (prodreg)

The following example shows how to view software attributes by referencing the component's name.

```

% prodreg browse
  BROWSE # +/-/.  UUID                                     # NAME
  ===== =====
  1      -      root                                     1 System
                                                Registry
  2      +      a01ee8dd-1dd1-11b2-a3f2-0800209a5b6b 1 Solaris 9 4/03
                                                System
                                                Software
  3      +      8f64eabf-1dd2-11b2-a3f1-0800209a5b6b 1 Unclassified
                                                Software

% prodreg info -m "Solaris 9 4/03 System Software"

```

Example—Viewing Software Attributes by Component Browse Number (prodreg)

The following example shows how to use the `-n` option with the `prodreg info` command to view software attributes by referencing the component's browse number.

```

% prodreg browse
  BROWSE # +/-/.  UUID                                     #  NAME
  ===== =====
  1      -      root                                     1  System
                                           Registry
  2      +      a01ee8dd-1dd1-11b2-a3f2-0800209a5b6b  1  Solaris 9 4/03
                                           System
                                           Software
  3      +      8f64eabf-1dd2-11b2-a3f1-0800209a5b6b  1  Unclassified
                                           Software

% prodreg info -n 2

```

Example—Viewing Software Attributes by Component UUID (prodreg)

The following example shows how to use the `-u` option with the `prodreg info` command to view software attributes by referencing the component's UUID.

```

% prodreg browse
  BROWSE # +/-/.  UUID                                     #  NAME
  ===== =====
  1      -      root                                     1  System
                                           Registry
  2      +      a01ee8dd-1dd1-11b2-a3f2-0800209a5b6b  1  Solaris 9 4/03
                                           System
                                           Software
  3      +      8f64eabf-1dd2-11b2-a3f1-0800209a5b6b  1  Unclassified
                                           Software

% prodreg info -u a01ee8dd-1dd1-11b2-a3f2-0800209a5b6b

```

▼ How to Check Dependencies Between Software Components (prodreg)

You can use the `prodreg info` command to view the components that depend on a specific software component. You might want to check dependencies between software products before you uninstall specific components.

1. Open a terminal window.
2. Browse the Solaris Product Registry.

```

% prodreg browse
  BROWSE # +/-/.  UUID                                     #  NAME
  ===== =====
  1      -      root                                     1  System
                                           Registry

```

```

2          +          a01ee8dd-1dd1-11b2-a3f2-0800209a5b6b  1  Solaris 9 4/03
                                                System
                                                Software
3          +          8f64eabf-1dd2-11b2-a3f1-0800209a5b6b  1  Unclassified
                                                Software

```

Repeat the `prodreg browse` command until the software component you want to check is displayed in the Solaris Product Registry. See “How to View Installed or Uninstalled Software Information (`prodreg`)” on page 293 for more information on browsing the Solaris Product Registry with the `prodreg browse` command.

3. View the dependencies of a specific software component.

```
% prodreg info -m "name" -a "Dependent Components"
```

`-m "name"` Displays the attributes of the software component with the name *name*.

`-a "Dependent Components"` Displays the components that depend on *name* software by displaying the values of the Dependent Components attribute.

This command outputs a list of the software components that depend on *name* software.

Example—Viewing Components That Depend on Other Software Products (`prodreg`)

The following example shows how to view the components that depend on the software product that is named `ExampleSoft`.

```
% prodreg -m "ExampleSoft" -a "Dependent Components"
Dependent Components:
Name                               UUID                               #
-----
ExampleSoftA                       7f49ecvb-1ii2-11b2-a3f1-0800119u7e8e  1

```

▼ How to Identify Damaged Software Products (`prodreg`)

If you remove installed software files or packages without using the appropriate uninstaller, you can damage the software on your system. If software is damaged, the software might not function properly. You can use the `info` subcommand to the `prodreg` command to help you determine if a software product is damaged.

1. View the Solaris Product Registry information on the software you want to check.

```

% prodreg browse -m name
BROWSE # +/-/. UUID # NAME
=====
1 - root 1 System
Registry
2 + a01ee8dd-1dd1-11b2-a3f2-0800209a5b6b 1 Solaris 9 8/03
System
Software
3 + 8f64eabf-1dd2-11b2-a3f1-0800209a5b6b 1 Unclassified
Software
4 - name-UUID 1 name
233 . component-a-pkg 1 component-a
234 . component-b-pkg 1

```

- m "*name*" Displays information on the software component with the name *name*.
- name-UUID* Specifies the UUID of the *name* software component.
- component-a-pkg* Specifies the package name of the *component-a* component that depends on *name* software.
- component-a* Specifies the name of a component that depends on *name* software.
- component-b-pkg* Specifies the package name of the *component-b* component that depends on *name* software.

In the previous sample output, the *component-b-pkg* entry does not have an associated name in the Name column. If a software component name is not displayed in the Solaris Product Registry, the component might be damaged.

2. Verify that the software component is damaged.

```

% prodreg info -u name-UUID -i 1 -d
isDamaged=TRUE

```

- u *name-UUID* Displays information on the *name* software component.
- i 1 Displays information on the first instance of the *name* software component.
- d Displays the value of the *isDamaged* attribute of the *name* software component.

The *isDamaged=TRUE* output indicates that the *name* software component is damaged.

3. Identify the packages that form the *name-UUID* software component.

```
% prodreg info -u name-UUID -i 1 -a PKGS
pkgs:
component-a-pkg component-b-pkg
```

4. Verify that these packages are installed on the system.

```
% pkginfo component-a-pkg
application component-a-pkg component-a
```

```
% pkginfo component-b-pkg
ERROR: information on "component-b-pkg" was not found
```

The error message output of the `pkginfo component-b-pkg` command indicates that the `component-b-pkg` package has been removed from the system. The `name` software component might not work without the `component-b-pkg` package.

Example—Identifying Damaged Software Components (prodreg)

The following example shows how to determine if the ExampleSoft software component is damaged.

```
% prodreg browse -m Examplesoft
BROWSE # +/-/. UUID # NAME
=====
1 - root 1 System Registry
2 + a01ee8dd-1dd1-11b2-a3f2-0800209a5b6b 1 Solaris 9 8/03 System Software
3 + 8f64eabf-1dd2-11b2-a3f1-0800209a5b6b 1 Unclassified Software
4 - 95842091-725a-8501-ef29-0472985982be 1 ExampleSoft
233 . 90209809-9785-b89e-c821-0472985982be 1 Example Doc
234 . EXSOztt 1
235 . EXSOblob 1 Example Data
```

The ExampleSoft child component EXSOztt does not have an entry in the NAME column of the Solaris Product Registry. The ExampleSoft software might be damaged. Use the `prodreg info` command with the `-u`, `-i`, and `-d` options to determine if the ExampleSoft software is damaged.

```
% prodreg info -u 95842091-725a-8501-ef29-0472985982be -i 1 -d
isDamaged=TRUE
```

The output of the previous command indicates that the ExampleSoft software is damaged. Use the `-a PKGS` option to the `prodreg info` command to identify the ExampleSoft software packages.

```
% prodreg info
-u 95842091-725a-8501-ef29-0472985982be
-i 1 -a PKGS
```

```
pkgs:
EXSOztt EXSOblob
```

Use the `pkginfo` command to verify that the `EXSOztt` and `EXSOblob` packages are installed on the system.

```
% pkginfo EXSOztt
ERROR: information for "EXSOztt" was not found
```

```
% pkginfo EXSOblob
application EXSOblob          Example Data
```

The output of the `pkginfo` command indicates that the `EXSOztt` package is not installed on the system.

▼ How to Uninstall Software (prodreg)

You can use the `uninstall` subcommand to the `prodreg` command to remove software from your system. When you uninstall software with the `prodreg uninstall` command, you remove a specified software and all the child components associated with that software. Before you remove software, verify that other software does not depend on the software you want to uninstall. See “How to Check Dependencies Between Software Components (prodreg)” on page 298 for instructions on how to check software dependencies.

After you uninstall a software component, you can remove the software and all the child components of that software from the Solaris Product Registry by using the `prodreg unregister -r` command.

1. Become superuser or assume an equivalent role.
2. View the information on the software you want to uninstall.

```
# prodreg browse -u name-UUID
BROWSE # +/-/.  UUID
===== =====
1      -      root
2      +      a01ee8dd-1dd1-11b2-a3f2-0800209a5b6b
3      +      8f64eabf-1dd2-11b2-a3f1-0800209a5b6b
1423   -      name-UUID
1436   .      component-a-UUID
1437   -      component-b-UUID
1462   .      component-c-UUID

# NAME
=====
1 System
Registry
Solaris 9 8/03
System
Software
1 Unclassified
Software
1 name
1 component-a
1 component-b
1 component-c
```

<code>-u name-UUID</code>	Displays information on the software component with the unique identifier <i>name-UUID</i> .
<i>name</i>	Specifies the name of the software component you want to uninstall with the unique identifier <i>name-UUID</i> .
<code>. component-a-UUID</code>	Specifies the unique identifier of the <i>component-a</i> software component that is required by <i>name</i> software.
<i>component-a</i>	Specifies the name of a component that is required by <i>name</i> software.
<code>- component-b-UUID</code>	Specifies the unique identifier of the <i>component-b</i> component that is required by <i>name</i> software. The - symbol indicates that <i>component-b</i> requires an additional software component.
<i>component-b</i>	Specifies the name of a software component that is required by <i>name</i> software.
<code>. component-c-UUID</code>	Specifies the unique identifier of the <i>component-b</i> software component that is required by <i>component-b</i> software.
<i>component-c</i>	Specifies the name of a software component that is required by <i>component-b</i> software.

3. Uninstall the software.

```
# prodreg uninstall -u name-UUID
```

4. Check the dependencies for the software that you want to uninstall.

```
# prodreg info -u name-UUID
Title: name
.
.
.
Child Components:
Name                               UUID                               #
-----
component-a                        component-a-UUID                  1
component-b                        component-b-UUID                  1

Required Components:
Name                               UUID                               #
-----
component-a                        component-a-UUID                  1
```

Check the following information in the output of the `prodreg info` command.

- **Child Components** – Lists the software components that are associated with the *name* software component. When you unregister the *name* software, you also unregister the child components of *name* software. If the output of the previous `prodreg info` command lists any child components, verify that you want to unregister these child components.
- **Required Components** – Lists the software components that are required by the *name* software component. Software components might require other components that are not child components. When you uninstall and unregister a component, only child components are unregistered and uninstalled.
- **Dependent Components** – Lists the components that require *name* software to run. When you unregister the *name* software, you also unregister the dependent components of *name* software. If the output of the previous `prodreg info` command lists any dependent components, verify that you want to unregister these dependent components.

In the previous sample output, *name* software does not have any dependent components.

5. Check the dependencies of *name* software's child components.

```
# prodreg info -u component-a-UUID -i 1 -a "Dependent Components"
Dependent Components:
Name                               UUID                               #
-----
name                               name-UUID                          1

# prodreg info -u component-b-UUID -i 1 -a "Dependent Components"
Dependent Components:
Name                               UUID                               #
-----
name                               name-UUID                          1

# prodreg info -u component-c-UUID -i 1 -a "Dependent Components"
Dependent Components:
Name                               UUID                               #
-----
component-b                         component-b-UUID                     1
```

In the previous sample output, no other software depends on the child components of *name* software.

6. Unregister the software and child components.

```
# prodreg unregister -r -u name-UUID -i 1
-r                               Recursively unregisters software with
                               the unique identifier name-UUID and all
                               the child components of this software.
```

<code>-u name-UUID</code>	Specifies the unique identifier of the software you want to unregister.
<code>-i 1</code>	Specifies the instance of the software you want to unregister.

Example—Uninstalling Software Components (prodreg)

The following example shows how to uninstall ExampleSoft software and all the child components of ExampleSoft software.

```
# prodreg browse -m "ExampleSoft"
BROWSE # +/-/. UUID # NAME
===== =====
1 - root 1 System
Registry
2 + a01ee8dd-1dd1-11b2-a3f2-0800209a5b6b 1 Solaris 9 8/03
System
Software
3 + 8f64eabf-1dd2-11b2-a3f1-0800209a5b6b 1 Unclassified
Software
1423 - 95842091-725a-8501-ef29-0472985982be 1 ExampleSoft
1436 . 90209809-9785-b89e-c821-0472985982be 1 Example Doc
1437 - EXSOztt 1 Example Data
1462 . EXSOblob 1 Example Data

# prodreg uninstall -u 95842091-725a-8501-ef29-0472985982be -i 1

# prodreg info -u 95842091-725a-8501-ef29-0472985982be
Title: ExampleSoft Software
.
.
.
Child Components:
Name UUID #
-----
Example Doc 90209809-9785-b89e-c821-0472985982be 1
Example Data EXSOztt 1

Required Components:
Name UUID #
-----
Example Doc 90209809-9785-b89e-c821-0472985982be 1
Example Data EXSOztt 1

# prodreg info -u 90209809-9785-b89e-c821-0472985982be -i 1
-a "Dependent Components"
Dependent Components:
Name UUID #
-----
ExampleSoft 95842091-725a-8501-ef29-0472985982be 1
```

```

# prodreg info -u EXSOztt -i 1 -a "Dependent Components"
Dependent Components:
Name                               UUID                               #
-----
ExampleSoft                        95842091-725a-8501-ef29-0472985982be 1

# prodreg info -u EXSOblob -i 1 -a "Dependent Components"
Dependent Components:
Name                               UUID                               #
-----
Example Data                        EXSOztt                            1

# prodreg unregister -r -u 95842091-725a-8501-ef29-0472985982be -i 1

```

▼ How to Uninstall Damaged Software (prodreg)

If you try to uninstall a damaged software component by using the `prodreg uninstall` command, the command might fail. This failure can occur if the uninstaller program for the software component has been removed from the system.

Follow these steps to uninstall a software component with no associated uninstaller program on the system.

1. Become superuser or assume an equivalent role.
2. View the information on the software you want to uninstall.

```

# prodreg browse -m "name"
BROWSE # +/-/. UUID                               # NAME
=====
1      -      root                               1 System
Registry
2      +      a01ee8dd-1dd1-11b2-a3f2-0800209a5b6b 1 Solaris 9 8/03
System
Software
3      +      8f64eabf-1dd2-11b2-a3f1-0800209a5b6b 1 Unclassified
Software
4      -      UUID                               1 name
1436   .      component-a-UUID                       1 component-a
1437   .      component-b-UUID                       1

```

`-m "name"`

Displays information on the *name* software component you want to uninstall.

UUID

Specifies the UUID of the software component you want to uninstall.

. component-a-UUID

Specifies the UUID of the *component-a* software component.

<i>component-a</i>	Specifies the name of a child software component of <i>name</i> software.
<i>. component-b-UUID</i>	Specifies the UUID of a child software component of <i>name</i> software.

The *component-b-UUID* entry does not have an associated component name. The missing name value might indicate that this component is damaged.

3. Uninstall the software.

```
# prodreg uninstall -u UUID -i 1
```

The install program requested could not be found

<i>-u UUID</i>	Specifies the UUID of the software component you want to uninstall.
<i>-i 1</i>	Specifies the instance of the software you want to uninstall.

The error message indicates that the uninstaller program is not on the system.

4. Identify the uninstaller program for the software component.

```
# prodreg info -m "name" -a uninstallprogram
```

uninstallprogram: /usr/bin/java -mx64m -classpath
uninstaller-location *uninstall_name*

<i>-m "name"</i>	Displays information on the <i>name</i> software component.
<i>-a uninstallprogram</i>	Displays information on the uninstaller program that is associated with the <i>name</i> software component.
<i>uninstaller-location</i>	Specifies the registered location of the uninstaller program for the <i>name</i> software component.

5. Determine if the uninstaller is in the registered location.

```
# ls uninstaller-location
```

uninstaller-location:
No such file or directory

The output of the `ls` command indicates that the uninstaller program is not in the registered location.

6. Remove the software from the system.

You can remove the software in one of the following ways.

- If you have a system backup available, follow these steps.
 - a. Load the uninstaller program from the backup.

- b. Run the uninstaller program from a shell command-line interface such as a terminal window.
- If you do not have access to the uninstaller program on a backup, follow these steps.
 - a. Unregister the software component.

```
# prodreg unregister -u UUID -i 1
```

- b. Remove any remaining registered components that are required by the software you want to remove.

```
# pkgrm component-a-UUID
```

Example—Uninstalling Damaged Software (prodreg)

The following example shows how to uninstall the damaged ExampleSoft software. In this example, the uninstaller program is not readily available on a system backup.

```
# prodreg browse -m Examplesoft
BROWSE # +/-/.  UUID                                     #  NAME
===== =====
1      -      root                                     1  System
Registry
2      +      a01ee8dd-1dd1-11b2-a3f2-0800209a5b6b  1  Solaris 9 8/03
System
Software
3      +      8f64eabf-1dd2-11b2-a3f1-0800209a5b6b  1  Unclassified
Software
4      -      95842091-725a-8501-ef29-0472985982be  1  ExampleSoft
233    .      90209809-9785-b89e-c821-0472985982be  1  Example Doc
234    .      EXSOzzt                                     1
235    .      EXSOblob                                    1  Example Data

# prodreg uninstall -u 95842091-725a-8501-ef29-0472985982be -i 1
The install program requested could not be found

# prodreg info -m "ExampleSoft" -a uninstallprogram
uninstallprogram: /usr/bin/java -mx64m -classpath
/var/sadm/prod/org.example.ExampleSoft/987573587 uninstall_ExampleSoft

# ls /var/sadm/prod/org.example.ExampleSoft/987573587
/var/sadm/prod/org.example.ExampleSoft/987573587:
No such file or directory

# prodreg unregister -u 95842091-725a-8501-ef29-0472985982be -i 1

# pkgrm EXSOblob
```

▼ How to Reinstall Damaged Software Components (prodreg)

If other software depends on a damaged software component, you might want to reinstall the damaged component, rather than uninstall the component and the other dependent software. You can use the `-f` option with the `prodreg unregister` to perform a forced unregister of the damaged component, and then reinstall the component.

1. **Become superuser or assume an equivalent role.**

2. **View the information on the software you want to reinstall.**

```
# prodreg browse -m "name"
BROWSE # +/-/. UUID # NAME
===== =====
1 - root 1 System Registry
2 + a01ee8dd-1dd1-11b2-a3f2-0800209a5b6b 1 Solaris 9 8/03 System Software
3 + 8f64eabf-1dd2-11b2-a3f1-0800209a5b6b 1 Unclassified Software
4 . UUID 1 name
```

`-m "name"`

Displays information on the *name* software component you want to reinstall.

UUID

Specifies the UUID of the software component you want to reinstall.

3. **Identify the software that depends on the software you want to reinstall.**

```
# prodreg info -m "name" -a "Dependent Components"
Dependent Components:
Name UUID #
-----
component-a component-a-UUID 1
```

`-m "name"`

Specifies the name of the software component you want to reinstall.

`-a "Dependent Components"`

Displays the components that depend on *name* software.

component-a

Specifies the name of a software component that depends on *name* software.

component-a-UUID

Specifies the UUID of the *component-a* software component.

The *component-a* software component depends on the software you want to reinstall. To reinstall *name* software and not unregister *component-a*, you must perform a forced unregister of *name* software, then reinstall *name* software.

4. Unregister only the software component you want to reinstall.

```
# prodreg unregister -f -u UUID
```

5. Reinstall the software component.

```
# /usr/bin/java -cp /usr/installers/installer
```

installer

Specifies the name of the installer program for *name* software.

Example—Reinstalling Damaged Software Components (prodreg)

The following example shows how to reinstall the damaged software component `ComponentSoft` without unregistering or uninstalling the dependent component `ExampleSoft`.

```
# prodreg browse -m "ComponentSoft"
BROWSE # +/-/.  UUID                                     #  NAME
===== =====
1      -      root                                     1  System
                                           Registry
2      +      a01ee8dd-1dd1-11b2-a3f2-0800209a5b6b  1  Solaris 9 8/03
                                           System
                                           Software
3      +      8f64eabf-1dd2-11b2-a3f1-0800209a5b6b  1  Unclassified
                                           Software
4      .      86758449-554a-6531-fe90-4352678362fe  1  ComponentSoft

# prodreg info -m "ComponentSoft" -a "Dependent Components"
Dependent Components:
Name                                     UUID                                     #
-----
ExampleSoft                             95842091-725a-8501-ef29-0472985982be  1

# prodreg unregister -f -u 86758449-554a-6531-fe90-4352678362fe -i 1

# /usr/bin/java -cp /usr/installers/org.example.componentsoft
```

Adding and Removing Signed Packages (Task Map)

The following task map describes the tasks for adding and removing signed packages.

Task	Description	For Instructions
Import a certificate	Import a trusted certificate with the <code>pkgadm addcert</code> command.	“How to Import a Trusted Certificate into the Package Keystore (<code>pkgadm addcert</code>)” on page 311
(Optional) Display the details of one or more certificates	Display the details of a certificate with the <code>pkgadm listcert</code> command.	“How to Display Certificate Information (<code>pkgadm listcert</code>)” on page 313
(Optional) Remove a certificate	Remove a certificate with the <code>pkgadm removecert</code> command.	“How to Remove a Certificate (<code>pkgadm removecert</code>)” on page 314
(Optional) Set up a proxy server	Specify a proxy server if your system is behind a firewall with a proxy.	“How to Set Up a Proxy Server” on page 314
Add a signed package	After the root certificate is imported, you can add a signed package with the <code>pkgadd</code> command.	“How to Add a Signed Package (<code>pkgadd</code>)” on page 315
(Optional) Remove a signed package	Removing a signed package is identical to removing an unsigned package.	“How to Remove Software Packages (<code>pkgrm</code>)” on page 324

▼ How to Import a Trusted Certificate into the Package Keystore (`pkgadm addcert`)

1. Become superuser or assume an equivalent role.
2. Verify that the Root CA certificate exists in the Java keystore.

```
# keytool -storepass storepass -list -keystore certfile
```

<code>keytool</code>	Manages a Java keystore (database) of private keys and their associated X.509 certificate chains that authenticate the corresponding public keys. Also manages certificates from trusted entities. For more information on the <code>keytool</code> command, see <code>keytool-Key and Certificate Management Tool</code> .
<code>-storepass storepass</code>	Specifies the password that protects the integrity of the Java keystore.
<code>-list</code>	By default, prints the MD5 fingerprint of a certificate.
<code>-keystore certfile</code>	Specifies the name and location of the persistent Java keystore file.

3. Export the Root CA certificate from the Java keystore to a temporary file.

```
# keytool -export -storepass storepass -alias gtecybertrustca -keystore
gtecybertrustca -keystore /usr/j2se/jre/lib/security/cacerts -file filename
```

<code>-export</code>	Exports the trusted certificate.
<code>-storepass storepass</code>	Specifies the password that protects the integrity of the Java keystore.
<code>-alias gtecybertrustca</code>	Identifies the alias of the trusted certificate.
<code>-keystore certfile</code>	Specifies the name and location of the keystore file.
<code>-file filename</code>	Identifies the file to hold the exported certificate.

4. Import a trusted certificate to the package keystore.

```
# pkgadm addcert -t -f format certfile
```

<code>-t</code>	Indicates that the certificate is a trusted CA certificate. The command output includes the details of the certificate, which the user is asked to verify.
<code>-f format</code>	Specifies the format of the certificates or private key. When importing a certificate, it must be encoded using either the PEM (<code>pem</code>) or binary DER (<code>der</code>) format.
<code>certfile</code>	Specifies the file that contains the certificate.

For more information, see the `pkgadm` man page.

5. Remove the temporary file.

Example—Importing a Trusted Certificate

The following example shows how to import a trusted certificate. In this example, Sun's Root CA certificate is imported from the Java keystore into the package keystore with the `keytool` command.

```
# keytool -export -storepass changeit -alias gtecybertrustca -keystore
gtecybertrustca -keystore /usr/j2se/jre/lib/security/cacerts -file
/tmp/root.crt
Certificate stored in file </tmp/root.crt>
# pkgadm addcert -t -f der /tmp/root.crt
Enter Keystore Password: storepass
    Keystore Alias: GTE CyberTrust Root
    Common Name: GTE CyberTrust Root
    Certificate Type: Trusted Certificate
    Issuer Common Name: GTE CyberTrust Root
    Validity Dates:<Feb 23 23:01:00 1996 GMT>-<Feb 23 23:59:00 2006 GMT>
    MD5 Fingerprint: C4:D7:F0:B2:A3:C5:7D:61:67:F0:04:CD:43:D3:BA:58
    SHA1 Fingerprint: 90:DE:DE:9E:4C:4E:9F:6F:D8:86:17:57:9D:D3:91:BC...
Trusting certificate <GTE CyberTrust Root>
Type a Keystore protection Password.
Press ENTER for no protection password (not recommended): xxx
For Verification: Type a Keystore protection Password.
Press ENTER for no protection password (not recommended): xxx
Certificate(s) from </tmp/root.crt> are now trusted
# rm /tmp/root.crt
```

▼ How to Display Certificate Information (`pkgadm listcert`)

1. Become superuser or assume an equivalent role.
2. Display the contents of the package keystore.

```
# pkgadm listcert
```

Example—Displaying Certificate Information (`pkgadm listcert`)

The following example shows how to display the details of a locally stored certificate.

```
# pkgadm listcert -P pass:storepass
    Keystore Alias: GTE CyberTrust Root
    Common Name: GTE CyberTrust Root
    Certificate Type: Trusted Certificate
    Issuer Common Name: GTE CyberTrust Root
    Validity Dates: <Feb 23 23:01:00 1996 GMT> - <Feb 23 23:59:00 2006 GMT>
    MD5 Fingerprint: C4:D7:F0:B2:A3:C5:7D:61:67:F0:04:CD:43:D3:BA:58
    SHA1 Fingerprint: 90:DE:DE:9E:4C:4E:9F:6F:D8:86:17:57:9D:D3:91:BC...
```

▼ How to Remove a Certificate (pkgadm removcert)

1. Become superuser or assume an equivalent role.
2. Remove the trusted certificate from the package keystore.

```
# pkgadm removcert -n "certfile"
```

The `-n "certfile"` option specifies the alias of the user certificate/key pair or the alias of the trusted certificate.

Note – View the alias names for certificates with the `pkgadm listcert` command.

Example—Removing a Certificate (pkgadm removcert)

The following example shows how to remove a certificate.

```
# pkgadm listcert
Enter Keystore Password: storepass
  Keystore Alias: GTE CyberTrust Root
    Common Name: GTE CyberTrust Root
  Certificate Type: Trusted Certificate
  Issuer Common Name: GTE CyberTrust Root
    Validity Dates:<Feb 23 23:01:00 1996 GMT>-<Feb 23 23:59:00 2006 GMT>
    MD5 Fingerprint: C4:D7:F0:B2:A3:C5:7D:61:67:F0:04:CD:43:D3:BA:58
    SHA1 Fingerprint: 90:DE:DE:9E:4C:4E:9F:6F:D8:86:17:57:9D:D3:91:BC...
# pkgadm removcert -n "GTE CyberTrust Root"
Enter Keystore Password: storepass
Successfully removed Certificate(s) with alias <GTE CyberTrust Root>
```

▼ How to Set Up a Proxy Server

If your system is behind a firewall with a proxy, you will need to set up a proxy server before you can add a package from an HTTP server.

1. Become superuser or assume an equivalent role.
2. Select one of the following methods to specify a proxy server.
 - a. Specify the proxy server by using the `http_proxy`, `HTTPPROXY`, or `HTTPPROXYPORT` environment variable.

For example:

```
# setenv http_proxy http://mycache.domain:8080
```

Or, specify one of the following:

```
# setenv HTTPPROXY mycache.domain
# setenv HTTPPROXYPORT 8080
```

b. Specify the proxy server on the `pkgadd -x` command line.

For example:

```
# pkgadd -x mycache.domain:8080 -d http://myserver.com/pkg SUNWpkg
```

c. Create an admin file that includes proxy server information.

For example:

```
# cat /tmp/admin
mail=
instance=unique
partial=ask
runlevel=ask
idepend=ask
rdepend=ask
space=ask
setuid=ask
conflict=ask
action=ask
networktimeout=60
networkretries=3
authentication=quit
keystore=/var/sadm/security
basedir=default
proxy=mycache.domain:8080
```

Then, identify the admin file with the `pkgadd -a` command. For example:

```
# pkgadd -a /tmp/admin -d http://myserver.com/pkg SUNWpkg
```

▼ How to Add a Signed Package (`pkgadd`)

This procedure assumes that you have imported Sun's Root CA certificate. For more information, see "How to Import a Trusted Certificate into the Package Keystore (`pkgadm addcert`)" on page 311.

For information about setting up a proxy server, see "How to Set Up a Proxy Server" on page 314.

- 1. Become superuser or assume an equivalent role.**
- 2. Add a signed package.**

```
# pkgadd -d /pathname/package-name
```

The `-d device-name` option specifies the device from which the package is installed. The device can be a directory, tape, diskette, or removable disk. The device can also be a data stream created by the `pkgtrans` command.

Examples—Adding a Signed Package (pkgadd)

The following example shows how to add a signed package that has already been downloaded.

```
# # pkgadd -d /tmp/signed_pppd
The following packages are available:
  1  SUNWpppd      Solaris PPP Device Drivers
                        (sparc) 11.10.0,REV=2003.05.08.12.24

Select package(s) you wish to process (or 'all' to process
all packages). (default: all) [?,??,q]: all
Enter keystore password:
## Verifying signature for signer <User Cert 0>
.
.
.
```

The following example shows how to install a signed package using an HTTP URL as the device name. The URL must point to a stream-formatted package.

```
# pkgadd -d http://install/signed-video.pkg

## Downloading...
.....25%.....50%.....75%.....100%
## Download Complete
.
.
```

Managing Software Packages With Package Commands (Task Map)

The following task map describes the software management tasks that you can do with the package commands for both signed and unsigned packages.

Task	Description	For Instructions
Add a software packages to the local system	You can add software packages to the local system with the <code>pkgadd</code> command.	“How to Add Software Packages (<code>pkgadd</code>)” on page 317
Add software packages to a spool directory	You can add software packages to a spool directory without actually installing the software.	“Adding a Software Package to a Spool Directory” on page 320

Task	Description	For Instructions
List information about all installed software packages	You can list information about installed packages with the <code>pkginfo</code> command.	“How to List Information About All Installed Packages (<code>pkginfo</code>)” on page 321
Check the integrity of installed software packages	You can verify the integrity of installed software packages with the <code>pkgchk</code> command.	“How to Check the Integrity of Installed Software Packages (<code>pkgchk</code>)” on page 322
Remove software packages	You can remove unneeded software packages with the <code>pkgrm</code> command.	“How to Remove Software Packages (<code>pkgrm</code>)” on page 324

▼ How to Add Software Packages (`pkgadd`)

1. **Become superuser or assume an equivalent role.**
2. **Remove any already installed packages with the same names as the ones you are adding.**

This step ensures that the system keeps a proper record of software that has been added and removed. There might be times when you want to maintain multiple versions of the same application on the system. For strategies on maintaining multiple software copies, see “Guidelines for Removing Packages (`pkgrm`)” on page 282, and for task information, see “How to Remove Software Packages (`pkgrm`)” on page 324.

3. **Add a software package to the system.**

```
# pkgadd -a admin-file -d device-name pkgid ...
```

`-a admin-file` (Optional) Specifies an administration file that the `pkgadd` command should consult during the installation. For details about using an administration file, see “Using an Administration File” on page 283 in the previous chapter.

`-d device-name` Specifies the absolute path to the software packages. `device-name` can be the path to a device, a directory, or a spool directory. If you do not specify the path where the package resides, the `pkgadd` command checks the default spool directory (`/var/spool/pkg`). If the package is not there, the package installation fails.

`pkgid` (Optional) Is the name of one or more packages, separated by spaces, to be installed. If omitted, the `pkgadd` command installs all available packages.

If the `pkgadd` command encounters a problem during installation of the package, it displays a message related to the problem, followed by this prompt:

Do you want to continue with this installation?

Respond with *yes*, *no*, or *quit*. If more than one package has been specified, type *no* to stop the installation of the package being installed. The `pkgadd` command continues to install the other packages. Type *quit* to stop the installation.

4. Verify that the package has been installed successfully.

```
# pkgchk -v pkgid
```

If no errors occur, a list of installed files is returned. Otherwise, the `pkgchk` command reports the error.

Example—Adding Software Packages From a Mounted CD

The following example shows how to install the `SUNWp15u` package from a mounted Solaris 9 CD. The example also shows how to verify that the package files were installed properly.

```
# pkgadd -d /cdrom/cdrom0/s0/Solaris_9/Product SUNWp15u
.
.
.
Installation of <SUNWp15u> was successful.
# pkgchk -v SUNWp15u
/usr
/usr/bin
/usr/bin/perl
/usr/perl5
/usr/perl5/5.00503
.
.
.
```

Example—Installing Software Packages From a Remote Package Server

If the packages you want to install are available from a remote system, you can manually mount the directory that contains the packages (in package format) and install packages on the local system.

The following example shows how to install software packages from a remote system. In this example, assume that the remote system named `package-server` has software packages in the `/latest-packages` directory. The `mount` command mounts the packages locally on `/mnt`, and the `pkgadd` command installs the `SUNWp15u` package.

```
# mount -F nfs -o ro package-server:/latest-packages /mnt
# pkgadd -d /mnt SUNWp15u
.
```

```
.  
.  
Installation of <SUNWpl5u> was successful.
```

If the automounter is running at your site, you do not need to mount the remote package server manually. Instead, use the automounter path, in this case, `/net/package-server/latest-packages`, as the argument to the `-d` option.

```
# pkgadd -d /net/package-server/latest-packages SUNWpl5u
```

```
.  
.  
.  
Installation of <SUNWpl5u> was successful.
```

The following example is similar to the previous example, except that it uses the `-a` option and specifies an administration file named `noask-pkgadd`, which is illustrated in “Avoiding User Interaction When Adding Packages (`pkgadd`)” on page 283. In this example, assume that the `noask-pkgadd` administration file is in the default location, `/var/sadm/install/admin`.

```
# pkgadd -a noask-pkgadd -d /net/package-server/latest-packages SUNWpl5u
```

```
.  
.  
.  
Installation of <SUNWpl5u> was successful.
```

Example —Installing Software Packages From an HTTP URL

The following example shows how to install a package using an HTTP URL as the device name. The URL must point to a stream-formatted package.

```
# pkgadd -d http://install/xf86-4.3.0-video.pkg
```

```
## Downloading...  
.....25%.....50%.....75%.....100%  
## Download Complete
```

The following packages are available:

- | | | |
|---|-----------|-----------------------------------|
| 1 | SUNWxf86r | XFree86 Driver Porting Kit (Root) |
| | | (i386) 4.3.0,REV=0.2003.02.28 |
| 2 | SUNWxf86u | XFree86 Driver Porting Kit (User) |
| | | (i386) 4.3.0,REV=0.2003.02.28 |

```
.  
.  
.
```

Adding a Software Package to a Spool Directory

For convenience, you can copy frequently installed packages to a spool directory. If you copy packages to the default spool directory, `/var/spool/pkg`, you do not need to specify the source location of the package (`-d device-name` argument) when you use the `pkgadd` command. The `pkgadd` command, by default, checks the `/var/spool/pkg` directory for any packages specified on the command line. Note that copying packages to a spool directory is not the same as installing the packages on a system.

▼ How to Add Software Packages to a Spool Directory (pkgadd)

1. **Become superuser or assume an equivalent role.**
2. **Remove any already spooled packages with the same names as the packages you are adding.**

For information on removing spooled packages, see “Example—Removing a Spooled Software Package” on page 325.

3. **Add a software package to a spool directory.**

```
# pkgadd -d device-name -s spooldir pkgid ...
```

<code>-d device-name</code>	Specifies the absolute path to the software packages. <i>device-name</i> can be the path to a device, a directory, or a spool directory.
<code>-s spooldir</code>	Specifies the name of the spool directory where the package will be spooled. You must specify a <i>spooldir</i> .
<i>pkgid</i>	(Optional) Is the name of one or more packages, separated by spaces, to be added to the spool directory. If omitted, the <code>pkgadd</code> command copies all available packages.

4. **Verify that the package has been copied successfully to the spool directory.**

```
$ pkginfo -d spooldir | grep pkgid
```

If *pkgid* is copied correctly, the `pkginfo` command returns a line of information about the *pkgid*. Otherwise, the `pkginfo` command returns the system prompt.

Example—Setting Up a Spool Directory From a Mounted CD

The following example shows how to transfer the `SUNWman` package from a mounted SPARC Solaris 9 CD to the default spool directory (`/var/spool/pkg`).

```
# pkgadd -d /cdrom/cdrom0/s0/Solaris_9/Product -s /var/spool/pkg SUNWman
Transferring <SUNWman> package instance
```

Example—Setting Up a Spool Directory From a Remote Software Package Server

If packages you want to copy are available from a remote system, you can manually mount the directory that contains the packages, in package format, and copy them to a local spool directory.

The following example shows the commands to do this scenario. In this example, assume that the remote system named `package-server` has software packages in the `/latest-packages` directory. The `mount` command mounts the package directory locally on `/mnt`, and the `pkgadd` command copies the `SUNWp15p` package from `/mnt` to the default spool directory (`/var/spool/pkg`).

```
# mount -F nfs -o ro package-server:/latest-packages /mnt
# pkgadd -d /mnt -s /var/spool/pkg SUNWp15p
Transferring <SUNWp15p> package instance
```

If the automounter is running at your site, you do not have to mount the remote package server manually. Instead, use the automounter path, in this case, `/net/package-server/latest-packages`, as the argument to the `-d` option.

```
# pkgadd -d /net/package-server/latest-packages -s /var/spool/pkg SUNWp15p
Transferring <SUNWp15p> package instance
```

Example—Installing Software Packages From the Default Spool Directory

The following example shows how to install the `SUNWp15p` package from the default spool directory. When no options are used, the `pkgadd` command searches the `/var/spool/pkg` directory for the named packages.

```
# pkgadd SUNWp15p
.
.
.
Installation of <SUNWp15p> was successful.
```

How to List Information About All Installed Packages (`pkginfo`)

List information about installed packages with the `pkginfo` command.

```
$ pkginfo
```

Example—Listing All Packages Installed

The following example shows the `pkginfo` command to list all packages installed on a local system, whether that system is a standalone or server. The output shows the primary category, package name, and the description of the package.

```
$ pkginfo
system      SUNWaccr      System Accounting, (Root)
system      SUNWaccu      System Accounting, (Usr)
system      SUNWadmap     System administration applications
system      SUNWadmc      System administration core libraries
.
.
.
```

Example—Displaying Detailed Information About Software Packages

```
$ pkginfo -l SUNWcar
PKGINST:  SUNWcar
NAME:     Core Architecture, (Root)
CATEGORY: system
ARCH:     sparc.sun4u
VERSION:  11.9.0,REV=2002.04.06.15.27
BASEDIR:  /
VENDOR:   Sun Microsystems, Inc.
DESC:     core software for a specific hardware platform group
PSTAMP:   crash20020406153633
INSDATE:  Nov 19 2002 14:49
HOTLINE:  Please contact your local service provider
STATUS:   completely installed
FILES:    111 installed pathnames
          36 shared pathnames
          40 directories
          56 executables
          18843 blocks used (approx)
```

▼ How to Check the Integrity of Installed Software Packages (`pkgchk`)

1. Become superuser or assume an equivalent role.
2. Check the status of an installed package.

```
# pkgchk -a| -c -v pkgid ...
# pkgchk -d spooldir pkgid ...
```

<code>-a</code>	Specifies to audit only the file attributes, that is, the permissions, rather than the file attributes and contents, which is the default.
<code>-c</code>	Specifies to audit only the file contents, rather than the file contents and attributes, which is the default.
<code>-v</code>	Specifies verbose mode, which displays file names as they are processed.
<code>-d <i>spooldir</i></code>	Specifies the absolute path of the spool directory.
<code><i>pkgid</i></code>	(Optional) Is the name of one or more packages, separated by spaces. If you do not specify a <i>pkgid</i> , all the software packages installed on the system are checked.

Example—Checking the Contents of Installed Software Packages

The following example shows how to check the contents of a package.

```
# pkgchk -c SUNWbash
```

If no errors occur, the system prompt is returned. Otherwise, the `pkgchk` command reports the error.

Example—Checking the File Attributes of Installed Software Packages

The following example shows how to check the file attributes of a package.

```
# pkgchk -a SUNWbash
```

If no errors occur, the system prompt is returned. Otherwise, the `pkgchk` command reports the error.

Example—Checking Software Packages Installed in a Spool Directory

The following example shows how to check a software package that was copied to a spool directory (`/export/install/packages`).

```
# pkgchk -d /export/install/packages
## checking spooled package <SUNWadmap>
## checking spooled package <SUNWadmfw>
## checking spooled package <SUNWadmc>
## checking spooled package <SUNWsadml>
```

Note – The checks made on a spooled package are limited because not all information can be audited until a package is installed.

Removing Software Packages

Use the associated tool that you used to add or install a software package to remove or uninstall a software package. For example, if you used the Web Start installer to install software, use the Web Start uninstaller to uninstall software.



Caution – Do not use the `rm` command to remove software packages.

▼ How to Remove Software Packages (`pkgrm`)

1. **Become superuser or assume an equivalent role.**
2. **Remove an installed package.**

```
# pkgrm pkgid ...
```

pkgid identifies the name of one or more packages, separated by spaces, to be removed. If omitted, `pkgrm` removes all available packages.

Example—Removing Software Packages

This example shows how to remove a package.

```
# pkgrm SUNWctu
```

```
The following package is currently installed:
```

```
SUNWctu          Netra ct usr/platform links (64-bit)
                  (sparc.sun4u) 11.9.0,REV=2001.07.24.15.53
```

```
Do you want to remove this package? y
```

```
## Removing installed package instance <SUNWctu>
## Verifying package dependencies.
## Processing package information.
## Removing pathnames in class <none>
```

```
.
.
.
```

Example—Removing a Spooled Software Package

This example shows how to remove a spooled package.

```
# pkgrm -s /export/pkg SUNWdmfex.u
The following package is currently spooled:
  SUNWdmfex.u          Sun Davicom 10/100Mb Ethernet Driver (64-bit)
                      (sparc.sun4u) 11.9.0,REV=2001.07.24.15.53

Do you want to remove this package? y
Removing spooled package instance <SUNWdmfex.u>
```

Adding and Removing Software Packages With Admintool (Task Map)

The following task map describes the software management tasks that you can do with Admintool.

Task	Description	For Instructions
Add software packages with Admintool	You can view or add software packages.	“How to Add Software Packages With Admintool” on page 325
Remove software packages with Admintool	You can view or remove software packages.	“How to Remove Software Packages With Admintool” on page 327

The Solaris operating environment includes Admintool, which is a graphical user interface for performing several administration tasks, including adding and removing software packages. Specifically, you can use Admintool to do the following:

- Add software packages to a local system
- Remove software packages from a local system
- View software already installed on the local system
- Customize software packages to be installed
- Specify an alternate installation directory for a software package

▼ How to Add Software Packages With Admintool

1. Become superuser.

Unless you are a member of the `sysadmin` group (group 14), you must become superuser or assume an equivalent role to add or remove software packages with

Admintool.

2. Load a Solaris 9 Software CD or DVD into the drive.

Volume Manager automatically mounts the CD.

3. Start Admintool.

```
# admintool &
```

The Users window is displayed.

4. Choose Software from the Browse menu.

The Software window is displayed.

5. Choose Add from the Edit menu.

The Set Source Media window might appear. If so, specify the path to the installation media and click OK. The default path is a mounted Solaris CD.

The Add Software window is displayed.

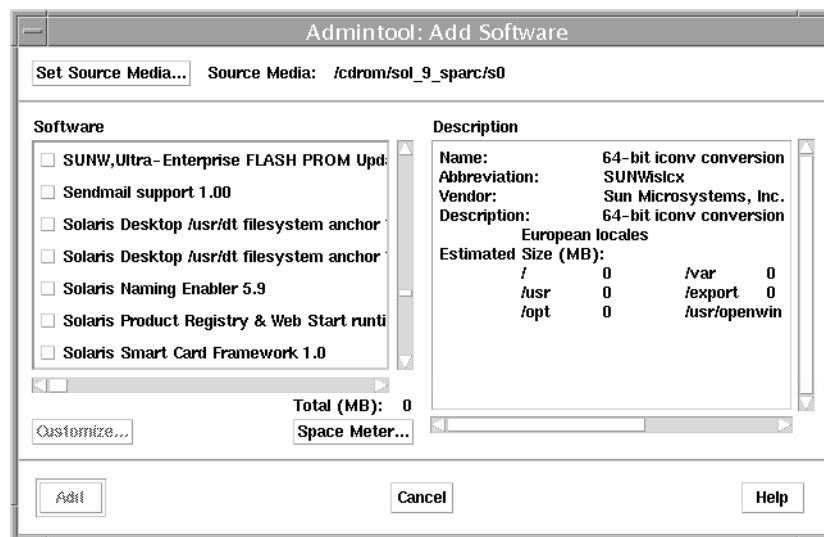

6. Select the software you want to install on the local system.

In the Software portion of the window, click the check boxes that correspond to the software you want to install.

7. Click Add.

A Command Tool window appears for each package being installed, displaying the installation output.

The Software window is refreshed to display the packages just added.

▼ How to Remove Software Packages With Admintool

1. Become superuser.

Unless you are a member of the `sysadmin` group (group 14), you must become superuser or assume an equivalent role to add or remove software packages with Admintool.

2. Start Admintool.

```
# admintool &
```

The Users window is displayed.

3. Choose Software from the Browse menu.

The Software window is displayed.

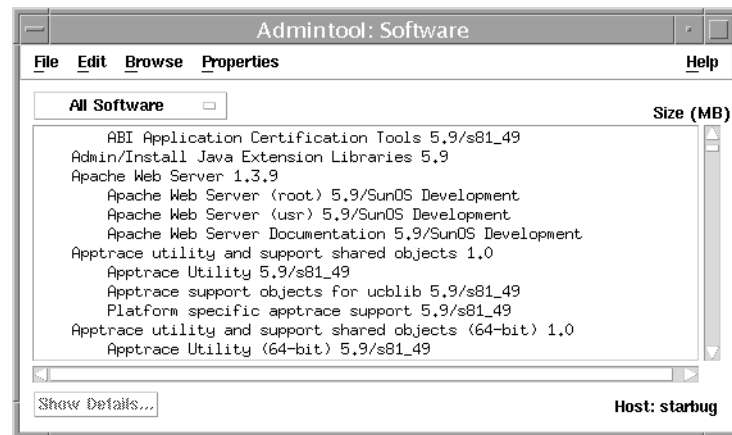

4. Select the software you want to delete from the local system.

5. Choose Delete from the Edit menu.

A warning pop-up window is displayed to confirm whether you really want to delete the software.

6. Click Delete to confirm that you want to delete the software.

For each package that is being deleted, a Command Tool window is displayed that asks for confirmation, again, before deleting the software. Type `y`, `n`, or `q`. If you choose to delete the software, the output from the removal process is displayed.

Managing Solaris Patches (Overview)

Patch management involves listing or adding Solaris patches from a system running the Solaris release. Patch management might also involve removing unwanted or faulty patches. Removing patches is also called *backing out* patches.

This is a list of the overview information in this chapter.

- “What Is a Patch?” on page 329
- “What Is a Signed Patch?” on page 330
- “Accessing Solaris Patches” on page 330
- “Tools for Managing Solaris Patches” on page 332

For step-by-step instructions on adding a patch to your system, see “Managing Patches in the Solaris Environment (Road Map)” on page 337.

For information on adding patches to diskless client systems, see “Patching Diskless Client OS Services” on page 138.

What Is a Patch?

A patch is a collection of files and directories that replace or update existing files and directories that are preventing proper execution of the existing software. The existing software is derived from a specified *package* format, which conforms to the Application Binary Interface. For details about packages, see Chapter 22.

What Is a Signed Patch?

A *signed* patch is a patch with a digital signature. A patch with a valid digital signature ensures that the patch has not been modified after the signature was applied to the patch. Using signed patches is a more secure method of downloading or adding patches because the patches include a digital signature that can be verified before the patch is added to your system.

Patches that are available for the Solaris 2.6, 7, 8, and 9 releases include a digital signature. Patches without a digital signature, or *unsigned patches*, are also available, but eventually, all patches will be *signed patches*. A valid digital signature ensures that the patch has not been modified since the signature was applied.

Signed patches are stored in Java archive format (JAR) files and are available from the SunSolve OnlineSM web site.

In previous Solaris releases, you could use the `smpatch` command with PatchPro to add signed patches to your system. For step-by-step instructions on using the `smpatch` command, see “Preparation for Managing Signed Patches with `smpatch` Command (Task Map)” on page 343

In this Solaris release, you can use the `patchadd` command to add signed patches to your system. For step-by-step instructions on using the `patchadd` command, see “Adding Signed Patches With `patchadd` Command (Task Map)” on page 339.

For overview information about signed patches, see “Signed Packages and Patches” on page 275.

Accessing Solaris Patches

All Sun customers can access patches through the SunSolve OnlineSM web site. The following table describes the various ways to access Solaris patches.

TABLE 24-1 Ways to Access Solaris Patches

Customer Type	Description
SunSpectrum contract customer	You have access to the SunSolve database of patches and patch information. They are available from the SunSolve Online web site or by using anonymous <code>ftp</code> . These patches are updated nightly.

TABLE 24-1 Ways to Access Solaris Patches (Continued)

Customer Type	Description
Not a SunSpectrum contract customer	You have access to a general set of security patches and other recommended patches. These patches are available through SunSolve Online.

You can access Solaris patches from a web site or by using anonymous ftp.

To access patches from a web site, you need a system that is:

- Connected to the Internet
- Capable of running a web browser such as the Netscape™ software.

To access patches by anonymous ftp, you need a system that is:

- Connected to the Internet
- Capable of running the ftp program

Access patches from the SunSolve OnlineSM web site by using the following URL:

`http://sunsolve.Sun.COM/pub-cgi/show.pl?target=patches/patch-access`

You can install either a patch cluster of recommended patches or individual patches that are freely available. Patch reports are also available.

Solaris Patch Numbering

Patches are identified by unique alphanumeric strings, with the patch base code first, a hyphen, and a number that represents the patch revision number. For example, patch 108528-10 is a *patch ID* for the SunOS 5.8 kernel update patch.

Tools for Managing Solaris Patches

The following table summarizes Solaris patch management features.

Feature	<code>patchadd/patchrm</code> Commands	Solaris 2.6, 7, and 8 Patch Management Tools	Solaris 9 Patch Management Tools	PatchPro Interactive or PatchPro Expert
How do I get this tool?	Bundled in Solaris release (SUNWswmt)	Must download tool from http://www.sun.com/PatchPro	Must download tool from http://www.sun.com/PatchPro	Run tool from http://www.sun.com/PatchPro
Solaris release availability	Solaris 2.6, 7, 8, and 9 releases	Solaris 2.6, 7, and 8	Solaris 9	Solaris 2.6, 7, 8, and 9
Adds signed patches?	Yes, and automatically verifies the signed patch when it is downloaded	Yes, and automatically verifies the signed patch when it is downloaded	Yes, and automatically verifies the signed patch when it is downloaded	No
Adds unsigned patches?	Yes	No	Yes	Yes
GUI available?	No	No	Yes	No
Analyzes system for required patches and downloads signed or unsigned patches	No	Yes, both signed and unsigned patches	Yes, both signed and unsigned patches	Yes, unsigned patches only
Local and remote system patch support	Local	Local	Local and Remote	No
RBAC support?	Yes	No	Yes	No

Detailed information about how to install and back out a patch is provided in the `patchadd(1M)` and `patchrm(1M)` man pages. Each patch also contains a `README` file that contains information about the patch.

Solaris Patch Management Tools

In previous Solaris releases, you could use the `smpatch` command to add signed patches to your system.

Solaris Patch Manager Base Version 1.0, which is the `smpatch` command, is used to manage signed patches on systems running the Solaris 2.6, 7, and 8 releases. You can use the `smpatch` command with PatchPro 2.1 to manage signed patches on systems running the Solaris 9 release.

Both signed patch tools provide the following capabilities:

- They analyze patch requirements and download signed patches on the local system only. Similar to PatchPro Expert, this tool reads the `/etc/patchpro_hdw.conf` file to determine what hardware is installed. Other than this feature, the two tools are entirely independent.
- They apply one or more signed patches in JAR format, which also authenticates the patch or patches to be added.
- They remove one or more patches, which checks patch dependencies before removing the patch or patches.
- You can set up a default patch policy that allows the installation of various patch types such as `clientroot`, `clientusr`, `rebootafter`, or `standard` patches.
- If you upgrade to the Solaris 9 release, the `smpatch` command is automatically upgraded to the latest version.

The `patchadd` command is available to add unsigned patches to systems running the Solaris 2.6, 7, 8, and 9 releases. You cannot use Patch Manager Base Version 1.0 to add unsigned patches on these systems.

Restrictions When Using Solaris 2.6, 7, or 8 Signed Patch Tools

The Solaris 2.6, 7, and 8 signed patch tools limitations are:

- You cannot install signed patches to alternate boot environments nor to diskless clients.
- You cannot install patches that do not have a digital signature.
- You cannot install patches with the `rebootimmediate`, `reconfigimmediate`, or `nonconforming` attributes.

Package Requirements for Solaris Patch Management Tools (`smpatch`)

When you install the patch management tools, which is the `smpatch` command, several Solaris packages are added to your system, including some Java packages, that are required for the tools to run. In addition, several packages must be installed on your system before you can install the patch tools. These packages are as follows:

- **Solaris 2.6 release** – Core cluster plus the `SUNWmfrun`, `SUNWlibC`, and `SUNWxcu4` packages.

- **Solaris 7 and 8 releases** – Core cluster plus the SUNWmfrun and SUNWlibc packages.
- **Solaris 9 release** – Developer cluster (SUNWprog) is required if you are using the Solaris Management Console Patches Tool with PatchPro 2.1.

For information on verifying whether the required Solaris packages are installed on your system, see “How to Verify Package Requirements for Signed Patch Tools (smpatch)” on page 345.

Downloading the Solaris Patch Management Tools (smpatch)

You can download the Solaris patch management tools from the following location:

<https://www.sun.com/PatchPro>

Follow the links for your Solaris release and select the appropriate tar file.

Selecting the Best Method for Adding Signed Patches

After you have installed a patch management tool, you can use several different methods of downloading or adding a signed patch or patches to your system. Use the following table to determine which method is best for your needs.

Command or Tool	Description	For More Information
patchadd	Solaris 9 12/03 release only – Use this command to add signed patches to your system after you have set up your package keystore.	patchadd(1m)
smpatch update	Use this command to identify required patches, and then, automatically download and add the patches to your system.	smpatch(1M)
smpatch analyze	Use this command to identify required patches and display a list of required patch IDs for your system. Then, you could use the smpatch download and smpatch add commands to download and add the patches to your system.	smpatch(1M)
smpatch download and smpatch add	Use these commands to download and add a patch or patches to your system. These commands also download and add any prerequisite patches.	“Examples—Downloading and Adding a Signed Patch (smpatch)” on page 351

Command or Tool	Description	For More Information
ftp and smpatch add	Use the ftp command to transfer a patch or patches to your system. Then, use the smpatch add command to add the patch or patches to your system.	“Examples—Downloading and Adding a Signed Patch (smpatch)” on page 351
Solaris Management Console Patches Tool	For Solaris 9 systems only – Use this tool when you want the convenience of a GUI tool to manage signed patches.	Solaris Management Console online help

Managing Solaris Patches (Tasks)

This chapter provides step-by-step instructions for managing patches in the Solaris environment.

This is a list of the task maps in this chapter.

- “Managing Patches in the Solaris Environment (Road Map)” on page 337
- “Adding Signed Patches With `patchadd` Command (Task Map)” on page 339
- “Preparation for Managing Signed Patches with `smpatch` Command (Task Map)” on page 343
- “Managing Signed Patches With `smpatch` Command (Task Map)” on page 350
- “Managing Unsigned Solaris Patches (Task Map)” on page 356

For overview information about managing patches in the Solaris environment, see Chapter 24.

For information on troubleshooting problems with the `smpatch` command, see <http://sunsolve.Sun.COM/pub-cgi/show.pl?target=patches/spfaq>.

Managing Patches in the Solaris Environment (Road Map)

Use this map to identify all the tasks for managing patches in the Solaris environment. Each task points to a series of additional tasks such as managing signed or unsigned patches.

Task	Description	For Instructions
Identify disk space requirements for patches	Identify whether your system has enough disk space to download or spool patches.	"Identifying Disk Space Requirements for Patches" on page 338
Determine if adding signed or unsigned patches	Determine whether adding signed or unsigned patches is best for your environment.	"Selecting Signed or Unsigned Patches for Your Environment" on page 339
Add a signed or unsigned patch to your system	You can add signed patches with either of the following commands:	
	Use the <code>patchadd</code> command in the Solaris 9 12/03 release.	"How to Automatically Download and Add a Signed Solaris Patch (<code>patchadd</code>)" on page 342
	Use the <code>smpatch</code> command in the Solaris 2.6, 7, 8, or 9 releases.	
	<code>smpatch</code> command – Prepare your system for this method.	"Preparation for Managing Signed Patches with <code>smpatch</code> Command (Task Map)" on page 343
	<code>smpatch</code> command – Add signed patches to your system.	"Managing Signed Patches With <code>smpatch</code> Command (Task Map)" on page 350
	Add an unsigned patch to your system.	"Managing Unsigned Solaris Patches (Task Map)" on page 356

Identifying Disk Space Requirements for Patches

Keep the following disk space considerations in mind before you begin downloading or spooling patches:

- The default download directory for signed patches is `/var/sadm/spool`. Unsigned patches that are spooled are also stored in `/var/sadm/spool`.
- The patch download process might use more disk space than anticipated because multiple patches can be downloaded, if prerequisite patches are required by the patch that you downloaded.
- Signed patches are unpacked in the `/var/sadm/spool` directory before they are installed. Be sure you have enough disk space in the `/var` directory for this process.

- If your `/var` directory is not large enough to support the downloading and unpacking of signed patches, you can use the `smpatch` command with the `-d` option to specify an alternate patch download directory.
- You can safely remove the patches from the `/var/sadm/spool` directory after they are successfully downloaded and added to your system to reclaim disk space in the `/var` directory.

Selecting Signed or Unsigned Patches for Your Environment

The key factor in determining when to add signed or unsigned patches is whether or not the secure download of patches is important in your environment. If the secure download of patches is important in your environment, then add signed patches to your system.

Adding Signed Patches With `patchadd` Command (Task Map)

Task	Description	For Instructions
1. Set up the package keystore	Import Sun's Root CA certificate into your package keystore.	"How to Import a Trusted Certificate into Your Package Keystore (<code>pkgadm addcert</code>)" on page 340
2. Download and add the signed patch	Select one of the following to download and add the signed patch to your system with the <code>patchadd</code> command.	
	You can manually download and add a signed Solaris patch.	"How to Manually Download and Add a Signed Solaris Patch (<code>patchadd</code>)" on page 341
	You can automatically download and add a signed Solaris patch.	"How to Automatically Download and Add a Signed Solaris Patch (<code>patchadd</code>)" on page 342

Task	Description	For Instructions
3. Add the signed patch	Add the signed patch with the <code>patchadd</code> command.	"How to Import Sun Certificates Into the Java Keystore" on page 347

How to Import a Trusted Certificate into Your Package Keystore (`pkgadm addcert`)

To add signed patches to your system with the `patchadd` command, you will need to add Sun's Root CA certificate, at the very least, to verify the signature on your signed patch. You can import this certificate from the Java keystore into the package keystore.

1. Become superuser or assume an equivalent role.
2. Export the Root CA certificate from the Java keystore into a temporary file.

For example:

```
# keytool -export -storepass changeit -alias gtecybertrustca -keystore
gtecybertrustca -keystore /usr/j2se/jre/lib/security/cacerts -file
/tmp/root.crt
Certificate stored in file </tmp/root.crt>
```

<code>-export</code>	Exports the trusted certificate.
<code>-storepass <i>storepass</i></code>	Specifies the password that protects the integrity of the Java keystore.
<code>-alias gtecybertrustca</code>	Identifies the alias of the trusted certificate.
<code>-keystore <i>certfile</i></code>	Specifies the name and location of the keystore file.
<code>-file <i>filename</i></code>	Identifies the file to hold the exported certificate.

3. Import the Root CA certificate into the package keystore from the temporary file.

For example:

```
# pkgadm addcert -t -f der /tmp/root.crt
Enter Keystore Password: storepass
  Keystore Alias: GTE CyberTrust Root
    Common Name: GTE CyberTrust Root
Certificate Type: Trusted Certificate
Issuer Common Name: GTE CyberTrust Root
Validity Dates: <Feb 23 23:01:00 1996 GMT>-<Feb 23 23:59:00 ...
MD5 Fingerprint: C4:D7:F0:B2:A3:C5:7D:61:67:F0:04:CD:43:D3:BA:58
SHA1 Fingerprint: 90:DE:DE:9E:4C:4E:9F:6F:D8:86:17:57:9D:D3:91...

Are you sure you want to trust this certificate? yes
Trusting certificate <GTE CyberTrust Root>
```

```
Type a Keystore protection Password.
Press ENTER for no protection password (not recommended):
For Verification: Type a Keystore protection Password.
Press ENTER for no protection password (not recommended):
Certificate(s) from </tmp/root.crt> are now trusted
```

<code>-t</code>	Indicates that the certificate is a trusted CA certificate. The command output includes the details of the certificate, which the user is asked to verify.
<code>-f format</code>	Specifies the format of the certificates or private key. When importing a certificate, it must be encoded using either the PEM (<code>pem</code>) or binary DER (<code>der</code>) format.
<code>certfile</code>	Specifies the file that contains the certificate.

4. Display the certificate information.

For example:

```
# pkgadm listcert -P pass:storepass
Keystore Alias: GTE CyberTrust Root
Common Name: GTE CyberTrust Root
Certificate Type: Trusted Certificate
Issuer Common Name: GTE CyberTrust Root
Validity Dates: <Feb 23 23:01:00 1996 GMT>-<Feb 23 23:59:00 2006 GMT>
MD5 Fingerprint: C4:D7:F0:B2:A3:C5:7D:61:67:F0:04:CD:43:D3:BA:58
SHA1 Fingerprint: 90:DE:DE:9E:4C:4E:9F:6F:D8:86:17:57:9D:D3:91:
BC:65:A6:89:64
```

5. Remove the temporary file.

For example:

```
# rm /tmp/root.crt
```

▼ How to Manually Download and Add a Signed Solaris Patch (`patchadd`)

You can use this procedure when you want to manually download the signed Solaris patch, and then add the signed Solaris patch in a separate step.

This procedure assumes that you have set up the package keystore.

1. (Optional) Log in to the system where the patch will be applied.

Or, you can download the patch and use the `ftp` command to copy the patch to the target system.

2. Open a web browser and go to the SunSolve Online Web site:

```
http://sunsolve.Sun.COM/pub-cgi/show.pl?target=patches/patch-access
```

3. **Determine if you are going to download a specific patch or patch cluster. Then select one of the following:**
 - a. **Type the patch number (*patch-ID*) in the “Find Patch” search field. Then, click on Find Patch.**
 Entering *patch-ID* downloads the latest patch revision.
 If this patch is freely available, the patch README is displayed. If this patch is not freely available, an ACCESS DENIED message is displayed.
 There are different patch numbers for SPARC and x86 systems, which are listed in the displayed patch README. Make sure you install the patch that matches your system architecture.
 - b. **Click on a recommended patch cluster based on the Solaris release running on the system to be patched.**
4. **Click the Download Signed Patch (*n* bytes) HTTPS or FTP button.**
 After the signed patch or patches are downloaded successfully, close the web browser.
5. **Change to the directory that contains the downloaded patch package, if necessary.**
6. **Become superuser or assume an equivalent role.**
7. **Add the signed patch.**
 For example:

```
# patchadd /tmp/114861-01.jar
```

▼ How to Automatically Download and Add a Signed Solaris Patch (`patchadd`)

You can use this procedure when you want to automatically download and add the signed Solaris patch in one step.

This procedure assumes that you have set up the package keystore.

1. **Become superuser or assume an equivalent role.**
2. **Download and add the signed patch or patches from the SunOnline web site.**

For example:

```
# patchadd "http://sunsolve.central.sun.com/cgi/patchDownload.pl?target=
114684&method=hs"
.
.
```

```

Downloading patch from ...
+ dwnld_file http://sunsolve.central.sun.com/cgi/patchDownload.pl?target=
114684&method=hs /tmp/patchadd-dwnld /var/sadm/security console patchadd
.....20%.....40%.....60%.....80%.....100%
## Downloading...
## Download Complete
.
.
Enter keystore password: xxx
.
.
.

```

Preparation for Managing Signed Patches with `smpatch` Command (Task Map)

Use this map to identify all the preparation tasks that are required before you can add signed patches to your system with the `smpatch` command.

Task	Description	For Instructions
1. Verify Solaris package requirements	Verify that the required Solaris packages are installed on your system to support the patch tools.	"How to Verify Package Requirements for Signed Patch Tools (<code>smpatch</code>)" on page 345
2. Download and install a Solaris patch management tool	Select a Solaris patch management tool based on your Solaris release.	"How to Download and Install the Solaris Patch Management Tools (<code>smpatch</code>)" on page 346
3. Import Sun certificates into the keystore	Import and accept the Sun certificates that are used to verify a patch's signature. The <code>SUNWcert</code> package is automatically installed when you install the signed patches tool. Do not install the <code>SUNWcert</code> package separately if you have already installed a signed patches tool.	"How to Import Sun Certificates Into the Java Keystore" on page 347
4. (Optional) Change the keystore password	Change the password to keep the keystore secure.	"How to Change the Java Keystore Password" on page 348

Task	Description	For Instructions
5. Set up your patch environment	Set up your system for adding signed patches.	"How to Set Up Your Patch Environment (smpatch)" on page 348

Using the Solaris Patch Management Tools (smpatch)

Keep the following key points in mind when using the Solaris patch management tools:

- Make sure your systems are currently up-to-date with patches, including the appropriate kernel update patches, Java patches, and the recommended patch clusters.
- You will have to manually import the Sun certificates used to verify a patch's signature after installing the Solaris patch management tools.
- **Solaris 2.6, 7, or 8 only** – If you have previous versions of the PatchPro software on your system, the older versions will be upgraded when Solaris Patch Manager Base Version 1.0 is installed.
- Install patches on a quiet system, preferably in single-user mode.
- Signed patches are verified when they are downloaded with the `smpatch download` command.

However, on a Solaris 9 system, no patch signature validation message is displayed during the patch download, even if the patch signature is successfully verified. If the patch signature verification fails, then the patch is not downloaded to your system.

- **Solaris 9 only** – The `smpatch` command prompts you for authentication information if you do not specify the authentication information in the `smpatch` command line.

For example, you can specify authentication information to the `smpatch` command using the following syntax:

```
# smpatch add -p mypassword -u root -- -i patch-ID
```

The `smpatch` subcommands (`add`, `analyze`, `download`, or `remove`) and the authentication options and arguments are separated by the subcommand arguments with `--`. Or, you can let the `smpatch` command prompt you for the authentication information. For example:

```
# /usr/sadm/bin/smpatch add -i patch-ID
Authenticating as user: root
```

```
Type /? for help, pressing <enter> accepts the default denoted by [ ]
Please enter a string value for: password ::
Loading Tool: com.sun.admin.patchmgr.cli.PatchMgrCli from starbug
Login to starbug as user root was successful.
```

Download of com.sun.admin.patchmgr.cli.PatchMgrCli from starbug was successful.

- Use the `/opt/SUNWppro/bin/uninstallpatchpro` script if you need to uninstall PatchPro 2.1. Do not attempt to remove PatchPro2.1 using this script if your current directory is `/opt/SUNWppro/bin`. Set your path as described in “How to Set Up Your Patch Environment (`smpatch`)” on page 348 and then run the `uninstallpatchpro` script from the root (`/`) directory, for example.

How to Verify Package Requirements for Signed Patch Tools (`smpatch`)

Make sure that you have the required Solaris packages installed on your system before you install the signed patch tools. If you are running the Solaris 2.6, 7, or 8 release, you need a minimal system configuration plus some additional packages. If you are running the Solaris 9 release, you must have the Developer cluster (`SUNWCprog`) installed on your system to use the signed patch tools.

1. Identify your Solaris release and select one of the following:

- a. If you are running the Solaris 2.6 release, identify whether the required packages are installed on your system:

```
# pkginfo | grep SUNWmfrun
system    SUNWmfrun    Motif RunTime Kit
# pkginfo | grep SUNWlibC
system    SUNWlibC     Sun Workshop Compilers Bundled libC
# pkginfo | grep SUNWxcu4
system    SUNWxcu4     XCU4 Utilities
```

- b. If you are running the Solaris 7 or 8 releases, identify whether the required packages are installed on your system:

```
# pkginfo | grep SUNWmfrm
system    SUNWmfrun    Motif RunTime Kit
# pkginfo | grep SUNWlibC
system    SUNWlibC     Sun Workshop Compilers Bundled libC
```

- c. If you are running the Solaris 9 release, verify that the required Developer cluster is installed on your system:

```
# cat /var/sadm/system/admin/CLUSTER
CLUSTER=SUNWCprog
```

2. If the `pkginfo` commands do not return any output, you need to install the required packages.

▼ How to Download and Install the Solaris Patch Management Tools (`smpatch`)

1. Become superuser.
2. Follow the links and download the appropriate tar file for your Solaris release from the following location:

`http://www.sun.com/PatchPro`

3. Select one of the following to unpack the patch tool package:
 - a. If you are running the Solaris 2.6 or 7 release, uncompress and unpack the package by using the following commands:
 - b. If you are running the Solaris 8 or 9 release, unpack the package by using the following command:

```
# uncompress SUNWpkg-name.tar.Z
# tar xvf SUNWpkg-name.tar
```

```
# gunzip -dc SUNWpkg-name.tar.gz | tar xvf -
```

4. Run the install script.

```
# cd unzipped-pkg-dir
# ./setup
```

If there are errors while running the install script, see “Troubleshooting Problems With Signed Patches (`smpatch`)” on page 354.

Examples—Downloading and Installing Solaris Patch Management Tools (`smpatch`)

This example shows how to download and install the Solaris 2.6 patch management tools.

```
# uncompress pproSunOSsparc5.6jre2.1.tar.Z
# tar xvf pproSunOSsparc5.6jre2.1.tar
.
.
.
# cd pproSunOSsparc5.6jre2.1
# ./setup
.
.
.
```

This example shows how to download and install the Solaris 9 patch management tools.

```
# gunzip -dc pproSunOSsparc5.9jre2.1.tar.gz | tar xvf -
.
```

```

.
# cd pproSunOSsparc5.9jre2.1
# ./setup
.
.
.

```

▼ How to Import Sun Certificates Into the Java Keystore

Use the `keytool` command to import and verify the Sun certificates that are used to verify the signed patches you want to add to your system. You must do this task even if you imported the certificates from a previous installation.

Note – The `SUNWcert` package is automatically installed when you install the signed patches tool. Do not install the `SUNWcert` package separately if you have already installed a signed patches tool.

1. Verify that you have completed the prerequisite task, which is to download one of the Solaris patch management tools.
2. Become superuser.
3. Determine the fingerprints of your Sun root certificate and Sun class B certificate.

```

# /usr/j2se/bin/keytool -printcert -file /etc/certs/SUNW/smrootcacert.b64
# /usr/j2se/bin/keytool -printcert -file /etc/certs/SUNW/smicacert.b64

```

4. Verify that the output of these commands matches the Sun root and class B certificate fingerprints displayed at:

<https://www.sun.com/pki/ca/>

5. Accept the Sun class B certificate by importing it into your system:

```

# /usr/j2se/bin/keytool -import -alias smiacert -file /etc/certs/SUNW/
smiacert.b64 -keystore /usr/j2se/jre/lib/security/cacerts
Enter keystore password:  changeit
Owner: O=Sun Microsystems Inc, CN=Sun Microsystems Inc CA (Class B)
Issuer: CN=Sun Microsystems Inc Root CA, O=Sun Microsystems Inc, C=US
Serial number: 1000006
Valid from: Mon Nov 13 12:23:10 MST 2000 until: Fri Nov 13 12:23:10 ...
Certificate fingerprints:
    MD5:  B4:1F:E1:0D:80:7D:B1:AB:15:5C:78:CB:C8:8F:CE:37
    SHA1: 1E:38:11:02:F0:5D:A3:27:5C:F9:6E:B1:1F:C4:79:95:E9:6E:D6:DF
Trust this certificate? [no]:  yes
Certificate was added to keystore

```

6. Accept the Sun root certificate by importing it into your system:

```
# /usr/j2se/bin/keytool -import -alias smirootcacert -file /etc/certs/SUNW/
smirootcacert.b64 -keystore /usr/j2se/jre/lib/security/cacerts
Enter keystore password: changeit
Owner: CN=Sun Microsystems Inc Root CA, O=Sun Microsystems Inc, C=US
Issuer: CN=GTE CyberTrust Root, O=GTE Corporation, C=US
Serial number: 200014a
Valid from: Tue Nov 07 15:39:00 MST 2000 until: Thu Nov 07 16:59:00 ...
Certificate fingerprints:
    MD5: D8:B6:68:D4:6B:04:B9:5A:EB:34:23:54:B8:F3:97:8C
    SHA1: BD:D9:0B:DA:AE:91:5F:33:C4:3D:10:E3:77:F0:45:09:4A:E8:A2:98
Trust this certificate? [no]: yes
Certificate was added to keystore
```

7. Accept the patch signing certificate by importing it into your system:

```
# /usr/j2se/bin/keytool -import -alias patchsigning -file /opt/SUNWppro/
etc/certs/patchsigningcert.b64 -keystore /usr/j2se/jre/lib/security/
cacerts
Enter keystore password: changeit
Owner: CN=Enterprise Services Patch Management, O=Sun Microsystems Inc
Issuer: O=Sun Microsystems Inc, CN=Sun Microsystems Inc CA (Class B)
Serial number: 1400007b
Valid from: Mon Sep 24 14:38:53 MDT 2001 until: Sun Sep 24 14:38:53 ...
Certificate fingerprints:
    MD5: 6F:63:51:C4:3D:92:C5:B9:A7:90:2F:FB:C0:68:66:16
    SHA1: D0:8D:7B:2D:06:AF:1F:37:5C:0D:1B:A0:B3:CB:A0:2E:90:D6:45:0C
Trust this certificate? [no]: yes
Certificate was added to keystore
```

▼ How to Change the Java Keystore Password

1. Become superuser.
2. Change the keystore password.

```
# /usr/j2se/bin/keytool -keystore /usr/j2se/jre/lib/security/
cacerts
Enter keystore password: changeit
New keystore password: new-password
Re-enter new keystore password: new-password
```

▼ How to Set Up Your Patch Environment (smpatch)

1. Become superuser.
2. Add patch tool directories to your path.

```
# PATH=/usr/sadm/bin:/opt/SUNWppro/bin:$PATH
# export PATH
```

3. (Optional) Identify the hardware on your system so that you can use the `smpatch analyze` command to determine whether you need specific patches based on your hardware configuration.

```
# pprosetup -H
```

```
Change Hardware Configuration.  
Analyzing this computer.  
.....
```

This command only identifies Sun's Network Storage products.

4. Identify the types of patches that you will be adding to the system.

```
# pprosetup -i standard:singleuser:rebootafter:reconfigafter
```

This command establishes the default patch policy for your system.

5. (Optional) If you want to add contract signed patches to your system, do the following steps to define your SunSolve username and password.

- a. Define your SunSolve username.

```
# pprosetup -u username
```

- b. Define your SunSolve password by adding the password to the following file:

```
/opt/SUNWppro/lib/.sunsolvepw
```

6. Identify a proxy server so that the patch tool can download patches to your system.

- a. If your system is behind a firewall, you need to define a proxy server that can access the `patchpro.sun.com` server and one of the following Sun patch servers that are used to download patches:

- `americas.patchmanager.sun.com` (default)
- `emea.patchmanager.sun.com`
- `japan.patchmanager.sun.com`

- b. Identify the selected proxy server by using the following command:

```
# pprosetup -x proxy-server:proxy-port
```

For example, if you selected `webaccess.corp.net.com` as the proxy server, the `pprosetup` command would look like this:

```
# pprosetup -x webaccess.corp.net.com:8080
```

Where to Go From Here

If you have completed all the signed patch preparation tasks, you can now add signed patches with the patch management tools.

Managing Signed Patches With `smpatch` Command (Task Map)

Task	Description	For Instructions
1. Perform signed patches preparation tasks	Perform all of the signed patches preparation tasks: <ul style="list-style-type: none">■ Verify package requirements for signed patch tools.■ Download and install the Solaris patch management tools.■ Import Sun certificates into the keystore.■ Change the keystore password.■ Set up your system for adding signed patches.	“Preparation for Managing Signed Patches with <code>smpatch</code> Command (Task Map)” on page 343
2. Download and add a signed patch or patches	Download and add a signed patch with the <code>smpatch</code> command.	“How to Download and Add a Signed Patch (<code>smpatch</code>)” on page 350
3. (Optional) Remove a signed patch	If necessary, remove an unsigned patch from your system.	“How to Remove a Signed Patch (<code>smpatch</code>)” on page 353

▼ How to Download and Add a Signed Patch (`smpatch`)

1. **Make sure you have completed the preparation tasks before downloading and adding a signed patch to your system. For more information, see “Preparation for Managing Signed Patches with `smpatch` Command (Task Map)” on page 343.**
2. **Become superuser.**
3. **Solaris 9 system only – Notify the Solaris Management Console server that the PatchPro packages were added to the system.**

```
# /etc/init.d/init.wbem stop  
# /etc/init.d/init.wbem start
```

4. **Download a signed patch or patches from the SunSolve web site.**

```
# smpatch download -i patch-ID
```

Requested patches:

patch-ID

Downloading the requested patches

/var/sadm/spool/patch-ID.jar has been validated.

For downloaded patch(es) see */var/sadm/spool*

5. Add the signed patch.

```
# smpatch add -i patch-ID
```

Examples—Downloading and Adding a Signed Patch (smpatch)

The following example shows how to download and add a signed patch with the `smpatch` command on a Solaris 9 system.

```
# /usr/sadm/bin/smpatch download -i 111711-01  
Authenticating as user: root
```

```
Type /? for help, pressing <enter> accepts the default denoted by [ ]  
Please enter a string value for: password :: xxx  
Loading Tool: com.sun.admin.patchmgr.cli.PatchMgrCli from starbug  
Login to starbug as user root was successful.  
Download of com.sun.admin.patchmgr.cli.PatchMgrCli from starbug was  
successful.
```

```
Requested patches:  
111711-01
```

```
Downloading the requested patches ...
```

For downloaded patch(es) see */var/sadm/spool*.

```
# smpatch add -i 111711-01  
Authenticating as user: root
```

```
Type /? for help, pressing <enter> accepts the default denoted by [ ]  
Please enter a string value for: password :: xxx  
Loading Tool: com.sun.admin.patchmgr.cli.PatchMgrCli from starbug  
Login to starbug as user root was successful.  
Download of com.sun.admin.patchmgr.cli.PatchMgrCli from starbug was  
successful.
```

```
On machine starbug ...  
Installing patch 111711-01
```

```
#
```

The following example shows how to download and add patch 105081–45 with the `smpatch` command on a Solaris 2.6 system.

```
# smpatch download -i 105407-01

Requested patches:

    105407-01

Downloading the requested patches

/var/sadm/spool/105407-01.jar has been validated.

For downloaded patch(es) see /var/sadm/spool
# smpatch add -i 105407-01
```

```
On machine "earth/172.20.27.27" ...
```

```
Installing patch 105407-01 ...
Purging /var/sadm/spool/105407-01
/var/sadm/spool/README.txt has been moved to
/var/sadm/spool/patchproSequester
```

The following example shows how to download and add patch 107081-45 with the `smpatch` command on a Solaris 7 system. This patch has two patch dependencies, which are automatically downloaded and verified.

```
# smpatch download -i 107081-45

Requested patches:

    107081-45

Downloading the requested patches

The following patches were added due to patch dependencies:
    108376-37
    107656-09
```

```
/var/sadm/spool/108376-37.jar has been validated.
```

```
/var/sadm/spool/107656-09.jar has been validated.
```

```
/var/sadm/spool/107081-45.jar has been validated.
```

```
For downloaded patch(es) see /var/sadm/spool
# smpatch add -i 108376-37 -i 107656-09 -i 107081-45
```

```
On machine "venus/172.20.27.26" ...
```

```
Installing patch 108376-37 ...
Installing patch 107656-09 ...
Installing patch 107081-45 ...
Purging /var/sadm/spool/108376-37
Purging /var/sadm/spool/107656-09
```



```
Purging /var/sadm/spool/107081-45
```

The following example shows how to use the `ftp` command to get a signed Solaris 8 patch from the SunSolve Online web site and then use the `smpatch add` command to add the signed patch to the system.

```
# ftp sunsolve.sun.com
Connected to sunsolve.sun.com.
220-
220-Welcome to the SunSolve Online FTP server.
220-
220-Public users may log in as anonymous.
.
.
.
Name (sunsolve.sun.com:root): anonymous
331 Guest login ok, send your complete e-mail address as password.
Password: xxx
230-
230-SUN MICROSYSTEMS, INC.
.
.
.230 Guest login ok, access restrictions apply.
ftp> cd signed_patches
250 CWD command successful.
ftp> get 112846-01.jar /var/sadm/spool/112846-01.jar
200 PORT command successful.
150 Opening ASCII mode data connection for 112846-01.jar (22524 bytes).
226 Transfer complete.
local: /var/sadm/spool/112846-01 remote: 112846-01.jar
22613 bytes received in 0.065 seconds (341.70 Kbytes/s)
ftp> quit
# smpatch add -i 112846-01
On machine "earth/172.20.27.27" ...

Installing patch 112846-01 ...
Purging /var/sadm/spool/112846-01
```

▼ How to Remove a Signed Patch (`smpatch`)

1. Become superuser.
2. Remove the signed patch.

```
# smpatch remove -i patch-ID
```

You cannot remove multiple patches in the same command.

Examples—Removing a Signed Patch (`smpatch`)

The following example shows how to remove a signed patch on a system running the Solaris 9 release.

```
# /usr/sadm/bin/smpatch remove -- -i 111711-01
Authenticating as user: root

Type /? for help, pressing <enter> accepts the default denoted by [ ]
Please enter a string value for: password ::
Loading Tool: com.sun.admin.patchmgr.cli.PatchMgrCli from starbug
Login to starbug as user root was successful.
Download of com.sun.admin.patchmgr.cli.PatchMgrCli from starbug was
successful.

      On machine starbug ...
          Removing patch 111711-01
```

The following example shows how to remove a signed patch on a system running the Solaris 2.6 release.

```
# smpatch remove -i 105407-01

On machine "earth/172.20.27.27" ...

Removing patch 105407-01

Checking installed patches...

Backing out patch 105407-01...

Patch 105407-01 has been backed out.
```

Troubleshooting Problems With Signed Patches (smpatch)

For up-to-date information on troubleshooting signed patch problems or error messages, see <http://sunsolve.Sun.COM/pub-cgi/show.pl?target=patches/spfaq>.

Viewing Patch Tool Log Files

Various log files on the system can identify problems with installing patch management tools or adding signed patches.

By default, PatchPro writes to the system log file. The syslog configuration file, `/etc/syslog.conf`, identifies where the system log file resides on the system. You can instruct PatchPro to write messages to a different file on the local file system by updating the `patchpro.log.file` property in the PatchPro configuration file, `/opt/SUNWppro/etc/patchpro.conf`.

For example, if you want PatchPro to write to the `/var/tmp/patchpro.log` file, assign `/var/tmp/patchpro.log` to the `patchpro.log` file property.

Use the following table to determine which log file might contain information about a failed installation of a patch management tool or a signed patch.

Log File	Description
<code>/var/tmp/ppro_install_log.nnn</code>	Identifies the success or failure of the installation of PatchPro packages and patches.
<code>/var/tmp/log/patchpro.log</code>	Identifies problems when adding a signed patch with the various patch tools.
<code>/var/adm/messages</code>	Can identify problems when adding a signed patch with the various patch tools or when the patch tools did not initialize properly.
Solaris Management Console 's Log Viewer on a Solaris 9 system	Identifies the success or failure of adding a signed patch with the Solaris Management Console's Patches tool.

▼ How to Resolve a Sequestered Patch

A patch might not install successfully if it requires prerequisite patches or if a system reboot is required to install the patch. Patches that cannot be installed by PatchPro are sequestered in the `/var/spool/pkg/patchproSequester` directory.

Review the patch README file to find out if there are any prerequisite patches, which are listed in a section called `REQUIRED PATCHES`.

You can either view a copy of the patch README from the SunSolve Online Web site or extract the README file from the JAR archive. Do not expand the JAR archive to avoid any tampering with the digital signature. Use the following procedure to safely extract the patch README file.

You should also review the contents of the `/var/tmp/log/patchpro.log` file to find out why a patch did not install successfully.

1. **Verify that a patch or patches were not installed by viewing the contents of the `/var/spool/pkg/patchproSequester` directory.**

```
# cd /var/spool/pkg/patchproSequester; ls
```

2. **Extract the README file from the JAR archive:**

- a. **First, identify the name of the README file. For example:**

```
# /usr/j2se/bin/jar tvf 107058-01.jar | grep README
```

b. Then, extract the **README** file. For example:

```
# /usr/j2se/bin/jar xvf 107058-01.jar 107058-01/README.107058-01
extracted: 107058-01/README.107058-01
```

3. View the **README** file.

For example:

```
# more 107058-01/README.107058-01
```

▼ How to Remove Imported Certificates From Java Keystore

If a problem occurred during the PatchPro installation, you might just remove the certificates and import them again.

1. Become superuser.

2. Remove the previously imported certificates.

```
#/usr/j2se/bin/keytool -delete -alias smicacert -keystore
/usr/j2se/jre/lib/security/cacerts
Enter keystore password: changeit
#/usr/j2se/bin/keytool -delete -alias smirootcacert -keystore
/usr/j2se/jre/lib/security/cacerts
Enter keystore password: changeit
#/usr/j2se/bin/keytool -delete -alias patchsigning -keystore
/usr/j2se/jre/lib/security/cacerts
Enter keystore password: changeit
```

Managing Unsigned Solaris Patches (Task Map)

Task	Description	For Instructions
1. (Optional) Display information about unsigned patches	Display information about unsigned patches already installed on your system.	"How to Display Information About Solaris Patches" on page 357
2. Download an unsigned patch	Download an unsigned patch to your system.	"How to Download an Unsigned Solaris Patch" on page 358

Task	Description	For Instructions
3. Add an unsigned patch	Add an unsigned patch to your system.	“How to Add a Unsigned Solaris Patch” on page 359
4. (Optional) Remove an unsigned patch	If necessary, remove an unsigned patch from your system.	“Managing Signed Patches With <code>smpatch</code> Command (Task Map)” on page 350

Displaying Information About Unsigned Solaris Patches

Before installing patches, you might want to know more about patches that have previously been installed. The following table describes commands that provide useful information about patches that are already installed on a system.

TABLE 25-1 Commands for Solaris Patch Management

Command	Description
<code>patchadd -p, showrev -p</code>	Shows all patches that have been applied to a system.
<code>pkgparam <i>pkgid</i> PATCHLIST</code>	Shows all patches that have been applied to the package identified by <i>pkgid</i> , the name of the package. For example, <code>SUNWadmap</code> .
<code>patchadd -s Solaris-OS -p</code>	Shows all the <code>/usr</code> patches installed on an OS server.

How to Display Information About Solaris Patches

Use the `patchadd -p` command to display information about patches installed on your system.

```
$ patchadd -p
```

Use the following command to verify whether a specific patch is installed on your system. For example:

```
$ patchadd -p | grep 111879
```

Adding an Unsigned Solaris Patch

You can use the `patchadd` command to add unsigned patches to servers or standalone systems. If you need to add a patch to a diskless client system, see “Patching Diskless Client OS Services” on page 138.

When you add a patch, the `patchadd` command calls the `pkgadd` command to install the patch packages from the patch directory to a local system's disk. More specifically, the `patchadd` command:

- Determines the Solaris version number of the managing host and the target host
- Updates the patch package's `pkginfo` file with information about patches obsoleted by the patch being installed, other patches required by this patch, and patches incompatible with this patch

During patch installation, the `patchadd` command keeps a log of the patch installation in the `/var/sadm/patch/patch-ID/log` file for current Solaris versions.

The `patchadd` command will not install a patch under the following conditions:

- The package is not fully installed on the host.
- The patch packages architecture differs from the system's architecture.
- The patch packages version does not match the installed package's version.
- A patch with the same base code and a higher version number is already installed.
- The patch is incompatible with another, already installed patch. Each installed patch keeps this information in its `pkginfo` file.
- The patch being installed requires another patch that is not installed

▼ How to Download an Unsigned Solaris Patch

1. **(Optional) Log in to the system where the patch will be applied.**

Or, you can download the patch and use the `ftp` command to copy the patch to the target system.

2. **Open a web browser and go to the SunSolve Online web site:**

<http://sunsolve.Sun.COM/pub-cgi/show.pl?target=patches/patch-access>

3. **Determine if you are going to download a specific patch or patch cluster. Then select one of the following:**

- a. **Type the patch number (*patch-ID*) in the "Find Patch" search field. Then, click on Find Patch.**

Entering *patch-ID* downloads the latest patch revision.

If this patch is freely available, the patch README is displayed. If this patch is not freely available, an ACCESS DENIED message is displayed.

There are different patch numbers for SPARC and x86 systems, which are listed in the displayed patch README. Make sure you install the patch that matches your system architecture.

- b. **Click on a recommended patch cluster based on the Solaris release running on the system to be patched.**

4. Click the **Download Patch** (*n* bytes) **HTTP or FTP** button.
After the patch or patches are downloaded successfully, close the web browser.
5. **Change to the directory that contains the downloaded patch package, if necessary.**
6. **Unzip the patch package.**

```
% unzip patch-ID-revision
```

▼ How to Add a Unsigned Solaris Patch

1. **Become superuser.**
2. **Add the patch or patches.**

```
# patchadd patch-ID-revision
```
3. **Verify that the patch was added successfully.**

```
# patchadd -p | grep patch-ID-revision
```

Example—Adding an Unsigned Solaris Patch

In the following example, the Solaris 8 patch, 111879-01, is added to the system. The patch had already been downloaded to the system previously.

```
# patchadd /export/Sol8patch/111879-01

Checking installed patches...
Verifying sufficient filesystem capacity (dry run method)...
Installing patch packages...

Patch number 111879-01 has been successfully installed.
See /var/sadm/patch/111879-01/log for details

Patch packages installed:
SUNWwsr
# patchadd -p | grep 111879-01
Patch: 111879-01 Obsoletes: Requires: Incompatibles: Packages: SUNWwsr
```

Removing an Unsigned Solaris Patch

When you back out a patch, the `patchrm` command restores all files modified by that patch, unless:

- The patch was installed with the `patchadd -d` option, which instructs `patchadd` to not save copies of files being updated or replaced.

- The patch has been obsoleted by a later patch.
- The patch is required by another patch.

The `patchrm` command calls the `pkgadd` command to restore packages that were saved from the initial patch installation.

During the patch removal process, `patchrm` keeps a log of the back out process in `/tmp/backoutlog.process_id`. This log file is removed if the patch backs out successfully.

▼ How to Remove an Unsigned Solaris Patch

Use the `patchrm` command if you need to remove an unsigned Solaris patch.

1. Become superuser.

2. Remove the patch.

```
# patchrm patch-ID-revision
```

3. Verify that the patch was removed.

```
# patchadd -p | grep patch-ID-revision
```

Example—Removing an Unsigned Solaris Patch

The following example shows how to remove the Solaris 8 patch, 111879–01.

```
# patchrm 111879-01

Checking installed patches...

Backing out patch 111879-01...

Patch 111874-02 has been backed out.

# showrev -p | grep 111879-01
#
```

Managing Devices Topics

This topic map lists the chapters that provide information on managing devices.

Chapter 27	Provides a high-level overview of device configuration and step-by-step instructions for displaying device information on your system.
Chapter 28	Provides step-by-step instructions for configuring devices.
Chapter 29	Provides a high-level overview of USB devices and step-by-step instructions for using USB devices.
Chapter 30	Provides an overview of device naming conventions and instructions for accessing devices.

Managing Devices (Tasks)

This chapter provides overview information and step-by-step instructions for managing peripheral devices, such as disks, CD-ROMs, and tape devices, in the Solaris environment.

This is a list of the step-by-step instructions in this chapter.

- “How to Display System Configuration Information” on page 368
- “How to Display Device Information” on page 369
- “How to Add a Device Driver” on page 372
- “How to Add a Peripheral Device” on page 371

This is a list of the overview information in this chapter.

- “Where to Find Device Management Tasks” on page 363
- “About Device Drivers” on page 364
- “Automatic Configuration of Devices” on page 364
- “Displaying Device Configuration Information” on page 366

For information about accessing peripheral devices, see Chapter 30.

Device management in the Solaris environment usually involves adding and removing peripheral devices from systems, possibly adding a third-party device driver to support a device, and displaying system configuration information.

Where to Find Device Management Tasks

The following table describes where to find step-by-step instructions for hot-plugging devices and adding serial devices, such as printers and modems, and peripheral devices, such as a disk, CD-ROM, or tape devices.

TABLE 27-1 Where to Find Instructions for Adding a Device

Device Management Task	For More Information
Adding a disk that is not hot-pluggable	Chapter 34 or Chapter 35
Hot-plugging a SCSI or PCI device	"SCSI Hot-Plugging With the <code>cfgadm</code> Command" on page 378 or "x86: PCI Hot-Plugging With the <code>cfgadm</code> Command" on page 388
Hot-plugging a USB device	"Hot-Plugging USB Devices" on page 410
Adding a CD-ROM or tape device	"How to Add a Peripheral Device" on page 371
Adding a modem	"Managing Terminals and Modems (Overview)" in <i>System Administration Guide: Advanced Administration</i>
Adding a printer	"Managing Printing Services (Overview)" in <i>System Administration Guide: Advanced Administration</i>

About Device Drivers

A computer typically uses a wide range of peripheral and mass-storage devices. Your system, for example, probably has a disk drive, a keyboard and a mouse, and some kind of magnetic backup medium. Other commonly used devices include CD-ROM drives, printers and plotters, light pens, touch-sensitive screens, digitizers, and tablet-and-stylus pairs.

The Solaris software does not directly communicate with all these devices. Each type of device requires different data formats, protocols, and transmission rates.

A *device driver* is a low-level program that allows the operating system to communicate with a specific piece of hardware. The driver serves as the operating system's "interpreter" for that piece of hardware.

Automatic Configuration of Devices

The kernel, consisting of a small generic core with a platform-specific component and a set of modules, is configured automatically in the Solaris environment.

A kernel module is a hardware or software component that is used to perform a specific task on the system. An example of a *loadable* kernel module is a device driver that is loaded when the device is accessed.

The platform-independent kernel is `/kernel/genunix`. The platform-specific component is `/platform/`uname -m`/kernel/unix`.

The kernel modules are described in the following table.

TABLE 27-2 Description of Kernel Modules

Location	Directory Contents
<code>/platform/`uname -m`/kernel</code>	Platform-specific kernel components
<code>/kernel</code>	Kernel components common to all platforms that are needed for booting the system
<code>/usr/kernel</code>	Kernel components common to all platforms within a particular instruction set

The system determines what devices are attached to it at boot time. Then, the kernel configures itself dynamically, loading needed modules into memory. At this time, device drivers are loaded when devices, such as disk and tape devices, are accessed. This process is called *autoconfiguration* because all kernel modules are loaded automatically when they are needed.

You can customize the way in which kernel modules are loaded by modifying the `/etc/system` file. For instructions on modifying this file, see `system(4)`.

Features and Benefits of Autoconfiguration

The benefits of autoconfiguration are as follows:

- Main memory is used more efficiently because modules are loaded when needed.
- There is no need to reconfigure the kernel when new devices are added to the system.
- Drivers can be loaded and tested without having to rebuild the kernel and reboot the system.

You will use autoconfiguration is used by a system administrator when you add a new device (and driver) to the system. At this time, you will perform a reconfiguration boot so that the system will recognize the new device.

What You Need for Unsupported Devices

Device drivers needed to support a wide range of standard devices are included in the Solaris environment. These drivers can be found in the `/kernel/drv` and `/platform/`uname -m`/kernel/drv` directories.

However, if you've purchased an unsupported device, the manufacturer should provide the software that is needed for the device to be properly installed, maintained, and administered.

At a minimum, this software includes a device driver and its associated configuration (.conf) file. The .conf files reside in the drv directories. This software might also include custom maintenance and administrative utilities since the device might be incompatible with Solaris utilities.

Contact your device manufacturer for more information.

Displaying Device Configuration Information

Three commands are used to display system and device configuration information.

Command	Man Page	Description
prtconf	prtconf(1M)	Displays system configuration information, including total amount of memory and the device configuration as described by the system's device hierarchy. The output displayed by this command depends upon the type of system.
sysdef	sysdef(1M)	Displays device configuration information including system hardware, pseudo devices, loadable modules, and selected kernel parameters.
dmesg	dmesg(1M)	Displays system diagnostic messages as well as a list of devices attached to the system since the last reboot.

For information on the device names that are used to identify devices on the system, see "Device Naming Conventions" on page 430.

driver not attached Message

The following driver-related message might be displayed by the prtconf and sysdef commands:

device, instance #*number* (driver not attached)

This message does not always mean that a driver is unavailable for this device. This message means that no driver is *currently* attached to the device instance because there is no device at this node or the device is not in use. Drivers are loaded automatically when the device is accessed and unloaded when the device is not in use.

Identifying a System's Devices

Use the output of the `prtconf` and `sysdef` commands to identify which disk, tape, and CD-ROM devices are connected to the system. The output of these commands display the driver not attached messages next to the device instances. Since these devices are always being monitored by some system process, the driver not attached message is usually a good indication that there is no device at that device instance.

For example, the following `prtconf` output identifies a device at instance #3 and instance #6, which is probably a disk device at target 3 and a CD-ROM device at target 6 of the first SCSI host adapter (`esp`, instance #0).

```
$ /usr/sbin/prtconf
.
.
.
esp, instance #0
    sd (driver not attached)
    st (driver not attached)
    sd, instance #0 (driver not attached)
    sd, instance #1 (driver not attached)
    sd, instance #2 (driver not attached)
    sd, instance #3
    sd, instance #4 (driver not attached)
    sd, instance #5 (driver not attached)
    sd, instance #6
.
.
.
```

You can use the following command to display only the devices that are attached to the system.

```
$ prtconf | grep -v not
```

You can also glean device information from the `sysdef` output.

How to Display System Configuration Information

Use the `prtconf` command to display system configuration information.

```
# /usr/sbin/prtconf
```

Use the `sysdef` command to display system configuration information that include pseudo devices, loadable modules, and selected kernel parameters.

```
# /usr/sbin/sysdef
```

Examples—Displaying System Configuration Information

The following `prtconf` output is displayed on a SPARC based system.

```
# prtconf
System Configuration: Sun Microsystems sun4u
Memory size: 128 Megabytes
System Peripherals (Software Nodes):
SUNW,Ultra-5_10
  packages (driver not attached)
    terminal-emulator (driver not attached)
    deblocker (driver not attached)
    obp-tftp (driver not attached)
    disk-label (driver not attached)
    SUNW,builtin-drivers (driver not attached)
    sun-keyboard (driver not attached)
    ufs-file-system (driver not attached)
  chosen (driver not attached)
  openprom (driver not attached)
    client-services (driver not attached)
  options, instance #0
  aliases (driver not attached)
  memory (driver not attached)
  virtual-memory (driver not attached)
  pci, instance #0
    pci, instance #0
      ebus, instance #0
        auxio (driver not attached)
        power, instance #0
        SUNW,pll (driver not attached)
        se, instance #0
        su, instance #0
        su, instance #1
        ecpp (driver not attached)
        fdthree, instance #0
  .
  .
  .
```

The following `sysdef` output is displayed from an x86 based system.

```
# sysdef
* Hostid
```



```

*
  29f10b4d
*
* i86pc Configuration
*
*
* Devices
*
+boot (driver not attached)
memory (driver not attached)
aliases (driver not attached)
chosen (driver not attached)
i86pc-memory (driver not attached)
i86pc-mmio (driver not attached)
openprom (driver not attached)
options, instance #0
packages (driver not attached)
delayed-writes (driver not attached)
itu-props (driver not attached)
isa, instance #0
  motherboard (driver not attached)
  pnpADP,1542, instance #0
  asy, instance #0
  asy, instance #1
  lp, instance #0 (driver not attached)
  fdc, instance #0
    fd, instance #0
    fd, instance #1 (driver not attached)
  kd (driver not attached)
  kdmouse (driver not attached)
.
.
.

```

How to Display Device Information

Display device information with the `dmesg` command.

```
# /usr/sbin/dmesg
```

The `dmesg` output is displayed as messages on the system console and identifies which devices are connected to the system since the last reboot.

Examples—Displaying Device Information

The following `dmesg` output is displayed from a SPARC based system.

```
# dmesg
Jan  3 08:44:41 starbug genunix: [ID 540533 kern.notice] SunOS Release 5.9 ...
Jan  3 08:44:41 starbug genunix: [ID 913631 kern.notice] Copyright 1983-2002 ...
```

```
Jan 3 08:44:41 starbug genunix: [ID 678236 kern.info] Ethernet address = ...
Jan 3 08:44:41 starbug unix: [ID 389951 kern.info] mem = 131072K (0x8000000)
Jan 3 08:44:41 starbug unix: [ID 930857 kern.info] avail mem = 121888768
Jan 3 08:44:41 starbug rootnex: [ID 466748 kern.info] root nexus =
Sun Ultra 5/10 UPA/PCI (UltraSPARC-IIi 333MHz)
.
.
.
#
```

The following dmesg output is displayed from an x86 based system.

```
# dmesg
Jan 2 07:21:46 naboo genunix: [ID 540533 kern.notice] SunOS Release 5.9 Version ...
Jan 2 07:21:46 naboo genunix: [ID 913631 kern.notice] Copyright 1983-2002 ...
Jan 2 07:21:46 naboo genunix: [ID 897550 kern.info] Using default device ...
Jan 2 07:21:46 naboo unix: [ID 168242 kern.info] mem = 130684K (0x7f9f000)
Jan 2 07:21:46 naboo unix: [ID 930857 kern.info] avail mem = 116547584
Jan 2 07:21:46 naboo rootnex: [ID 466748 kern.info] root nexus = i86pc
Jan 2 07:21:46 naboo rootnex: [ID 349649 kern.info] pci0 at root: ...
Jan 2 07:21:46 naboo genunix: [ID 936769 kern.info] pci0 is /pci@0,0
Jan 2 07:21:46 naboo genunix: [ID 678236 kern.info] Ethernet address = ...
.
.
.
```

Adding a Peripheral Device to a System

Adding a new (non-hot-pluggable) peripheral device usually involves the following:

- Shutting down the system
- Connecting the device to the system
- Rebooting the system

Use the “How to Add a Peripheral Device” on page 371 procedure to add the following devices that are not hot-pluggable to a system:

- CD-ROM
- Secondary disk drive
- Tape drive
- SBUS card

In some cases, you might have to add a third-party device driver to support the new device.

For information on hot-plugging devices, see Chapter 28.

▼ How to Add a Peripheral Device

1. Become superuser.
2. Follow steps 2 and 3 of “How to Add a Device Driver” on page 372 if you need to add a device driver to support the device.
3. Create the `/reconfigure` file.

```
# touch /reconfigure
```

The `/reconfigure` file will cause the Solaris software to check for the presence of any newly installed devices the next time you turn on or boot your system.

4. Shut down the system.

```
# shutdown -i0 -g30 -y
```

`-i0` Brings the system to the 0 init state, which is the appropriate state for turning the system power off for adding and removing devices.

`-g30` Shuts the system down in 30 seconds. The default is 60 seconds.

`-y` Continues the system shutdown without user intervention. Otherwise, you are prompted to continue the shutdown process.

5. Select one of the following to turn off power to the system after it is shut down.
 - a. For SPARC platforms, it is safe to turn off power if the `ok` prompt is displayed.
 - b. For x86 platforms, it is safe to turn off power if the `type any key to continue` prompt is displayed.

Refer to the hardware installation guide that accompanies your system for the location of the power switch.

6. Turn off power to all external devices.

For the location of power switches on any peripheral devices, refer to the hardware installation guides that accompany your peripheral devices.

7. Install the peripheral device, making sure that the device you are adding has a different target number than the other devices on the system.

You often will find a small switch located at the back of the disk for selecting the target number.

Refer to the hardware installation guide that accompanies the peripheral device for information on installing and connecting the device.

8. **Turn on the power to the system.**

The system boots to multiuser mode and the login prompt is displayed.

9. **Verify that the peripheral device has been added by attempting to access the device.**

For information on accessing the device, see Chapter 30.

▼ How to Add a Device Driver

This procedure assumes that the device has already been added to the system. If not, see “What You Need for Unsupported Devices” on page 365.

1. **Become superuser.**

2. **Place the tape, diskette, or CD-ROM into the drive.**

3. **Install the driver.**

```
# pkgadd -d device package-name
```

-d device

Identifies the device path name that contains the package.

package-name

Identifies the package name that contains the device driver.

4. **Verify that the package has been added correctly.**

```
# pkgchk package-name  
#
```

The system prompt returns with no response if the package is installed correctly.

Example—Adding a Device Driver

The following example shows how to install and verify a package called XYZdrv.

```
# pkgadd XYZdrv  
(licensing messages displayed)  
.  
.  
.  
Installing XYZ Company driver as <XYZdrv>  
.  
.  
.  
Installation of <XYZdrv> was successful.  
# pkgchk XYZdrv  
#
```

Dynamically Configuring Devices (Tasks)

This chapter provides instructions for dynamically configuring devices in the Solaris environment. You can add, remove, or replace devices in the Solaris environment while the system is still running, if the system components support hot-plugging. If the system components do not support hot-plugging, you can reboot the system to reconfigure the devices.

For information on the procedures associated with dynamically configuring devices, see the following:

- “SCSI Hot-Plugging With the `cfgadm` Command (Task Map)” on page 377
- “PCI Hot-Plugging With the `cfgadm` Command (Task Map)” on page 387
- “Application Developer RCM Script (Task Map)” on page 393
- “System Administrator RCM Script (Task Map)” on page 394

For information on hot-plugging USB devices with the `cfgadm` command, see “Hot-Plugging USB Devices With the `cfgadm` Command” on page 424.

For information about accessing devices, see Chapter 30.

Dynamic Reconfiguration and Hot-Plugging

Hot-plugging is the ability to physically add, remove, or replace system components while the system is running. *Dynamic reconfiguration* refers to the ability to hot-plug system components. This term also refers to the general ability to move system resources (both hardware and software) around in the system or to disable them in some way without physically removing them from the system.

You can hot-plug the following devices with the `cfgadm` command:

- USB devices on SPARC and x86 platforms
- SCSI devices on SPARC and x86 platforms
- PCI devices on x86 platforms

Features of the `cfgadm` command include the following:

- Displaying system component status
- Testing system components
- Changing component configurations
- Displaying configuration help messages

The benefit of using the `cfgadm` command to reconfigure systems components is that you can add, remove, or replace components while the system is running. An added benefit is that the `cfgadm` command guides you through the steps needed to add, remove, or replace system components.

For step-by-step instructions on hot-plugging SCSI components, see `cfgadm(1M)` and “SCSI Hot-Plugging With the `cfgadm` Command” on page 378. For step-by-step instructions on hot-plugging PCI adapter cards on x86 based systems, see “x86: PCI Hot-Plugging With the `cfgadm` Command” on page 388.

Note – Not all SCSI and PCI controllers support hot-plugging with the `cfgadm` command.

As part of Sun’s high availability strategy, dynamic reconfiguration is expected to be used in conjunction with additional layered products, such as alternate pathing or fail-over software. Both products provide fault tolerance in the event of a device failure.

Without any high availability software, you can replace a failed device by manually stopping the appropriate applications, unmounting noncritical file systems, and then proceeding with the add or remove operations.

Note – For information about hot-plugging devices on your specific hardware configuration, such as enterprise-level systems, please refer to your hardware configuration documentation.

Attachment Points

The `cfgadm` command displays information about *attachment points*, which are locations in the system where dynamic reconfiguration operations can occur.

An attachment point consists of the following:

- An *occupant*, which represents a hardware component that can be configured into the system
- A *receptacle*, which is the location that accepts the occupant

Attachment points are represented by logical and physical attachment point IDs (`Ap_Ids`). The physical `Ap_Id` is the physical pathname of the attachment point. The logical `Ap_Id` is a user-friendly alternative for the physical `Ap_Id`. For more information on `Ap_Ids`, refer to `cfgadm(1M)`.

The logical `Ap_Id` for a SCSI Host Bus Adapter (HBA), or SCSI controller, is usually represented by the controller number, such as `c0`.

In cases where no controller number has been assigned to a SCSI HBA, then an internally-generated unique identifier is provided. An example of a unique identifier for a SCSI controller is the following:

```
fas1:scsi
```

The logical `Ap_Id` for a SCSI device usually looks like this:

```
HBA-logical-apid::device-identifier
```

In the following example, `c0` is the logical `Ap_Id` for the SCSI HBA:

```
c0::dsk/c0t3d0
```

The device identifier is typically derived from the logical device name for the device in the `/dev` directory. For example, a tape device with logical device name, `/dev/rmt/1`, has the following logical `Ap_Id`:

```
c0::rmt/1
```

If a logical `Ap_Id` of a SCSI device cannot be derived from the logical name in the `/dev` directory, then an internally-generated unique identifier is provided. An example of an identifier for the `/dev/rmt/1` tape device is the following:

```
c0::st4
```

For more information on SCSI `Ap_Ids`, refer to `cfgadm_scsi(1M)`.

The `cfgadm` command represents all resources and dynamic reconfiguration operations in terms of a common set of states (such as configured, unconfigured) and operations (connect, configure, unconfigure, and so on). For more information on these common states and operations, see `cfgadm(1M)`.

The receptacle and occupant states for the SCSI HBA attachment points are as follows:

Receptacle State	Description	Occupant State	Description
empty	N/A for SCSI HBA	configured	One or more devices configured on the bus
disconnected	Bus quiesced	unconfigured	No devices configured
connected	Bus active		

Receptacle and occupant states for SCSI device attachment points are as follows:

Receptacle State	Description	Occupant State	Description
empty	N/A for SCSI devices	configured	Device is configured
disconnected	Bus quiesced	unconfigured	Device is not configured
connected	Bus active		

The state of SCSI attachment points is unknown unless there is special hardware to indicate otherwise. For instructions on displaying SCSI component information, see “How to Display Information About SCSI Devices” on page 378.

x86: Detaching PCI Adapter Cards

A PCI adapter card that is hosting nonvital system resources can be removed if the device driver supports hot-plugging. A PCI adapter card is not detachable if it is a vital system resource. For a PCI adapter card to be detachable the following conditions must be met:

- The device driver must support hot-plugging.
- Critical resources must be accessible through an alternate pathway.

For example, if a system has only one Ethernet card installed in it, the Ethernet card cannot be detached without losing the network connection. This detachment requires additional layered software support to keep the network connection active.

x86: Attaching PCI Adapter Cards

A PCI adapter card can be added to the system as long as the following conditions are met:

- There are slots available.
- The device driver supports hot-plugging for this adapter card.

For step-by-step instructions on adding or removing a PCI adapter card, see “x86: PCI Hot-Plugging With the `cfgadm` Command” on page 388.

SCSI Hot-Plugging With the `cfgadm` Command (Task Map)

Task	Description	For Instructions
1. Display information about SCSI devices	Display information about SCSI controllers and devices.	"How to Display Information About SCSI Devices" on page 378
2. Unconfigure a SCSI controller	Unconfigure a SCSI controller.	"How to Unconfigure a SCSI Controller" on page 379
3. Configure a SCSI controller	Configure a SCSI controller that was previously unconfigured.	"How to Configure a SCSI Controller" on page 379
4. Configure a SCSI device	Configure a specific SCSI device.	"How to Configure a SCSI Device" on page 380
5. Disconnect a SCSI controller	Disconnect a specific SCSI controller.	"How to Disconnect a SCSI Controller" on page 381
6. Connect a SCSI controller	Connect a specific SCSI controller that was previously disconnected.	"SPARC: How to Connect a SCSI Controller" on page 382
7. Add a SCSI device to a SCSI bus	Add a specific SCSI device to a SCSI bus.	"SPARC: How to Add a SCSI Device to a SCSI Bus" on page 382
8. Replace an identical device on a SCSI controller	Replace a device on the SCSI bus with another device of the same type.	"SPARC: How to Replace an Identical Device on a SCSI Controller" on page 383
9. Remove a SCSI device	Remove a SCSI device from the system.	"SPARC: How to Remove a SCSI Device" on page 384
10. Troubleshooting SCSI configuration problems	Resolve a failed SCSI unconfigure operation.	"How to Resolve a Failed SCSI Unconfigure Operation" on page 387

SCSI Hot-Plugging With the `cfgadm` Command

This section describes various SCSI hot-plugging procedures that you can perform with the `cfgadm` command.

These procedures use specific devices as examples to illustrate how to use the `cfgadm` command to hot-plug SCSI components. The device information that you supply, and that the `cfgadm` command displays, depends on your system configuration.

▼ How to Display Information About SCSI Devices

The following procedure uses SCSI controllers `c0` and `c1` and the devices that are attached to them as examples of the type of device configuration information that you can display with the `cfgadm` command.

Note – If the SCSI device is not supported by the `cfgadm` command, it does not display in the `cfgadm` command output.

1. Become superuser.

2. Display information about attachment points on the system.

```
# cfgadm -l
Ap_Id                Type          Receptacle  Occupant    Condition
c0                   scsi-bus     connected   configured  unknown
c1                   scsi-bus     connected   configured  unknown
```

In this example, `c0` and `c1` represent two SCSI controllers.

3. Display information about a system's SCSI controllers and their attached devices.

```
# cfgadm -al
Ap_Id                Type          Receptacle  Occupant    Condition
c0                   scsi-bus     connected   configured  unknown
c0::disk/c0t0d0     disk         connected   configured  unknown
c0::rmt/0           tape         connected   configured  unknown
c1                   scsi-bus     connected   configured  unknown
c1::disk/c1t3d0     disk         connected   configured  unknown
c1::disk/c1t4d0     unavailable  connected   unconfigured unknown
```

Note – The `cfgadm -l` command displays information about SCSI HBAs but not SCSI devices. Use the `cfgadm -al` command to display information about SCSI devices such as disk and tapes.

In the following procedures, only SCSI attachment points are listed. The attachment points that are displayed on your system depend on your system configuration.

▼ How to Unconfigure a SCSI Controller

The following procedure uses SCSI controller `c1` as an example of unconfiguring a SCSI controller.

1. **Become superuser.**
2. **Unconfigure a SCSI controller.**

```
# cfgadm -c unconfigure c1
```

3. **Verify that the SCSI controller is unconfigured.**

```
# cfgadm -al
Ap_Id                Type           Receptacle  Occupant    Condition
c0                   scsi-bus      connected   configured  unknown
c0::disk/c0t0d0     disk          connected   configured  unknown
c0::rmt/0            tape          connected   configured  unknown
c1                   scsi-bus      connected   unconfigured unknown
```

Notice that the `Occupant` column for `c1` specifies `unconfigured`, indicating that the SCSI bus has no configured occupants.

If the unconfigure operation fails, see “How to Resolve a Failed SCSI Unconfigure Operation” on page 387.

▼ How to Configure a SCSI Controller

The following procedure uses SCSI controller `c1` as an example of configuring a SCSI controller.

1. **Become superuser.**
2. **Configure a SCSI controller.**

```
# cfgadm -c configure c1
```

3. **Verify that the SCSI controller is configured.**

```
# cfgadm -al
Ap_Id                Type           Receptacle  Occupant    Condition
```

c0	scsi-bus	connected	configured	unknown
c0::dsk/c0t0d0	disk	connected	configured	unknown
c0::rmt/0	tape	connected	configured	unknown
c1	scsi-bus	connected	configured	unknown
c1::dsk/c1t3d0	disk	connected	configured	unknown
c1::dsk/c1t4d0	unavailable	connected	unconfigured	unknown

The previous unconfigure procedure removed all devices on the SCSI bus. Now all the devices are configured back into the system.

▼ How to Configure a SCSI Device

The following procedure uses SCSI disk `c1t4d0` as an example of configuring a SCSI device.

1. **Become superuser.**
2. **Identify the device to be configured.**

```
# cfgadm -al
```

Ap_Id	Type	Receptacle	Occupant	Condition
c0	scsi-bus	connected	configured	unknown
c0::dsk/c0t0d0	disk	connected	configured	unknown
c0::rmt/0	tape	connected	configured	unknown
c1	scsi-bus	connected	configured	unknown
c1::dsk/c1t3d0	disk	connected	configured	unknown
c1::dsk/c1t4d0	unavailable	connected	unconfigured	unknown

3. **Configure the SCSI device.**

```
# cfgadm -c configure c1::dsk/c1t4d0
```

4. **Verify that the SCSI device is configured.**

```
# cfgadm -al
```

Ap_Id	Type	Receptacle	Occupant	Condition
c0	scsi-bus	connected	configured	unknown
c0::dsk/c0t0d0	disk	connected	configured	unknown
c0::rmt/0	tape	connected	configured	unknown
c1	scsi-bus	connected	configured	unknown
c1::dsk/c1t3d0	disk	connected	configured	unknown
c1::dsk/c1t4d0	disk	connected	configured	unknown

▼ How to Disconnect a SCSI Controller



Caution – Disconnecting a SCSI device must be done with caution, particularly when you are dealing with controllers for disks that contain critical file systems such as root (/), *usr*, *var*, and the swap partition. The dynamic reconfiguration software cannot detect all cases where a system hang might result. Use this procedure with caution.

The following procedure uses SCSI controller *c1* as an example of disconnecting a SCSI device.

1. Become superuser.

2. Verify that the device is connected before you disconnect it.

```
# cfgadm -al
Ap_Id                Type                Receptacle  Occupant  Condition
c0                   scsi-bus           connected   configured unknown
c0::dsk/c0t0d0       disk               connected   configured unknown
c0::rmt/0            tape               connected   configured unknown
c1                   scsi-bus           connected   configured unknown
c1::dsk/c1t3d0       disk               connected   configured unknown
c1::dsk/c1t4d0       disk               connected   configured unknown
```

3. Disconnect the SCSI controller.

```
# cfgadm -c disconnect c1
WARNING: Disconnecting critical partitions may cause system hang.
Continue (yes/no)? y
```



Caution – This command suspends all I/O activity on the SCSI bus until the `cfgadm -c connect` command is used. The `cfgadm` command does some basic checking to prevent critical partitions from being disconnected, but it cannot detect all cases. Inappropriate use of this command can result in a system hang and could require a system reboot.

4. Verify that the SCSI bus is disconnected.

```
# cfgadm -al
Ap_Id                Type                Receptacle  Occupant  Condition
c0                   scsi-bus           connected   configured unknown
c0::dsk/c0t0d0       disk               connected   configured unknown
c0::rmt/0            tape               connected   configured unknown
c1                   unavailable         disconnected  configured unknown
c1::dsk/c1t10d0      unavailable         disconnected  configured unknown
c1::dsk/c1t4d0       unavailable         disconnected  configured unknown
```

The controller and all the devices that are attached to it are disconnected from the system.

▼ SPARC: How to Connect a SCSI Controller

The following procedure uses SCSI controller `c1` as an example of connecting a SCSI controller.

1. Become superuser.
2. Verify that the device is disconnected before you connect it.

```
# cfgadm -al
Ap_Id          Type          Receptacle  Occupant    Condition
c0             scsi-bus     connected   configured  unknown
c0::disk/c0t0d0  disk        connected   configured  unknown
c0::rmt/0       tape         connected   configured  unknown
c1             unavailable  disconnected  configured  unknown
c1::disk/c1t10d0  unavailable  disconnected  configured  unknown
c1::disk/c1t4d0  unavailable  disconnected  configured  unknown
```

3. Connect the SCSI controller.

```
# cfgadm -c connect c1
```

4. Verify that the SCSI controller is connected.

```
# cfgadm -al
Ap_Id          Type          Receptacle  Occupant    Condition
c0             scsi-bus     connected   configured  unknown
c0::disk/c0t0d0  disk        connected   configured  unknown
c0::rmt/0       tape         connected   configured  unknown
c1             scsi-bus     connected   configured  unknown
c1::disk/c1t3d0  disk        connected   configured  unknown
c1::disk/c1t4d0  disk        connected   configured  unknown
```

▼ SPARC: How to Add a SCSI Device to a SCSI Bus

SCSI controller `c1` provides an example of how to add a SCSI device to a SCSI bus.

Note – When you add devices, you specify the `Ap_Id` of the SCSI HBA (controller) to which the device is attached, not the `Ap_Id` of the device itself.

1. Become superuser.
2. Identify the current SCSI configuration.

```
# cfgadm -al
Ap_Id          Type          Receptacle  Occupant    Condition
c0             scsi-bus     connected   configured  unknown
c0::disk/c0t0d0  disk        connected   configured  unknown
c0::rmt/0       tape         connected   configured  unknown
```

```

c1                scsi-bus      connected    configured  unknown
c1::dsk/c1t3d0    disk          connected    configured  unknown

```

3. Add the SCSI device to the SCSI bus.

```

# cfgadm -x insert_device c1
Adding device to SCSI HBA: /devices/sbus@1f,0/SUNW,fas@1,8800000
This operation will suspend activity on SCSI bus: c1

```

a. Type y at the Continue (yes/no) ? prompt to proceed.

```

Continue (yes/no)? y
SCSI bus quiesced successfully.
It is now safe to proceed with hotplug operation.
I/O activity on the SCSI bus is suspended while the hot-plug operation is in
progress.

```

b. Connect the device and then power it on.

c. Type y at the Enter y if operation is complete or n to abort (yes/no) ? prompt.

```

Enter y if operation is complete or n to abort (yes/no)? y

```

4. Verify that the device has been added.

```

# cfgadm -al
Ap_Id                Type          Receptacle  Occupant    Condition
c0                   scsi-bus      connected    configured  unknown
c0::dsk/c0t0d0       disk          connected    configured  unknown
c0::rmt/0            tape          connected    configured  unknown
c1                   scsi-bus      connected    configured  unknown
c1::dsk/c1t3d0       disk          connected    configured  unknown
c1::dsk/c1t4d0       disk          connected    configured  unknown

```

A new disk has been added to controller c1.

▼ SPARC: How to Replace an Identical Device on a SCSI Controller

The following procedure uses SCSI disk c1t4d0 as an example of replacing an identical device on a SCSI controller.

1. Become superuser.

2. Identify the current SCSI configuration.

```

# cfgadm -al
Ap_Id                Type          Receptacle  Occupant    Condition
c0                   scsi-bus      connected    configured  unknown
c0::dsk/c0t0d0       disk          connected    configured  unknown
c0::rmt/0            tape          connected    configured  unknown

```

c1	scsi-bus	connected	configured	unknown
c1::dsk/c1t3d0	disk	connected	configured	unknown
c1::dsk/c1t4d0	disk	connected	configured	unknown

3. Replace a device on the SCSI bus with another device of the same type.

```
# cfgadm -x replace_device c1::dsk/c1t4d0
Replacing SCSI device: /devices/sbus@1f,0/SUNW,fas@1,8800000/sd@4,0
This operation will suspend activity on SCSI bus: c1
```

a. Type **y** at the **Continue (yes/no) ?** prompt to proceed.

I/O activity on the SCSI bus is suspended while the hot-plug operation is in progress.

```
Continue (yes/no)? y
SCSI bus quiesced successfully.
It is now safe to proceed with hotplug operation.
```

b. Power off the device to be removed and remove it.

c. Add the replacement device. Then, power it on.

The replacement device should be of the same type and at the same address (target and lun) as the device to be removed

d. Type **y** at the **Enter y if operation is complete or n to abort (yes/no) ?** prompt.

```
Enter y if operation is complete or n to abort (yes/no)? y
```

4. Verify that the device has been replaced.

```
# cfgadm -al
Ap_Id          Type          Receptacle  Occupant    Condition
c0             scsi-bus     connected   configured  unknown
c0::dsk/c0t0d0 disk          connected   configured  unknown
c0::rmt/0      tape         connected   configured  unknown
c1             scsi-bus     connected   configured  unknown
c1::dsk/c1t3d0 disk          connected   configured  unknown
c1::dsk/c1t4d0 disk          connected   configured  unknown
```

▼ SPARC: How to Remove a SCSI Device

The following procedure uses SCSI disk c1t4d0 as an example of removing a device on a SCSI controller.

1. Become superuser.

2. Identify the current SCSI configuration.

```
# cfgadm -al
Ap_Id          Type          Receptacle  Occupant    Condition
c0             scsi-bus     connected   configured  unknown
```



```

c0::dsk/c0t0d0      disk          connected    configured   unknown
c0::rmt/0           tape          connected    configured   unknown
c1                  scsi-bus     connected    configured   unknown
c1::dsk/c1t3d0     disk          connected    configured   unknown
c1::dsk/c1t4d0     disk          connected    configured   unknown

```

3. Remove the SCSI device from the system.

```

# cfgadm -x remove_device c1::dsk/c1t4d0
Removing SCSI device: /devices/sbus@1f,0/SUNW,fas@1,8800000/sd@4,0
This operation will suspend activity on SCSI bus: c1

```

a. Type y at the Continue (yes/no) ? prompt to proceed.

```

Continue (yes/no)? y
SCSI bus quiesced successfully.
It is now safe to proceed with hotplug operation.
I/O activity on the SCSI bus is suspended while the hot-plug operation is in
progress.

```

b. Power off the device to be removed and remove it.

c. Type y at the Enter y if operation is complete or n to abort (yes/no) ? prompt.

```

Enter y if operation is complete or n to abort (yes/no)? y

```

4. Verify that the device has been removed from the system.

```

# cfgadm -al
Ap_Id          Type          Receptacle  Occupant    Condition
c0             scsi-bus     connected   configured   unknown
c0::dsk/c0t0d0 disk          connected   configured   unknown
c0::rmt/0      tape          connected   configured   unknown
c1             scsi-bus     connected   configured   unknown
c1::dsk/c1t3d0 disk          connected   configured   unknown

```

SPARC: Troubleshooting SCSI Configuration Problems

This section provides error messages and possible solutions for troubleshooting SCSI configuration problems. For more information on troubleshooting SCSI configuration problems, see `cfgadm(1M)`.

Error Message

```

cfgadm: Component system is busy, try again: failed to offline:
  device path
  Resource          Information
-----
/dev/dsk/c1t0d0s0  mounted filesystem "/file-system"

```

Cause

You attempted to remove or replace a device with a mounted file system.

Solution

Unmount the file system that is listed in the error message and retry the `cfgadm` operation.

If you use the `cfgadm` command to remove a system resource, such as a swap device or a dedicated dump device, an error messages similar to the following is displayed if the system resource is still active.

Error Message

```
cfgadm: Component system is busy, try again: failed to offline:
  device path
    Resource          Information
  -----
  /dev/dsk/device-name  swap area
```

Cause

You attempted to remove or replace one or more configured swap areas.

Solution

Unconfigure the swap areas on the device that is specified and retry the `cfgadm` operation.

Error Message

```
cfgadm: Component system is busy, try again: failed to offline:
  device path
    Resource          Information
  -----
  /dev/dsk/device-name  dump device (swap)
```

Cause

You attempted to remove or replace a dump device that is configured on a swap area.

Solution

Unconfigure the dump device that is configured on the swap area and retry the `cfgadm` operation.

Error Message

```
cfgadm: Component system is busy, try again: failed to offline:
  device path
    Resource          Information
  -----
  /dev/dsk/device-name  dump device (dedicated)
```

Cause

You attempted to remove or replace a dedicated dump device.

Solution

Unconfigure the dedicate dump device and retry the `cfgadm` operation.

▼ How to Resolve a Failed SCSI Unconfigure Operation

Use this procedure if one or more target devices are busy and the SCSI unconfigure operation fails. Otherwise, future dynamic reconfiguration operations on this controller and target devices will fail with a `dr in progress` message.

1. **Become superuser, if not done already.**
2. **Type the following command to reconfigure the controller.**

```
# cfgadm -c configure device-name
```

PCI Hot-Plugging With the `cfgadm` Command (Task Map)

Task	Description	For Instructions
1. Display PCI Slot Configuration Information	Display the status of PCI hot-pluggable devices and slots on the system.	"x86: How to Display PCI Slot Configuration Information" on page 388
2. Remove a PCI adapter card	Unconfigure the card, disconnect power from the slot, and remove the card from the system.	"x86: How to Remove a PCI Adapter Card" on page 389
3. Add a PCI adapter card	Insert the adapter card into a hot-pluggable slot, connect power to the slot, and configure the card.	"x86: How to Add a PCI Adapter Card" on page 389
4. Troubleshooting PCI configuration problems	Identify error message and possible solutions to resolve PCI configuration problems.	"x86: Troubleshooting PCI Configuration Problems" on page 390

x86: PCI Hot-Plugging With the `cfgadm` Command

This section provides step-by-step instructions for hot-plugging PCI adapter cards on x86 based systems.

In the examples, only PCI attachment points are listed, for brevity. The attachment points that are displayed on your system depend on your system configuration.

▼ x86: How to Display PCI Slot Configuration Information

The `cfgadmin` command displays the status of PCI hot-pluggable devices and slots on a system. For more information, see `cfgadm(1M)`.

1. **Become superuser.**
2. **Display PCI slot configuration information.**

```
# cfgadm
Ap_Id                Type                Receptacle  Occupant  Condition
pci1:hpc0_slot0     unknown            empty       unconfigured unknown
pci1:hpc0_slot1     unknown            empty       unconfigured unknown
pci1:hpc0_slot2     unknown            empty       unconfigured unknown
pci1:hpc0_slot3     ethernet/hp        connected   configured ok
pci1:hpc0_slot4     unknown            empty       unconfigured unknown
```

Display specific PCI device information.

```
# cfgadm -s "cols=ap_id:type:info" pci
Ap_Id                Type                Information
pci1:hpc0_slot0     unknown            Slot 7
pci1:hpc0_slot1     unknown            Slot 8
pci1:hpc0_slot2     unknown            Slot 9
pci1:hpc0_slot3     ethernet/hp        Slot 10
pci1:hpc0_slot4     unknown            Slot 11
```

The logical `Ap_Id`, `pci1:hpc0_slot0`, is the logical `Ap_Id` for hot-pluggable slot, Slot 7. The component `hpc0` indicates the hot-pluggable adapter card for this slot, and `pci1` indicates the PCI bus instance. The `Type` field indicates the type of PCI adapter card that is present in the slot.

▼ x86: How to Remove a PCI Adapter Card

1. Become superuser.
2. Determine which slot the PCI adapter card is in.

```
# cfgadm
Ap_Id                Type          Receptacle  Occupant    Condition
pci1:hpc0_slot0     unknown      empty       unconfigured unknown
pci1:hpc0_slot1     unknown      empty       unconfigured unknown
pci1:hpc0_slot2     unknown      empty       unconfigured unknown
pci1:hpc0_slot3     ethernet/hp  connected   configured  ok
pci1:hpc0_slot4     unknown      empty       unconfigured unknown
```

3. Stop the application that has the device open.

For example, if the device is an Ethernet card, use the `ifconfig` command to bring down the interface and unplumb the interface.

4. Unconfigure the device.

```
# cfgadm -c unconfigure pci1:hpc0_slot3
```

5. Confirm that the device has been unconfigured.

```
# cfgadm
Ap_Id                Type          Receptacle  Occupant    Condition
pci1:hpc0_slot0     unknown      empty       unconfigured unknown
pci1:hpc0_slot1     unknown      empty       unconfigured unknown
pci1:hpc0_slot2     unknown      empty       unconfigured unknown
pci1:hpc0_slot3     ethernet/hp  connected   unconfigured unknown
pci1:hpc0_slot4     unknown      empty       unconfigured unknown
```

6. Disconnect the power to the slot.

```
# cfgadm -c disconnect pci1:hpc0_slot3
```

7. Confirm that the device has been disconnected.

```
# cfgadm
Ap_Id                Type          Receptacle  Occupant    Condition
pci1:hpc0_slot0     unknown      empty       unconfigured unknown
pci1:hpc0_slot1     unknown      empty       unconfigured unknown
pci1:hpc0_slot2     unknown      empty       unconfigured unknown
pci1:hpc0_slot3     ethernet/hp  disconnected unconfigured unknown
pci1:hpc0_slot4     unknown      empty       unconfigured unknown
```

8. Open the slot latches and remove the PCI adapter card.

▼ x86: How to Add a PCI Adapter Card

1. Become superuser.
2. Identify the hot-pluggable slot and open latches.

3. Insert the PCI adapter card into a hot-pluggable slot.

4. Determine which slot the PCI adapter card is in once it is inserted. Close the latches.

```
# cfgadm
Ap_Id                Type                Receptacle  Occupant  Condition
pci1:hpc0_slot0     unknown            empty       unconfigured unknown
pci1:hpc0_slot1     unknown            empty       unconfigured unknown
pci1:hpc0_slot2     unknown            empty       unconfigured unknown
pci1:hpc0_slot3     ethernet/hp        disconnected unconfigured unknown
pci1:hpc0_slot4     unknown            empty       unconfigured unknown
```

5. Connect the power to the slot.

```
# cfgadm -c connect pci1:hpc0_slot3
```

6. Confirm that the slot is connected.

```
# cfgadm
Ap_Id                Type                Receptacle  Occupant  Condition
pci1:hpc0_slot0     unknown            empty       unconfigured unknown
pci1:hpc0_slot1     unknown            empty       unconfigured unknown
pci1:hpc0_slot2     unknown            empty       unconfigured unknown
pci1:hpc0_slot3     ethernet/hp        connected   unconfigured unknown
pci1:hpc0_slot4     unknown            empty       unconfigured unknown
```

7. Configure the PCI adapter card.

```
# cfgadm -c configure pci1:hpc0_slot3
```

8. Verify the configuration of the PCI adapter card in the slot.

```
# cfgadm
Ap_Id                Type                Receptacle  Occupant  Condition
pci1:hpc0_slot0     unknown            empty       unconfigured unknown
pci1:hpc0_slot1     unknown            empty       unconfigured unknown
pci1:hpc0_slot2     unknown            empty       unconfigured unknown
pci1:hpc0_slot3     ethernet/hp        connected   configured  unknown
pci1:hpc0_slot4     unknown            empty       unconfigured unknown
```

9. Configure any supporting software if this device is a new device.

For example, if this device is an Ethernet card, use the `ifconfig` command to set up the interface.

x86: Troubleshooting PCI Configuration Problems

Error Message

```
cfgadm: Configuration operation invalid: invalid transition
```

Cause

An invalid transition was attempted.

Solution

Check whether the `cfgadm -c` command was issued appropriately. Use the `cfgadm` command to check the current receptacle and occupant state and to make sure that the `Ap_Id` is correct.

Error Message

```
cfgadm: Attachment point not found
```

Cause

The specified attachment point was not found.

Solution

Check whether the attachment point is correct. Use the `cfgadm` command to display a list of available attachment points. Also check the physical path to see if the attachment point is still there.

Note – In addition to the `cfgadm` command, several other commands are helpful during hot-pluggable operations. The `prtconf` command displays whether Solaris recognizes the hardware. After adding hardware, use the `prtconf` command to verify that the hardware is recognized. After a configure operation, use the `prtconf -D` command to verify that the driver is attached to the newly installed hardware device.

Reconfiguration Coordination Manager (RCM) Script Overview

The Reconfiguration Coordination Manager (RCM) is the framework that manages the dynamic removal of system components. By using RCM, you can register and release system resources in an orderly manner.

You can use the new RCM script feature to write your own scripts to shut down your applications, or to cleanly release the devices from your applications during dynamic reconfiguration. The RCM framework launches a script automatically in response to a reconfiguration request, if the request impacts the resources that are registered by the script.

You can also release resources from applications manually before you could dynamically remove the resource. Or, you could use the `cfgadm` command with the `-f` option to force a reconfiguration operation, but this option might leave your applications in an unknown state. Also, the manual release of resources from applications commonly causes errors.

The RCM script feature simplifies and better controls the dynamic reconfiguration process. By creating an RCM script, you can do the following:

- Automatically release a device when you dynamically remove a device. This process also closes the device if the device is opened by an application.
- Run site-specific tasks when you dynamically remove a device from the system.

What Is an RCM Script?

An RCM script is as follows:

- An executable shell script (Perl, sh, csh, or ksh) or binary program that the RCM daemon runs. Perl is the recommended language.
- A script that runs in its own address space by using the user ID of the script file owner.
- A script that is run by the RCM daemon when you use the `cfgadm` command to dynamically reconfigure a system resource.

What Can an RCM Script Do?

You can use an RCM script to release a device from an application when you dynamically remove a device. If the device is currently open, the RCM script also closes the device.

For example, an RCM script for a tape backup application can inform the tape backup application to close the tape drive or shut down the tape backup application.

How Does the RCM Script Process Work?

You can invoke a script as follows:

```
$ script-name command [args ...]
```

A script performs the following basic steps:

1. Takes the RCM command from command-line arguments.
2. Executes the command.
3. Writes the results to `stdout` as name-value pairs.
4. Exits with the appropriate exit status.

The RCM daemon runs one instance of a script at a time. For example, if a script is running, the RCM daemon does not run the same script until the first script exits.

RCM Script Commands

You must include the following RCM commands in an RCM script:

- `scriptinfo` - Gathers script information
- `register` - Registers interest in resources

- `resourceinfo` - Gathers resource information

You might include some or all of the following RCM commands:

- `queryremove` - Queries whether the resource can be released
- `preremove` - Releases the resource
- `postremove` - Provides post-resource removal notification
- `undoremove` - Undoes the actions done in `preremove`

For a complete description of these RCM commands, see `rcmscript(4)`.

RCM Script Processing Environment

When you dynamically remove a device, the RCM daemon runs the following:

- The script's `register` command to gather the list of resources (device names) that are identified in the script.
- The script's `queryremove/preremove` commands prior to removing the resource if the script's registered resources are affected by the dynamic remove operation.
- The script's `postremove` command if the remove operation succeeds. However, if the remove operation fails, the RCM daemon runs the script's `undoremove` command.

RCM Script Tasks

The following sections describe the RCM script tasks for application developers and system administrators.

Application Developer RCM Script (Task Map)

The following task map describes the tasks for an application developer who is creating an RCM script.

Task	Description	For Instructions
1. Identify resources your application uses	Identify the resources (device names) your application uses that you could potentially dynamically remove.	<code>cfgadm(1M)</code>

Task	Description	For Instructions
2. Identify commands to release the resource	Identify the commands for notifying the application to cleanly release the resource from the application.	Application documentation
3. Identify commands for post-removal of the resource	Include the commands for notifying the application of the resource removal.	rcmscript(4)
4. Identify commands if the resource removal fails	Include the commands for notifying the application of the available resource.	rcmscript(4)
5. Write the RCM script	Write the RCM script based on the information identified in the previous tasks.	"Tape Backup RCM Script Example" on page 397
6. Install the RCM script	Add the script to the appropriate script directory.	"How to Install an RCM Script" on page 395
7. Test the RCM script	Test the script by running the script commands manually and by initiating a dynamic reconfiguration operation.	"How to Test an RCM Script" on page 396

System Administrator RCM Script (Task Map)

The following task map describes the tasks for a system administrator who is creating an RCM script to do site customization.

Task	Description	For Instructions
1. Identify resources to be dynamically removed	Identify the resources (device names) to be potentially removed by using the <code>cfgadm -l</code> command.	cfgadm(1M)
2. Identify applications to be stopped	Identify the commands for stopping the applications cleanly.	Application documentation
3. Identify commands for pre-removal and post-removal of the resource	Identify the actions to be taken before and after the resource is removed.	rcmscript(4)
4. Write the RCM script	Write the RCM script based on the information identified in the previous tasks.	"Tape Backup RCM Script Example" on page 397

Task	Description	For Instructions
5. Install the RCM script	Add the script to the appropriate script directory.	“How to Install an RCM Script” on page 395
6. Test the RCM script	Test the script by running the script commands manually and by initiating a dynamic reconfiguration operation.	“How to Test an RCM Script” on page 396

Naming an RCM Script

A script must be named as *vendor,service* where the following applies:

<i>vendor</i>	Is the stock symbol of the vendor that provides the script, or any distinct name that identifies the vendor.
<i>service</i>	Is the name of the service that the script represents.

Installing or Removing an RCM Script

You must be superuser (root) to install or remove an RCM script. Use this table to determine where you should install your RCM script.

TABLE 28-1 RCM Script Directories

Directory Location	Script Type
<code>/etc/rcm/scripts</code>	Scripts for specific systems
<code>/usr/platform/`uname -i`/lib/rcm/scripts</code>	Scripts for a specific hardware implementation
<code>/usr/platform/`uname -m`/lib/rcm/scripts</code>	Scripts for a specific hardware class
<code>/usr/lib/rcm/scripts</code>	Scripts for any hardware

▼ How to Install an RCM Script

1. **Become superuser.**
2. **Copy the script to the appropriate directory as described in Table 28-1.**

For example:

```
# cp SUNW,sample.pl /usr/lib/rcm/scripts
```

3. Change the user ID and the group ID of the script to the desired values.

```
# chown user:group /usr/lib/rcm/scripts/SUNW,sample.pl
```

4. Send `SIGHUP` to the RCM daemon.

```
# pkill -HUP -x -u root rcm_daemon
```

▼ How to Remove an RCM Script

1. Become superuser.

2. Remove the script from the RCM script directory.

For example:

```
# rm /usr/lib/rcm/scripts/SUNW,sample.pl
```

3. Send `SIGHUP` to the RCM daemon.

```
# pkill -HUP -x -u root rcm_daemon
```

▼ How to Test an RCM Script

1. Set environment variables, such as `RCM_ENV_FORCE`, in the command-line shell before running your script.

For example, in the Korn shell, use the following:

```
$ export RCM_ENV_FORCE=TRUE
```

2. Test the script by running the script commands manually from the command line.

For example:

```
$ script-name scriptinfo
$ script-name register
$ script-name preremove resource-name
$ script-name postremove resource-name
```

3. Make sure each RCM script command in your script prints appropriate output to `stdout`.

4. Install the script in the appropriate script directory.

For more information, see “How to Install an RCM Script” on page 395.

5. Test the script by initiating a dynamic remove operation:

For example, assume your script registers the device, `/dev/dsk/c1t0d0s0`. Try these commands.

```
$ cfgadm -c unconfigure c1::dsk/c1t0d0
$ cfgadm -f -c unconfigure c1::dsk/c1t0d0
```

```
$ cfgadm -c configure c1::dsk/c1t0d0
```



Caution – Make sure that you are familiar with these commands because they can alter the state of the system and can cause system failures.

Tape Backup RCM Script Example

This example illustrates how to use an RCM script for tape backups.

What the Tape Backup RCM Script Does

The tape backup RCM script performs the following steps:

1. Sets up a dispatch table of RCM commands.
2. Calls the dispatch routine that corresponds to the specified RCM command and exits with status 2 for unimplemented RCM commands.
3. Sets up the `scriptinfo` section:

```
rcm_script_func_info=Tape backup appl script for DR
```

4. Registers all tape drives in the system by printing all tape drive device names to `stdout`.

```
rcm_resource_name=/dev/rmt/$f
```

If an error occurs, prints the error information to `stdout`.

```
rcm_failure_reason=$errmsg
```

5. Sets up the resource information for the tape device.

```
rcm_resource_usage_info=Backup Tape Unit Number $unit
```

6. Sets up the `preremove` information by checking if the backup application is using the device. If the backup application is not using the device, the dynamic reconfiguration operation continues. If the backup application is using the device, the script checks `RCM_ENV_FORCE`. If `RCM_ENV_FORCE` is set to `FALSE`, the script denies the dynamic reconfiguration operation and prints the following message:

```
rcm_failure_reason=tape backup in progress pid=...
```

If `RCM_ENV_FORCE` is set to `TRUE`, the backup application is stopped, and the reconfiguration operation proceeds.

Outcomes of the Tape Backup Reconfiguration Scenarios

Here are the various outcomes if you use the `cfgadm` command to remove a tape device without the RCM script.

- If you use the `cfgadm` command and the backup application is not using the tape device, the operation succeeds.
- If you use the `cfgadm` command and the backup application is using the tape device, the operation fails.

Here are the various outcomes if you use the `cfgadm` command to remove a tape device with the RCM script.

- If you use the `cfgadm` command and the backup application is not using the tape device, the operation succeeds.
- If you use the `cfgadm` command without the `-f` option and the backup application is using the tape device, the operation fails with an error message similar to the following:

```
tape backup in progress pid=...
```

- If you use the `cfgadm -f` command and the backup application is using the tape device, the script stops the backup application and the `cfgadm` operation succeeds.

Example—Tape Backup RCM Script

```
#!/usr/bin/perl -w
#
# A sample site customization RCM script.
#
# When RCM_ENV_FORCE is FALSE this script indicates to RCM that it cannot
# release the tape drive when the tape drive is being used for backup.
#
# When RCM_ENV_FORCE is TRUE this script allows DR removing a tape drive
# when the tape drive is being used for backup by killing the tape
# backup application.
#

use strict;

my ($cmd, %dispatch);
$cmd = shift(@ARGV);
# dispatch table for RCM commands
%dispatch = (
    "scriptinfo" => \&do_scriptinfo,
    "register" => \&do_register,
    "resourceinfo" => \&do_resourceinfo,
    "queryremove" => \&do_preremove,
    "preremove" => \&do_preremove
);

if (defined($dispatch{$cmd})) {
    &{$dispatch{$cmd}};
} else {
    exit (2);
}
```

```

sub do_scriptinfo
{
    print "rcm_script_version=1\n";
    print "rcm_script_func_info=Tape backup appl script for DR\n";
    exit (0);
}

sub do_register
{
    my ($dir, $f, $errmsg);

    $dir = opendir(RMT, "/dev/rmt");
    if (!$dir) {
        $errmsg = "Unable to open /dev/rmt directory: $!";
        print "rcm_failure_reason=$errmsg\n";
        exit (1);
    }

    while ($f = readdir(RMT)) {
        # ignore hidden files and multiple names for the same device
        if (($f !~ /\./) && ($f =~ /^[0-9]+$)) {
            print "rcm_resource_name=/dev/rmt/$f\n";
        }
    }

    closedir(RMT);
    exit (0);
}

sub do_resourceinfo
{
    my ($rsrc, $unit);

    $rsrc = shift(@ARGV);
    if ($rsrc =~ /^\/dev\/rmt\/([0-9]+)$/) {
        $unit = $1;
        print "rcm_resource_usage_info=Backup Tape Unit Number $unit\n";
        exit (0);
    } else {
        print "rcm_failure_reason=Unknown tape device!\n";
        exit (1);
    }
}

sub do_preremove
{
    my ($rsrc);

    $rsrc = shift(@ARGV);

    # check if backup application is using this resource
    #if (the backup application is not running on $rsrc) {
        # allow the DR to continue
    #    exit (0);
}

```

```

#)
#
# If RCM_ENV_FORCE is FALSE deny the operation.
# If RCM_ENV_FORCE is TRUE kill the backup application in order
# to allow the DR operation to proceed
#
if ($ENV{RCM_ENV_FORCE} eq 'TRUE') {
    if ($cmd eq 'preremove') {
        # kill the tape backup application
    }
    exit (0);
} else {
    #
    # indicate that the tape drive can not be released
    # since the device is being used for backup by the
    # tape backup application
    #
    print "rcm_failure_reason=tape backup in progress pid=...\n"
;

    exit (3);
}
}

```

Using USB Devices (Overview / Tasks)

This chapter provides an overview of Universal Serial Bus (USB) devices and step-by-step instructions for using USB devices in the Solaris environment.

For information on the procedures associated with using USB devices, see the following:

- “Using USB Mass Storage Devices (Task Map)” on page 409
- “Using USB Audio Devices (Task Map)” on page 417
- “Hot-Plugging USB Devices With the `cfgadm` Command (Task Map)” on page 423

This is a list of the overview information in this chapter.

- “Overview of USB Devices” on page 401
- “About USB in the Solaris Environment” on page 406
- “Using USB Mass Storage Devices” on page 409
- “Hot-Plugging USB Devices” on page 410
- “Using USB Audio Devices” on page 417
- “Troubleshooting USB Audio Device Problems” on page 422
- “Hot-Plugging USB Devices With the `cfgadm` Command” on page 424

For general information about dynamic reconfiguration and hot-plugging, see Chapter 28.

For information on configuring USB printers, see “What’s New in Printing?” in *System Administration Guide: Advanced Administration*.

Overview of USB Devices

Universal Serial Bus (USB) was developed by the PC industry to provide a low-cost solution for attaching peripheral devices, such as keyboards, mouse devices, and printers, to a system.

USB connectors are designed to fit only one type of cable, one way. The primary design motivation for USB was to alleviate the need for multiple connector types for different devices. This design reduces the clutter on the back panel of a system.

Devices connect to USB ports on external USB hubs, or on a root hub that is located on the computer itself. Since hubs have several ports, several branches of a device tree can stem from a hub.

Additional advantages of using USB devices are as follows:

- USB devices are hot-pluggable. For more information, see “Hot-Plugging USB Devices” on page 410.
- USB 1.1 devices are supported in the Solaris 9 environment.
- Supports a maximum of 126 devices per host controller in the Solaris environment.
- Supports a maximum of 12 Mbit/sec data transfer.
- Supports low-speed (1.5 Mbit/sec) and full-speed (12 Mbit/sec).
- Solaris Ready USB PCI controllers are available. For more information, see <http://www.sun.com/io>.
- The bus can be easily extended by adding low-cost external hubs. Hubs can be connected to hubs to form a tree topology.

Sun Microsystems platform provides support for USB devices includes the following:

- SPARC based systems with OHCI host controllers that support USB 1.1 provide low- and full-speed devices:
 - Sun Blade™ systems that run the Solaris 8 or 9 release.
 - Netra™ X1/T1 and some Sun Fire™ systems that run the Solaris 9 release.
- SPARC based systems provide support for low- and full-speed support for USB 1.1 devices:

Any PCI-based sun4u system including those listed above, that run the Solaris 8 or 9 release.
- x86 based systems with OHCI and UHCI controllers that run the Solaris 8 or 9 x86 Platform Editions provide USB 1.1 support.
- x86 based systems with OHCI host controllers that run the Solaris 8 or 9 x86 Platform Editions provide USB 1.1 support.

This table lists specific USB devices that are supported in the Solaris environment.

USB Devices	Systems Supported
HID control on audio devices	SPARC based and x86 based systems.
Hubs	SPARC based and x86 based systems.
Keyboards and mouse devices	SPARC based and x86 based systems.

USB Devices	Systems Supported
Mass storage devices	SPARC based and x86 based systems. Supported configurations include only one keyboard and mouse. These devices must be connected to an on-board USB host controller.
Printers	SPARC based and x86 based systems.
Speakers and microphones	SPARC based and x86 based systems.

Commonly Used USB Acronyms

The following table describes the USB acronyms that are used in the Solaris environment. For a complete description of USB components and acronyms, go to <http://www.usb.org>.

Acronym	Definition
USB	Universal Serial Bus
USBA	Universal Serial Bus Architecture (Solaris)
USBAI	USBA Client Driver Interface (Solaris)
HCD	USB host controller driver
EHCI	Enhanced Open Controller Interface
OHCI	Open Host Controller Interface
UHCI	Universal Host Controller Interface

USB Bus Description

The USB specification is openly available and free of royalties. The specification defines the electrical and mechanical interfaces of the bus and the connectors.

USB employs a topology in which hubs provide attachment points for USB devices. The host controller contains the root hub, which is the origin of all USB ports in the system. For more information about hubs, see “USB Host Controller and Root Hub” on page 407.

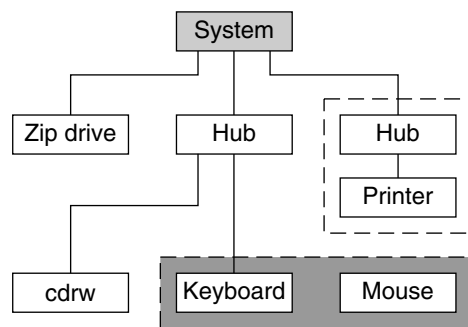

- USB Host Controller and Root Hub
- Compound Device
- Composite Device

FIGURE 29-1 USB Physical Device Hierarchy

Figure 29-1 shows a system with three active USB ports. The first USB port connects a Zip drive. The second USB port connects an external hub, which in turn, connects a cdrw device, and a composite keyboard and mouse device. Being a *composite device*, this keyboard contains a USB controller, which operates both the keyboard and an attached mouse. The keyboard and the mouse share a common USB bus address because they are directed by the same USB controller.

Figure 29-1 also shows an example of a hub and a printer as a *compound device*. The hub is an external hub that is enclosed in the same casing as the printer. The printer is permanently connected to the hub. However, the hub and printer have separate USB bus addresses. The same diagram shows an example of a *composite device*.

The device tree path name for some of the devices that are displayed in Figure 29-1 are listed in this table.

Zip drive	/pci@1f,4000/usb@5/storage@1
Keyboard	/pci@1f,4000/usb@5/hub@2/device@1/keyboard@0
Mouse	/pci@1f,4000/usb@5/hub@2/device@1/mouse@1
cdrw device	/pci@1f,4000/usb@5/hub@2/storage@3
Printer	/pci@1f,4000/usb@5/hub@3/printer@1

USB Devices and Drivers

USB devices are divided into device classes. Each device class has a corresponding driver. Devices within a class are managed by the same device driver. However, the USB specification also allows for vendor-specific devices that are not part of a specific class. Devices with similar attributes and services are grouped.

The Human Interface Device (HID) class contains devices that are user-controlled such as keyboards, mouse devices, and joysticks. The Communication Device class contains devices that connect to a telephone, such as modems or an ISDN interface. Other device classes include the Audio, Monitor, Printer, and Storage Device classes. Each USB device contains descriptors that reflect the class of the device. A device class specifies how its members should behave in configuration and data transfer. You can obtain additional class information from <http://www.usb.org>.

Solaris USB Architecture (USBA)

USB devices are represented as two levels of device tree nodes. A device node represents the entire USB *device*. One or more child *interface* nodes represent the individual USB interfaces on the device. For special cases, the device nodes and interface nodes are *combined* into a single combined node.

Driver binding is achieved by using the compatible name properties. For more information, refer to 3.2.2.1 of the IEEE 1275 USB binding and *Writing Device Drivers*. A driver can either bind to the entire device and control all the interfaces, or can bind to just one interface. If no vendor or class driver claims the entire device, a generic USB multi-interface driver is bound to the device-level node. This driver attempts to bind drivers to each interface by using compatible names properties, as defined in section 3.3.2.1 of the IEEE 1275 binding specification.

The Solaris USB Architecture (USBA) adheres to the USB 1.1 specification plus Solaris driver requirements. The USBA model is similar to Sun Common SCSI Architecture (SCSA). The USBA is a thin layer that provides a generic USB transport-layer abstraction to the client driver.

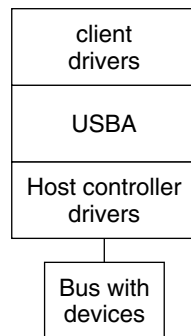

FIGURE 29-2 Solaris USB Architecture (USBA)

About USB in the Solaris Environment

This section describes information you should know about USB in the Solaris environment.

USB Keyboards and Mouse Devices

Only Sun USB keyboards and mouse devices are supported. System configurations with multiple USB keyboards and mouse devices might work, but are not supported in the Solaris environment. See the following items for details.

- A USB keyboard and mouse can be connected anywhere on the bus and can be configured as the console keyboard and mouse. Booting the system is slower if the keyboard and mouse are not on the root hub.
- Do not move the console keyboard and mouse *during* a reboot or at the `ok` prompt. You can move the console keyboard and mouse to another hub at any time *after* a system reboot. After you plug in a keyboard and mouse, they are fully functional again.
- **SPARC** – The power key on a USB keyboard behaves differently than the power key on the Sun type 5 keyboard. On a USB keyboard, you can suspend or shut down the system by using the SUSPEND/SHUTDOWN key, but you cannot use that key to power up the system.
- The keys just to the left of the keypad do not function on third-party USB keyboards.
- Multiple keyboards are not supported:

- Multiple keyboards enumerate and are usable, but they are not plumbed as console keyboards.
- The first keyboard that is probed at boot time becomes the console keyboard. The result of this probing might cause confusion if multiple keyboards are plugged in at boot time.
- If you unplug the console keyboard, the next available USB keyboard does not become the console keyboard. The next hot-plugged keyboard becomes the console keyboard.
- Multiple mouse devices are not supported:
 - Multiple mouse devices enumerate and are usable, but they are not plumbed as console mouse devices.
 - The first mouse that is probed at boot time becomes the console mouse. The result of this probing might cause confusion if you have multiple mouse devices plugged in at boot time.
 - If you unplug the console mouse, the next available USB mouse does not become the console mouse. The next hot-plugged mouse becomes the console mouse.
- If you have a third-party composite keyboard with a PS/2 mouse, and the composite keyboard/mouse is the first one to be probed, it becomes the console keyboard/mouse even if the PS/2 mouse is not plugged in. Thus, another USB mouse plugged into the system cannot work because it is not configured as the console mouse.
- Only two-button and three-button mouse devices are supported. A wheel-on-wheel mouse acts like a plain-button mouse. A mouse with more than three buttons functions like a three-button mouse.

USB Host Controller and Root Hub

A USB hub is responsible for the following:

- Monitoring the insertion or removal of a device on its ports
- Power-managing individual devices on its ports
- Controlling power to its ports

The USB host controller has an embedded hub called the *root hub*. The ports that are visible at the system's back panel are the ports of the root hub. The USB host controller is responsible for the following:

- Directing the USB bus. Individual devices cannot arbitrate for the bus.
- Polling the devices by using a polling interval that is determined by the device. The device is assumed to have sufficient buffering to account for the time between the polls.
- Sending data between the USB host controller and its attached devices. Peer-to-peer communication is not supported.

USB Hub Devices

- Do not cascade hubs beyond four levels on either SPARC based or x86 based systems. On SPARC systems, the OpenBoot™ PROM cannot reliably probe beyond four levels of devices.
- Do not plug a bus-powered hub into another bus-powered hub in a cascading style. A bus-powered hub does not have its own power supply.
- Do not connect a device that requires a large amount of power to a bus-powered hub. These devices might not work well on bus-powered hubs or might drain the hub of power for other devices. An example of such a device is a USB diskette device.

SPARC: USB Power Management

Suspending and resuming USB devices are fully supported on SPARC systems. However, do not suspend a device that is busy and never remove a device when the system is powered off under a suspend shutdown.

If the SPARC based system has power management enabled, the USB framework makes a best effort to power-manage all devices. Power-managing a USB device means that the hub driver suspends the port to which the device is connected. Devices that support *remote wake up* can notify the system to wake up everything in the device's path, so that the device can be used. The host system could also wake up the device if an application sends an I/O to the device.

All HID (keyboard, mouse, speakers, microphones), hub, and storage devices are power-managed by default if they support remote wake up capability. A USB printer is power-managed only between two print jobs.

When power management is running to reduce power consumption, USB leaf devices are powered down first. When all devices that are connected to this hub's ports are powered down, the hub is powered down after some delay. To achieve the most efficient power management, do not cascade many hubs.

Guidelines for USB Cables

Keep the following guidelines in mind when connecting USB cables:

- Always use USB 1.0 compliant, fully rated (12 Mbit/sec) 20/28 AWG cables for connecting USB devices. Use bus-powered hubs for low-speed devices only. Always use fully rated (12 Mbit/sec) 20/28 AWG cables for connecting USB devices.
- Maximum cable length that is supported is 5 meters.
- Do not use cable extenders. For best results, use a self-powered hub to extend cable length.

For more information, go to
<http://www.usb.org/channel/training/warning>.

Using USB Mass Storage Devices (Task Map)

Task	Description	For Instructions
1. Add a USB mass storage device	Add a USB mass storage device with <code>vold</code> running.	"How to Add a USB Mass Storage Device With <code>vold</code> Running" on page 411
	Add a USB mass storage device without <code>vold</code> running.	"How to Add a USB Mass Storage Device Without <code>vold</code> Running" on page 411
2. Remove a USB mass storage device	Remove a USB mass storage device with <code>vold</code> running.	"How to Remove a USB Mass Storage Device With <code>vold</code> Running" on page 412
	Remove a USB mass storage device without <code>vold</code> running.	"How to Remove a USB Mass Storage Device Without <code>vold</code> Running" on page 412
3. Mount a USB mass storage device	Mount a USB mass storage device with <code>vold</code> running.	"How to Mount or Unmount a USB Mass Storage Device With <code>vold</code> Running" on page 414
	Mount a USB mass storage device without <code>vold</code> running.	"How to Mount or Unmount a USB Mass Storage Device Without <code>vold</code> Running" on page 415
4. Add a USB camera	Add a USB camera to access digital images.	"How to Add a USB Camera" on page 415

Using USB Mass Storage Devices

Starting in the Solaris 9 release, removable mass storage devices such as USB CD-RWs, hard disks, DVDs, digital cameras, Zip, Peerless, SmartMedia, CompactFlash, ORB, and USB diskettes are supported.

For a complete list of USB devices that are supported in the Solaris environment, see http://www.sun.com/io_technologies/storagesolutions.html.

These devices can be managed with or without volume management. For information on managing devices with volume management, see `vold(1M)`.

Using Non-Compliant USB Mass Storage Devices

Some devices might be supported by the USB mass storage driver even though they do not identify themselves as compliant with the USB mass storage class or identify themselves incorrectly. The `scsa2usb.conf` file contains an attribute-override-list that lists the vendor ID, product ID, and revision for matching mass storage devices, as well as fields for overriding the default device attributes. The entries in this list are commented out by default, and can be copied and uncommented to enable support of particular devices.

If you connect a USB mass storage device to a system running the Solaris release and the system is unable to use it, you can check the `/kernel/drv/scsa2usb.conf` file to see if there is a matching, commented entry for this device. Follow the information given in the `scsa2usb.conf` file to see if a particular device can be supported by using the override information. For a listing of recommended USB mass storage devices, go to <http://www.sun.com/io>.

For more information, see `scsa2usb(7D)`.

Hot-Plugging USB Devices

Hot-plugging a device means the device is added or removed without shutting down the operating system or powering off the system. All USB devices are hot-pluggable.

When you hot-plug a USB device, the device is immediately seen in the system's device hierarchy, as displayed in the `prtconf` command output. When you remove a USB device, the device is removed from the system's device hierarchy, unless the device is in use.

If the USB device is in use when it is removed, the hot-plug behavior is a little different. If a device is in use when it is unplugged, the device node remains, but the driver controlling this device stops all activity on the device. Any new I/O activity issued to this device is returned with an error.

In this situation, the system prompts you to plug in the original device. If the device is no longer available, stop the applications. After a few seconds, the port will become available again.

Note – Data integrity might be impaired if you remove an active or open device. Always close the device before removing, except the console keyboard and mouse, which can be moved while active.

▼ How to Add a USB Mass Storage Device With `vold` Running

This procedure describes how to add a USB device with `vold` running.

For more information on volume management device names, see Chapter 17.

1. **Insert the USB mass storage device.**
2. **Instruct `vold` to scan for new devices.**

```
# touch /etc/vold.conf
```

3. **Restart `vold`.**

```
# pkill -HUP vold
```

4. **Verify that the device has been added.**

```
$ ls device-alias
```

▼ How to Add a USB Mass Storage Device Without `vold` Running

This procedure describes how to add a USB device without `vold` running.

1. **Add a USB device into the USB port.**
2. **Verify that the USB device has been added.**

Locate the USB disk device links, which may be among device links of non-USB storage devices, as follows:

```
$ cd /dev/rdisk
$ ls -l c*0 | grep usb
lrwxrwxrwx 1 root root 67 Apr 30 15:12 c1t0d0s0 ->
  ../../devices/pci@1f,0/pci@5/pci@0/usb@8,2/storage@1/disk@0,0:a,raw
```

▼ How to Remove a USB Mass Storage Device With `vold` Running

The following procedure uses a Zip drive as an example of removing a USB device with `vold` running.

1. **Unmount the device.**

```
$ volrmount -e zip0
```

2. **Stop any active applications that are using the device.**

3. **Unmount the device.**

```
$ volrmount -e zip0
```

4. **Eject the device.**

```
$ eject zip0
```

5. **Become superuser and stop `vold`.**

```
# /etc/init.d/volmgt stop
```

6. **Remove the USB mass storage device.**

7. **Start `vold`.**

```
# /etc/init.d/volmgt start
```

▼ How to Remove a USB Mass Storage Device Without `vold` Running

This procedure describes how to remove a USB device without `vold` running.

1. **Become superuser.**

2. **Stop any active applications that are using the device.**

3. **Remove the USB device.**

- a. **Unmount the device.**

```
# umount /mount-point
```

- b. **Remove the device.**

Mounting USB Mass Storage Devices With or Without `vold` Running

If you are running Solaris Common Desktop Environment (CDE), the USB removable mass storage devices are managed by the Removable Media Manager component of the CDE File Manager. For more information on the CDE File Manager, see `dtfile(1)`.

Note – You must include the `/usr/dt/man` directory in your `MANPATH` variable to display the man pages that are listed in this section. You must also have the `/usr/dt/bin` directory in your path and have CDE running to use these commands, or have a `DISPLAY` variable set to use these commands remotely.

The following table identifies the commands that Removable Media Manager uses to manage storage devices from the CDE environment.

Command	Man Page	Task
<code>sdtmedia_format</code>	<code>sdtmedia_format(1)</code>	Format and label a device
<code>sdtmedia_prop</code>	<code>sdtmedia_prop(1)</code>	Display properties of a device
<code>sdtmedia_prot</code>	<code>sdtmedia_prot(1)</code>	Change device protection
<code>sdtmedia_slice</code>	<code>sdtmedia_slice(1)</code>	Create or modify slices on a device

After the USB device is formatted, it is usually mounted under the `/rmdisk/label` directory. For more information on configuring removable storage devices, see `rmmount.conf(4)` or `vold.conf(4)`.

The device nodes are created under the `/vol/dev` directory. For more information, see `scsa2usb(7D)`.

You can use USB mass storage devices without the volume manager (`vold`) running. Here are two ways to avoid using the volume manager.

- Stop `vold` by issuing this command:

```
# /etc/init.d/volmgt stop
```
- Keep `vold` running, but do not register the USB mass storage devices with `vold`. Remove volume manager registration of USB mass storage devices by commenting the following line in the `/etc/vold.conf` file, like this:

```
# use rmdisk drive /dev/rdisk/c*s2 dev_rmdisk.so rmdisk%d
```

After this line is commented, restart `vold`.

```
# /etc/init.d/volmgt start
```



Caution – If you comment out this line and other SCSI or ATAPI Zip or Jaz removable devices are in the system, `vold` registration for these devices would be disabled as well.

For more information, see `vold.conf(4)`.

The following procedures describe how to manage USB mass storage devices without `vold` running. The device nodes are created under the `/dev/rdisk` directory for character devices and under the `/dev/dsk` directory for block devices. For more information, see `scsa2usb(7D)`.

How to Mount or Unmount a USB Mass Storage Device With `vold` Running

1. **Display device aliases for all removable mass storage devices, including USB mass storage devices.**

```
$ eject -n
.
.
.
rmdisk0 -> /vol/dev/rdsk/c4t0d0/clik40      (Generic USB storage)
cdrom0 -> /vol/dev/rdsk/c0t6d0/audio_cd    (Generic CD device)
zip1 -> /vol/dev/rdsk/c2t0d0/fat32        (USB Zip device)
zip0 -> /vol/dev/rdsk/c1t0d0/zip100       (USB Zip device)
jaz0 -> /vol/dev/rdsk/c3t0d0/jaz1gb       (USB Jaz device)
```

2. **Mount a USB mass storage device by using the device aliases listed previously.**

```
$ volrmount -i device-alias
```

This example shows how to mount a USB Zip drive (`/rmdisk/zip0`).

```
$ volrmount -i zip0
```

3. **Unmount a USB mass storage device.**

```
$ volrmount -e device-alias
```

This example shows how to unmount a USB Zip drive (`/rmdisk/zip0`).

```
$ volrmount -e zip0
```

4. **Eject a USB device from a generic USB drive.**

```
$ eject device-alias
```

For example:

```
$ eject rmdisk0
```

Note – The `eject` command also unmounts the device if the device is not unmounted already. The command also terminates any active applications that access the device.

How to Mount or Unmount a USB Mass Storage Device Without `void` Running

1. **Become superuser.**
2. **Mount a USB mass storage device.**

```
# mount -F fs-type /dev/dsk/cntndnsn /mount-point
```

This command might fail if the device is read-only. Use the following command for CD-ROM devices.

```
# mount -F fs-type -o ro /dev/dsk/cntndnsn /mount-point
```

For example:

```
# mount -F hfs -o ro /dev/dsk/c0t6d0s2 /mnt
```

3. **Unmount a USB mass storage device.**

```
# umount /mount-point
```

4. **Eject the device.**

```
# eject /dev/[r]dsk/cntndnsn
```

▼ How to Add a USB Camera

Use this procedure to add a USB camera.

1. **Become superuser.**
2. **Plug in and turn on the USB camera.**

The system creates a logical device for the camera. After the camera is plugged in, output is written to the `/var/adm/messages` file to acknowledge the device's connection. The camera is seen as a storage device to the system.

3. **Examine the output that is written to the `/var/adm/messages` file.**

Examining this output enables you to determine which logical device was created so that you can then use that device to access your images. The output will look similar to the following:

```
# more /var/adm/messages
Jul 15 09:53:35 buffy usba: [ID 349649 kern.info] OLYMPUS, C-3040ZOOM,
000153719068
Jul 15 09:53:35 buffy genunix: [ID 936769 kern.info] scsa2usb1 is
/pci@0,0/pci925,1234@7,2/storage@2
Jul 15 09:53:36 buffy scsi: [ID 193665 kern.info] sd3 at scsa2usb1:
target 0 lun 0
```

4. Mount the USB camera file system.

The camera's file system is most likely a PCFS file system. In order to mount the file system on the device created, the slice that represents the disk must be specified. The slice is normally `s0` for a SPARC system, and `p0` for an x86 system. For example, to mount the file system on an x86 system, execute the following command:

```
# mount -F pcfs /dev/dsk/c3t0d0p0:c /mnt
```

To mount the file system on a SPARC system, execute the following command:

```
# mount -F pcfs /dev/dsk/c3t0d0s0:c /mnt
```

For information on mounting file systems, see Chapter 40.

For information on mounting different PCFS file systems, see `mount_pcfs(1M)`.

5. Verify that the image files are available.

For example:

```
# ls /mnt/DCIM/100OLYMP/
P7220001.JPG* P7220003.JPG* P7220005.JPG*
P7220002.JPG* P7220004.JPG* P7220006.JPG*
```

6. View and manipulate the image files created by the USB camera.

```
# /usr/dt/bin/sdtimage P7220001.JPG &
```

7. Unmount the file system before disconnecting the camera.

For example:

```
# umount /mnt
```

8. Turn off and disconnect the camera.

Using USB Audio Devices (Task Map)

Task	Description	For Instructions
1. Add USB audio devices	Add a USB microphone and speakers.	"How to Add USB Audio Devices" on page 418
2. Identify your system's primary audio device	Identify which audio device is your primary audio device.	"How to Identify Your System's Primary Audio Device" on page 419
3. Change the primary USB audio device	You might want to make one particular audio device the primary audio device if you remove or change your USB audio devices.	"How to Change the Primary USB Audio Device" on page 420
4. Remove unused USB audio device links	If you remove a USB audio device while the system is powered off, the <code>/dev/audio</code> device might be pointing to a <code>/dev/sound/*</code> device that doesn't exist.	"How to Remove Unused USB Audio Device Links" on page 422
5. Troubleshoot USB audio device problems	You might have to power cycle USB speakers.	"Solving USB Speaker Problems" on page 423

Using USB Audio Devices

This Solaris release provides USB audio support which is implemented by a pair of cooperating drivers, `usb_ac` and `usb_as`. The audio control driver, `usb_ac`, is a USB A (Solaris USB Architecture) compliant client driver that provides the controlling interface to user applications. The audio streaming driver, `usb_as`, is provided to process audio data messages during play and record and set sample frequency, precision, and encoding requests from the `usb_ac` driver.

Both drivers comply to the USB audio class 1.0 specification.

Solaris supports external USB audio devices that are play-only or record-only. Onboard USB audio devices are not supported. For supported audio data format information, see `usb_ac(7D)`.

- If the audio device has volume under software control, `usb_ah`, a STREAMS module, is pushed on top of the HID driver for managing this button.

- USB audio devices are supported on SPARC Ultra and x86 platforms that have USB connectors.
- Hot-plugging USB audio devices is supported.
- USB audio devices must support a continuous sample rate of between 8000 and 48000 Hz. Or, the USB audio devices must support a 48000 Hz sample rate to play or record on the Solaris 8 10/01, Solaris 8 2/02, or Solaris 9 release.

The primary audio device is `/dev/audio`. You can verify that `/dev/audio` is pointing to USB audio by using the following command:

```
% mixerctl
Device /dev/audioc1:
  Name      = USB Audio
  Version   = 1.0
  Config    = external
```

Audio mixer for `/dev/audioc1` is enabled

After you connect your USB audio devices, you access them with the `audioplay` and `audiorecord` command through the following files:

```
/dev/sound/N
```

You can select a specific audio device by setting the `AUDIODEV` environment variable or by specifying the `-d` option to the `audioplay` and `audiorecord` commands. However, setting `AUDIODEV` does not work for applications that have `/dev/audio` hardcoded as the audio file.

When you plug in a USB audio device, it automatically becomes the primary audio device, `/dev/audio`, unless `/dev/audio` is in use. For instructions on changing `/dev/audio` from onboard audio to USB audio and vice versa, refer to “How to Change the Primary USB Audio Device” on page 420, and `usb_ac(7D)`.

Hot-Plugging Multiple USB Audio Devices

If a USB audio device is plugged into a system, it becomes the primary audio device, `/dev/audio`. It remains the primary audio device even after the system is rebooted. If additional USB audio devices are plugged in, the last one becomes the primary audio device.

For additional information on troubleshooting USB audio device problems, see `usb_ac(7D)`.

▼ How to Add USB Audio Devices

Use the following procedure to add USB audio devices.

1. **Plug in the USB speakers and microphone.**

The primary audio device, `/dev/audio`, usually points to the onboard audio. After you connect USB audio devices, `/dev/audio` points to the USB audio devices that are identified in the `/dev/sound` directory.

2. Verify that the audio device files have been created.

```
% ls /dev/sound
0      0ctl  1      1ctl  2      2ctl
```

3. Test the left and right USB speakers.

```
% cd /usr/share/audio/samples/au
% audioplay -d /dev/sound/1 -b 100 spacemusic.au
% audioplay -d /dev/sound/1 -b -100 spacemusic.au
```

4. Test the USB microphone.

```
% cd $HOME/au
% audiorecord -d /dev/sound/2 -p mic -t 30 test.au
```

▼ How to Identify Your System's Primary Audio Device

This procedure assumes that you have already connected USB audio devices.

1. Identify the state of your current audio device links.

For example:

```
% ls -lt /dev/audio*
lrwxrwxrwx  1 root    root          7 Jul 23 15:41 /dev/audio -> sound/0
lrwxrwxrwx  1 root    root         10 Jul 23 15:41 /dev/audioctl ->
sound/0ctl
% ls -lt /dev/sound/*
lrwxrwxrwx  1 root    other         66 Jul 23 14:21 /dev/sound/0 ->
../../devices/pci@1f,4000/ebus@1/SUNW,CS4231@14,200000:sound,audio
lrwxrwxrwx  1 root    other         69 Jul 23 14:21 /dev/sound/0ctl ->
../../devices/pci@1f,4000/ebus@1/SUNW,CS4231@14,200000:sound,audioctl
%
```

The primary audio device, `/dev/audio`, is currently pointing to the onboard audio, which is `/dev/sound/0`.

2. (Optional) Add a new USB audio device.

3. Examine your system's new audio links.

For example:

```
% ls -lt /dev/audio*
lrwxrwxrwx  1 root    root          7 Jul 23 15:46 /dev/audio -> sound/1
lrwxrwxrwx  1 root    root         10 Jul 23 15:46 /dev/audioctl ->
sound/1ctl
% ls -lt /dev/sound/*
```

```

lrwxrwxrwx 1 root root 74 Jul 23 15:46 /dev/sound/l1 ->
../../../../devices/pci@1f,4000/usb@5/hub@1/device@3/sound-control@0:sound,...
lrwxrwxrwx 1 root root 77 Jul 23 15:46 /dev/sound/lctl1 ->
../../../../devices/pci@1f,4000/usb@5/hub@1/device@3/sound-control@0:sound,...
lrwxrwxrwx 1 root other 66 Jul 23 14:21 /dev/sound/0 ->
../../../../devices/pci@1f,4000/ebus@1/SUNW,CS4231@14,200000:sound,audio
lrwxrwxrwx 1 root other 69 Jul 23 14:21 /dev/sound/oct1 ->
../../../../devices/pci@1f,4000/ebus@1/SUNW,CS4231@14,200000:sound,audioc1
%

```

Notice that the primary audio device, `/dev/audio`, is pointing to the newly plugged in USB audio device, `/dev/sound/l1`.

If you remove the USB audio device now, the primary audio device, `/dev/audio`, does not revert back to the onboard audio. See the following procedure for instructions on changing the primary audio device back to the system's onboard audio.

You can also examine your system's USB audio devices with the `prtconf` command and look for the USB device information.

```

% prtconf
.
.
.
usb, instance #0
  hub, instance #0
    mouse, instance #0
    keyboard, instance #1
    device, instance #0
      sound-control, instance #0
      sound, instance #0
      input, instance #0
.
.
.

```

▼ How to Change the Primary USB Audio Device

Follow these steps if you remove or change your USB audio devices and you want to make one particular audio device the primary audio device. The procedure changes the primary audio device to the onboard audio device as an example.

1. **Become superuser.**
2. **Close all audio applications.**
3. **Verify that the audio and USB drivers are loaded.**

```

# modinfo | grep -i audio
124 780e6a69 bb6e - 1 audiosup (Audio Device Support 1.12)
# modinfo | grep -i usb
48 13dba67 18636 199 1 ohci (USB OpenHCI Driver 1.31)

```

```

49 78020000 1dece - 1 usba (USBA: USB Architecture 1.37)
50 12e5f1f 35f 195 1 hubd (USB Hub Driver 1.4)
51 13ef53d 5e26 194 1 hid (USB HID Client Driver 1.16)
54 13f67f2 1b42 10 1 usbms (USB mouse streams 1.6)
56 127bbf0 2c74 11 1 uskbdm (USB keyboard streams 1.17)
#

```

4. Load and attach the onboard audio driver.

```
# devfsadm -i audiocs
```

The onboard audio driver is audiocs on a Sunblade 1000, and audiotcs on a Sunblade 100.

5. Verify that the primary audio device link is pointing to the onboard audio.

```

# ls -lt /dev/audio*
lrwxrwxrwx 1 root other 7 Jul 23 15:49 /dev/audio -> sound/0
lrwxrwxrwx 1 root other 10 Jul 23 15:49 /dev/audioc1 ->
sound/0c1
# ls -lt /dev/sound/*
lrwxrwxrwx 1 root other 66 Jul 23 14:21 /dev/sound/0 ->
../../devices/pci@1f,4000/ebus@1/SUNW,CS4231@14,200000:sound,audio
lrwxrwxrwx 1 root other 69 Jul 23 14:21 /dev/sound/0c1 ->
../../devices/pci@1f,4000/ebus@1/SUNW,CS4231@14,200000:sound,audioc1
#

```

6. Confirm the onboard audio is the primary audio device.

```
% audioplay /usr/demo/SOUND/sounds/bark.au
```

The audioplay command defaults to the onboard audio device.

7. (Optional) Unload all the audio drivers that can be unloaded before plugging in another USB audio device.

a. Close all the audio applications.

b. Display the audio driver information to verify that no audio drivers are currently loaded.

```

# modinfo | grep -i audio
60 78048000 bb6e - 1 audiosup (Audio Device Support 1.12)
61 78152000 39a97 - 1 mixer (Audio Mixer 1.49)
62 78118000 bf9f - 1 amsrc1 (Audio Sample Rate Conv. #1 1.3)
128 7805e000 14968 54 1 audiocs (CS4231 mixer audio driver 1.21)
#

```

c. Unload the audio drivers.

```

# modunload -i 0
# modinfo | grep -i audio
60 78048000 bb6e - 1 audiosup (Audio Device Support 1.12)
61 78152000 39a97 - 1 mixer (Audio Mixer 1.49)
#

```

At this point, `audiocs`, the onboard audio driver, has been unloaded and guaranteed not to be open. However, the primary audio device, `/dev/audio`, does not change if it is held open by an application.

8. (Optional) Plug in a USB audio device.

9. (Optional) Examine the new audio links.

```
% ls -lt /dev/audio*
lrwxrwxrwx 1 root root      7 Jul 23 16:12 /dev/audio -> sound/1
lrwxrwxrwx 1 root root     10 Jul 23 16:12 /dev/audiocctl ->
sound/1ctl
% ls -lt /dev/sound/*
lrwxrwxrwx 1 root root      77 Jul 23 16:12 /dev/sound/1ctl ->
../../devices/pci@1f,4000/usb@5/hub@1/device@3/sound-control@0:sound,...
lrwxrwxrwx 1 root root      74 Jul 23 16:12 /dev/sound/1 ->
../../devices/pci@1f,4000/usb@5/hub@1/device@3/sound-control@0:sound,...
lrwxrwxrwx 1 root root      66 Jul 23 15:59 /dev/sound/0 ->
../../devices/pci@1f,4000/ebus@1/SUNW,CS4231@14,200000:sound,audio
lrwxrwxrwx 1 root root      69 Jul 23 15:59 /dev/sound/0ctl ->
../../devices/pci@1f,4000/ebus@1/SUNW,CS4231@14,200000:sound,aud...
%
```

▼ How to Remove Unused USB Audio Device Links

Use this procedure if a USB audio device is removed while the system is powered off. It is possible that removing the USB audio device while the system is powered off will leave the `/dev/audio` device still pointing to a `/dev/sound/*` device that doesn't exist.

1. Become superuser.
2. Close all audio applications.
3. Remove the unused audio links.

```
# devfsadm -C -c audio
```

Troubleshooting USB Audio Device Problems

This section describes how to troubleshoot USB audio device problems.

Solving USB Speaker Problems

Sometimes USB speakers do not produce any sound even though the driver is attached and the volume is set to high. Hot-plugging the device might not change this behavior.

The workaround is to power cycle the USB speakers.

Key Points of Audio Device Ownership

Keep the following key points of audio device ownership in mind when working with audio devices.

- When you plug in a USB audio device and you are logged in on the console, the console is the owner of the `/dev/*` entries. This situation means you can use the audio device as long as you are logged into the console.
- If you are not logged into the console when you plug in a USB audio device, root becomes the owner of the device. However, if you log into the console and attempt to access the USB audio device, device ownership changes to the console. For more information, see `logindevperm(4)`.
- When you remotely login with the `rlogin` command and attempt to access the USB audio device, the ownership does not change. This means that, for example, unauthorized users cannot listen to conversations over a microphone owned by someone else.

Hot-Plugging USB Devices With the `cfgadm` Command (Task Map)

Task	Description	For Instructions
1. Display USB device information	Display information about USB devices and buses.	"How to Display USB Device Information" on page 425
2. Unconfigure a USB device	Logically unconfigure a USB device that is still physically connected to the system.	"How to Unconfigure a USB Device" on page 426
3. Configure a USB device	Configure a USB device that was previously unconfigured.	"How to Configure a USB Device" on page 427

Task	Description	For Instructions
4. Logically disconnect a USB device	You can logically disconnect a USB device if you are not physically near the system.	"How to Logically Disconnect a USB Device" on page 427
5. Logically connect a USB device	Logically connect a USB device that was previously logically disconnected or unconfigured.	"How to Logically Connect a USB Device" on page 427
6. Disconnect a USB device subtree	Disconnect a USB device subtree, which is the hierarchy (or tree) of devices below a hub.	"How to Logically Disconnect a USB Device Subtree" on page 428
7. Reset a USB device	Reset a USB device to logically remove and recreate the device.	"How to Reset a USB Device" on page 428

Hot-Plugging USB Devices With the `cfgadm` Command

You can add and remove a USB device from a running system without using the `cfgadm` command. However, a USB device can also be *logically* hot-plugged without physically removing the device. This scenario is convenient when you are working remotely and you need to disable or reset a non-functioning USB device. The `cfgadm` command also provides a way to display the USB device tree including manufacturer and product information.

The `cfgadm` command displays information about attachment points, which are locations in the system where dynamic reconfiguration operations can occur. An attachment point consists of:

- An occupant, which represents a hardware resource that might be configured into the system, and
- A receptacle, which is the location that accepts the occupant.

Attachment points are represented by logical and physical attachment point IDs (`Ap_Ids`). The physical `Ap_Id` is the physical pathname of the attachment point. The logical `Ap_Id` is a user-friendly alternative for the physical `Ap_Id`. For more information on `Ap_Ids`, see `cfgadm_usb(1M)`.

The `cfgadm` command provides the following USB device status information.

Receptacle State	Description
empty/unconfigured	The device is not connected.
disconnected/unconfigured	The device is logically disconnected and unavailable. The devinfo node is removed even though the device could still be physically connected.
connected/unconfigured	The device is logically connected, but unavailable. The devinfo node is present.
connected/configured	The device is connected and available.

The following sections describe how to hot-plugging a USB device with the `cfgadm` command. All of the sample USB device information in these sections has been truncated to focus on relevant information.

How to Display USB Device Information

Use the `prtconf` command to display information about USB devices.

```
$ prtconf
usb, instance #0
  hub, instance #2
    device, instance #8
      interface (driver not attached)
    printer (driver not attached)
    mouse, instance #14
    device, instance #9
      keyboard, instance #15
      mouse, instance #16
    storage, instance #7
      disk (driver not attached)
    communications, instance #10
      modem (driver not attached)
      data (driver not attached)
  storage, instance #0
    disk (driver not attached)
  storage, instance #1
    disk (driver not attached)
```

Use the `cfgadm` command to display USB bus information. For example:

```
% cfgadm
Ap_Id                               Type           Receptacle  Occupant    Condition
usb0/4.5                             usb-hub        connected   configured  ok
usb0/4.5.1                           usb-device     connected   configured  ok
usb0/4.5.2                           usb-printer    connected   configured  ok
usb0/4.5.3                           usb-mouse      connected   configured  ok
usb0/4.5.4                           usb-device     connected   configured  ok
usb0/4.5.5                           usb-storage    connected   configured  ok
```

usb0/4.5.6	usb-communi	connected	configured	ok
usb0/4.5.7	unknown	empty	unconfigured	ok
usb0/4.6	usb-storage	connected	configured	ok
usb0/4.7	usb-storage	connected	configured	ok

In the preceding example, `usb0/4.5.1` identifies a device connected to port 1 of the second-level external hub, which is connected to port 5 of first-level external hub, which is connected to the first USB controller's root hub, port 4.

Use the following `cfgadm` command to display specific USB device information. For example:

```
% cfgadm -l -s "cols=ap_id:info"
Ap_Id      Information
usb0/4.5.1 Mfg: Inside Out Networks Product: Edgeport/421 NConfigs:
1 Config: 0 : ...
usb0/4.5.2 Mfg: <undef> Product: <undef> NConfigs: 1 Config: 0
<no cfg str descr>
usb0/4.5.3 Mfg: Mitsumi Product: Apple USB Mouse NConfigs: 1 Config: 0
<no cfg str descr>
usb0/4.5.4 Mfg: NMB Product: NMB USB KB/PS2 M NConfigs: 1 Config: 0
usb0/4.5.5 Mfg: Hagiwara Sys-Com Product: SmartMedia R/W NConfigs:
1 Config: 0 : Default
usb0/4.5.6 Mfg: 3Com Inc. Product: U.S.Robotics 56000 Voice USB Modem
NConfigs: 2 ... usb0/4.5.7
usb0/4.6 Mfg: Iomega Product: USB Zip 250 NConfigs: 1 Config: 0
: Default
usb0/4.7 Mfg: Iomega Product: USB Zip 100 NConfigs: 1 Config: 0
: Default
#
```

▼ How to Unconfigure a USB Device

You can unconfigure a USB device that is still physically connected to the system, but a driver will never attach to it. After the USB device is unconfigured, the device is visible in the `prtconf` output.

1. Become superuser.

2. Unconfigure the USB device.

```
# cfgadm -c unconfigure usb0/4.7
Unconfigure the device: /devices/pci@8,700000/usb@5,3/hub@4:4.7
This operation will suspend activity on the USB device
Continue (yes/no)? y
```

3. Verify that the device is unconfigured.

```
# cfgadm
Ap_Id      Type      Receptacle  Occupant  Condition
usb0/4.5   usb-hub   connected   configured ok
usb0/4.5.1 usb-device connected   configured ok
```

usb0/4.5.2	usb-printer	connected	configured	ok
usb0/4.5.3	usb-mouse	connected	configured	ok
usb0/4.5.4	usb-device	connected	configured	ok
usb0/4.5.5	usb-storage	connected	configured	ok
usb0/4.5.6	usb-communi	connected	configured	ok
usb0/4.5.7	unknown	empty	unconfigured	ok
usb0/4.6	usb-storage	connected	configured	ok
usb0/4.7	usb-storage	connected	unconfigured	ok

▼ How to Configure a USB Device

1. Become superuser.
2. Configure a USB device.

```
# cfgadm -c configure usb0/4.7
```

3. Verify that the USB device is configured.

```
# cfgadm usb0/4.7
Ap_Id                Type                Receptacle  Occupant    Condition
usb0/4.7            usb-storage        connected   configured  ok
```

▼ How to Logically Disconnect a USB Device

If you want to remove a USB device from the system and the `prtconf` output, but you are not physically near the system, just logically disconnect the USB device. The device is still physically connected, but it is logically disconnected, unusable, and not visible to the system.

1. Become superuser.
2. Disconnect a USB device.

```
# cfgadm -c disconnect -y usb0/4.7
```

3. Verify that the device is disconnected.

```
# cfgadm usb0/4.7
Ap_Id                Type                Receptacle  Occupant    Condition
usb0/4.7            unknown            disconnected  unconfigured ok
```

▼ How to Logically Connect a USB Device

Use this procedure to logically connect a USB device that was previously logically disconnected or unconfigured.

1. Become superuser.

2. Connect a USB device.

```
# cfgadm -c configure usb0/4.7
```

3. Verify that the device is connected.

```
# cfgadm usb0/4.7
Ap_Id          Type          Receptacle  Occupant    Condition
usb0/4.7       usb-storage   connected   configured  ok
```

The device is now available and visible to the system.

▼ How to Logically Disconnect a USB Device Subtree

Use this procedure to disconnect a USB device subtree, which is the hierarchy (or tree) of devices below a hub.

1. Become superuser.

2. Remove a USB device subtree.

```
# cfgadm -c disconnect -y usb0/4
```

3. Verify that the USB device subtree is disconnected.

```
# cfgadm usb0/4
Ap_Id          Type          Receptacle  Occupant    Condition
usb0/4         unknown       disconnected  unconfigured ok
```

▼ How to Reset a USB Device

If a USB device behaves erratically, use the `cfgadm` command to reset the device, which logically removes and recreates the device.

1. Become superuser.

2. Make sure the device is not in use.

3. Reset the device.

```
# cfgadm -x usb_reset -y usb0/4.7
```

4. Verify that the device is connected.

```
# cfgadm usb0/4.7
Ap_Id          Type          Receptacle  Occupant    Condition
usb0/4.7       usb-storage   connected   configured  ok
```

Accessing Devices (Overview)

This chapter provides information about how to access the devices on a system.

This is a list of the overview information in this chapter.

- “Accessing Devices” on page 429
- “Logical Disk Device Names” on page 431
- “Logical Tape Device Names” on page 434
- “Logical Removable Media Device Names” on page 435

For overview information about configuring devices, see Chapter 27.

Accessing Devices

You need to know how to specify device names when using commands to manage disks, file systems, and other devices. In most cases, you can use logical device names to represent devices that are connected to the system. Both logical and physical device names are represented on the system by logical and physical device files.

How Device Information Is Created

When a system is booted for the first time, a device hierarchy is created to represent all the devices connected to the system. The kernel uses the device hierarchy information to associate drivers with their appropriate devices, and provides a set of pointers to the drivers that perform specific operations. For more information on device hierarchy, see *OpenBoot 3.x Command Reference Manual*.

How Devices Are Managed

The `devfsadm` command manages the special device files in the `/dev` and `/devices` directories. By default, the `devfsadm` command attempts to load every driver in the system and attach to all possible device instances. Then, `devfsadm` creates the device files in the `/devices` directory and the logical links in the `/dev` directory. In addition to managing the `/dev` and `/devices` directories, the `devfsadm` command also maintains the `path_to_inst(4)` instance database.

Both reconfiguration boot processing and updating the `/dev` and `/devices` directories in response to dynamic reconfiguration events is handled by `devfsadmd`, the daemon version of the `devfsadm` command. This daemon is started from the `/etc/rc*` scripts when a system is booted.

Since the `devfsadmd` daemon automatically detects device configuration changes generated by any reconfiguration event, there is no need to run this command interactively.

For more information, see `devfsadm(1M)`.

Device Naming Conventions

Devices are referenced in three ways in the Solaris environment.

- Physical device name – Represents the full device pathname in the device information hierarchy. Physical device names are displayed by using the following commands:
 - `dmesg`
 - `format`
 - `sysdef`
 - `prtconf`

Physical device files are found in the `/devices` directory.

- Instance name – Represents the kernel's abbreviation name for every possible device on the system. For example, `sd0` and `sd1` represent the instance names of two disk devices. Instance names are mapped in the `/etc/path_to_inst` file and are displayed by using the following commands:
 - `dmesg`
 - `sysdef`
 - `prtconf`
- Logical device name – Used with most file system commands to refer to devices. For a list of file commands that use logical device names, see Table 30–1. Logical device files in the `/dev` directory are symbolically linked to physical device files in the `/devices` directory.

Logical Disk Device Names

Logical device names are used to access disk devices when you:

- Add a new disk to the system
- Move a disk from one system to another system
- Access or mount a file system residing on a local disk
- Back up a local file system

Many administration commands take arguments that refer to a disk slice or file system.

Refer to a disk device by specifying the subdirectory to which it is symbolically linked, either `/dev/dsk` or `/dev/rdsk`, followed by a string identifying the particular controller, disk, and slice.

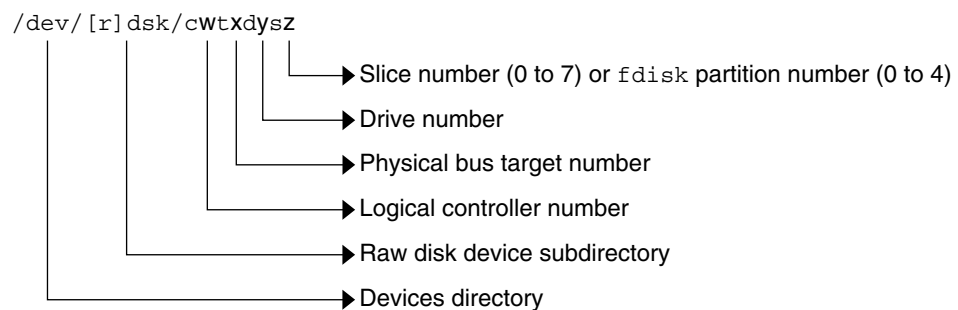

FIGURE 30-1 Logical Device Names

Specifying the Disk Subdirectory

Disk and file administration commands require the use of either a *raw* (or *character*) device interface, or a *block* device interface. The distinction is made by how data is read from the device.

Raw device interfaces transfer only small amounts of data at a time. Block device interfaces include a buffer from which large blocks of data are read at once.

Different commands require different interfaces.

- When a command requires the raw device interface, specify the `/dev/rdsk` subdirectory. (The “r” in `rdsk` stands for “raw.”)
- When a command requires the block device interface, specify the `/dev/dsk` subdirectory.

- When you are not sure whether a command requires use of `/dev/dsk` or `/dev/rdisk`, check the man page for that command.

The following table shows which interface is required for some commonly used disk and file system commands.

TABLE 30-1 Device Interface Type Required by Some Frequently Used Commands

Command	Interface Type	Example of Use
<code>df(1M)</code>	Block	<code>df /dev/dsk/c0t3d0s6</code>
<code>fsck(1M)</code>	Raw	<code>fsck -p /dev/rdsk/c0t0d0s0</code>
<code>mount(1M)</code>	Block	<code>mount /dev/dsk/c1t0d0s7 /export/home</code>
<code>newfs(1M)</code>	Raw	<code>newfs /dev/rdsk/c0t0d1s1</code>
<code>prtvtoc(1M)</code>	Raw	<code>prtvtoc /dev/rdsk/c0t0d0s2</code>

Specifying the Slice

The string that you use to identify a specific slice on a specific disk depends on the controller type, either direct or bus-oriented. The following table describes the different types of direct or bus-oriented controllers on different platforms.

TABLE 30-2 Controller Types

Direct controllers	Bus-Oriented Controllers
IDE (x86)	SCSI (SPARC/x86)
	FCAL (SPARC)
	ATA (SPARC/x86)

The conventions for both types of controllers are explained in the following subsections.

Note – Controller numbers are assigned automatically at system initialization. The numbers are strictly logical and imply no direct mapping to physical controllers.

x86: Disks With Direct Controllers

To specify a slice on a disk with an IDE controller on an x86 based system, follow the naming convention shown in the following figure.

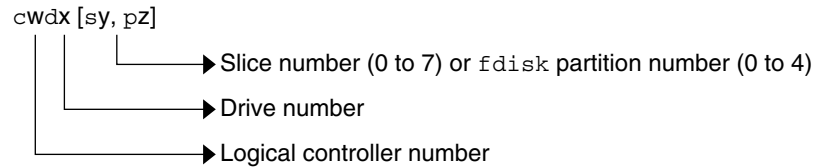

FIGURE 30-2 x86: Disks with Direct Controllers

To indicate the entire Solaris `fdisk` partition, specify slice 2 (`s2`).

If you have only one controller on your system, `w` is usually 0.

SPARC: Disks With Bus-Oriented Controllers

To specify a slice on a disk with a bus-oriented controller, SCSI for instance, on a SPARC based system, follow the naming convention shown in the following figure.

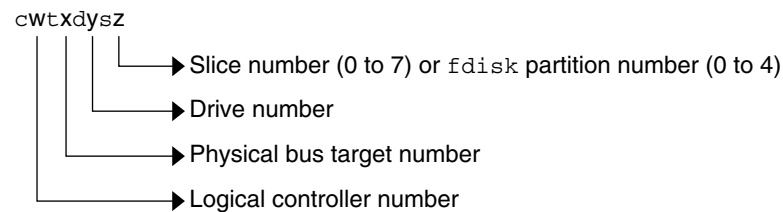

FIGURE 30-3 SPARC: Disks With Bus-Oriented Controllers

On a SPARC based system with directly connected disks such as the IDE disks on a Ultra10, the naming convention is the same as that for systems with bus-oriented controllers.

If you have only one controller on your system, `w` is usually 0.

For SCSI controllers, `x` is the target address set by the switch on the back of the unit, and `y` is the logical unit number (LUN) of the drive attached to the target. If the disk has an embedded controller, `y` is usually 0.

To indicate the whole disk, specify slice 2 (`s2`).

x86: Disks With SCSI Controllers

To specify a slice on a disk with a SCSI controller on an x86 based system, follow the naming convention shown in the following figure.

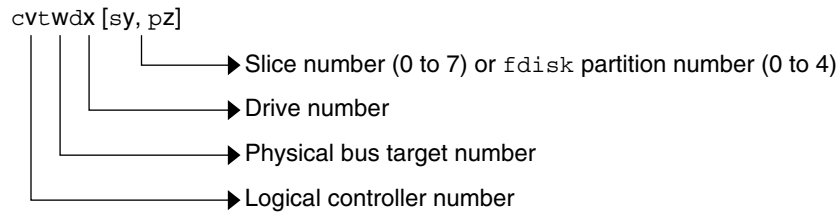

FIGURE 30-4 x86: Disks with SCSI Controllers

If you have only one controller on your system, *v* is usually 0.

For SCSI controllers, *w* is the target address set by the switch on the back of the unit, and *x* is the logical unit number (LUN) of the drive attached to the target. If the disk has an embedded controller, *x* is usually 0.

To indicate the entire Solaris `fdisk` partition, specify slice 2 (`s2`).

Logical Tape Device Names

Logical tape device files are found in the `/dev/rmt/*` directory as symbolic links from the `/devices` directory.

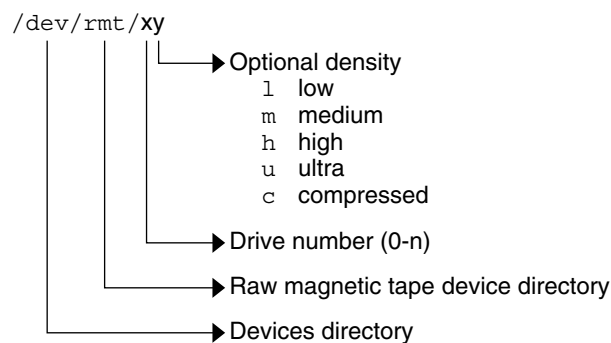

FIGURE 30-5 Logical Tape Device Names

The first tape device connected to the system is 0 (`/dev/rmt/0`). Tape density values (l, m, h, c, and u) are described in Chapter 52.

Logical Removable Media Device Names

Since removable media is managed by volume management (`vol`), the logical device name is usually not used unless you want to mount the media manually.

The logical device name that represents the removable media devices on a system are described in Chapter 18.

Managing Disks Topics

This topic map lists the chapters that provide information on managing disks.

Chapter 32	Provides an overview of Solaris disk slices and an introduction to the <code>format</code> utility.
Chapter 33	Provides step-by-step instructions for formatting a disk, examining disk labels, and repairing a defective disk sector.
Chapter 34	Provides step-by-step instructions for adding a disk to a SPARC based system.
Chapter 35	Provides step-by-step instructions for adding a disk to an x86 based system.
Chapter 36	Provides a description of the <code>format</code> utility's menu and commands. This chapter also includes information about the <code>format.dat</code> file, rules for providing input to <code>format</code> commands, and instructions on using the help facility.

Managing Disks (Overview)

This chapter provides overview information about Solaris disk slices and introduces the `format` utility.

This is a list of overview information in this chapter.

- “What’s New in Disk Management in the Solaris 9 8/03 Release?” on page 439
- “What’s New in Disk Management in the Solaris 9 Release?” on page 443
- “Where to Find Disk Management Tasks” on page 444
- “Overview of Disk Management” on page 444
- “Disk Terminology” on page 445
- “About Disk Slices” on page 445
- “The `format` Utility” on page 450
- “About Disk Labels” on page 454
- “Dividing a Disk Into Slices” on page 456

For instructions on how to add a disk to your system, see Chapter 34 or Chapter 35.

What’s New in Disk Management in the Solaris 9 8/03 Release?

This section describes a new disk management feature in this Solaris release.

SPARC: Multiterabyte Volume Support With EFI Disk Label

This Solaris release provides support for disks that are larger than 1 terabyte on systems running a 64-bit Solaris kernel. The Extensible Firmware Interface (EFI) disk label is not available for disks connected to a system running a 32-bit Solaris kernel, such as a system running the Solaris x86 Platform Edition.

You can download the EFI specification at http://www.intel.com/technology/efi/main_specification.htm.

The EFI label provides support for physical disks and virtual disk volumes. This release also includes updated disk utilities for managing disks greater than 1 terabyte. The UFS file system is compatible with the EFI disk label, and you can create a UFS file system greater than 1 terabyte. For information on creating a multiterabyte UFS file system, see “SPARC: Support of Multiterabyte UFS File Systems” on page 523.

The Solaris Volume Manager software can also be used to manage disks greater than 1 terabyte in this Solaris release. For information on using Solaris Volume Manager, see *Solaris Volume Manager Administration Guide*.

The VTOC label is still available for disks less than 1 terabyte in size. If you are only using disks smaller than 1 terabyte on your systems, managing disks will be the same as in previous Solaris releases. In addition, you can use the `format -e` command to label a disk less than 1 terabyte with an EFI label. For more information, see “Example—Labeling a Disk Less Than 1 Terabyte with an EFI Label” on page 469.

Comparison of the EFI Label and the VTOC Label

The EFI disk label differs from the VTOC disk label in the following ways:

- Provides support for disks greater than 1 terabyte in size.
- Provides usable slices 0–6, where slice 2 is just another slice.
- Partitions (or slices) cannot overlap with the primary or backup label, nor with any other partitions. The size of the EFI label is usually 34 sectors, so partitions start at sector 34. This feature means no partition can start at sector zero (0).
- No cylinder, head, or sector information is stored in the label. Sizes are reported in blocks.
- Information that was stored in the alternate cylinders area, the last two cylinders of the disk, is now stored in slice 8.
- If you use the `format` utility to change partition sizes, the `unassigned` partition tag is assigned to partitions with sizes equal to zero. By default, the `format` utility assigns the `usr` partition tag to any partition with a size greater than zero. You can use the partition change menu to reassign partition tags after the partitions are changed. However, you cannot change a partition with a non-zero size to the `unassigned` partition tag.

Restrictions of the EFI Disk Label

Keep the following restrictions in mind when determining whether to use disks greater than 1 terabyte is appropriate for your environment:

- The layered software products intended for systems with EFI-labeled disks might be incapable of accessing a disk with an EFI disk label.
- A disk with an EFI disk label is not recognized on systems running previous Solaris releases.
- The EFI disk label is not supported on IDE disks.
- You cannot boot from a disk with an EFI disk label.
- You cannot use the Solaris Management Console's Disk Manager Tool to manage disks with EFI labels. Use the `format` utility or the Solaris Management Console's Enhanced Storage Tool to manage disks with EFI labels, after you use the `format` utility to partition the disk.
- The EFI specification prohibits overlapping slices. The whole disk is represented by `cxydz`.
- UFS file systems are compatible with the EFI disk label. Starting in the Solaris 9 8/03 release, you can create a UFS file system that is greater than 1 terabyte. For more information multiterabyte UFS file systems, see "SPARC: Support of Multiterabyte UFS File Systems" on page 523.

The unbundled Sun QFS file system is also available if you need to create file systems greater than 1 terabyte. For information on the Sun QFS file system, see <http://docs.sun.com/db/doc/816-2542-10>.

- Provides information about disk or partition sizes in sectors and blocks, but not in cylinders and heads.
- The following `format` options are either not supported or are not applicable on disks with EFI labels:
 - The `save` option is not supported because disks with EFI labels do not need an entry in the `format.dat` file.
 - The `backup` option is not applicable because the disk driver finds the primary label and writes it back to the disk.

Installing a System With an EFI-Labeled Disk

The Solaris installation utilities automatically recognize disks with EFI labels, but cannot use the Solaris installation utilities to repartition these disks. You must use the `format` utility to repartition this disk before or after installation. The Solaris Upgrade and Live Upgrade utilities also recognize a disk with an EFI label. However, you cannot boot a system from an EFI-labeled disk.

After the Solaris release is installed on a system with an EFI-labeled disk, the partition table looks similar to the following:

Current partition table (original):
 Total disk sectors available: 2576924638 + 16384 (reserved sectors)

Part	Tag	Flag	First Sector	Size	Last Sector
0	root	wm	34	1.20TB	2576924636
1	unassigned	wm	0	0	0
2	unassigned	wm	0	0	0
3	unassigned	wm	0	0	0
4	unassigned	wm	0	0	0
5	unassigned	wm	0	0	0
6	unassigned	wm	0	0	0
8	reserved	wm	2576924638	8.00MB	2576941021

Managing Disks With EFI Disks Labels

Use the following table to locate information on managing disks with EFI disk labels.

Task	For More Information
In the system is already installed, connect the disk to the system and perform a reconfiguration boot.	"SPARC: Adding a System Disk or a Secondary Disk (Task Map)" on page 481
Repartition the disk with the <code>format</code> utility, if necessary.	"SPARC: How to Create Disk Slices and Label a Disk" on page 484
Create disk volumes, and if needed, create soft partitions with Solaris Volume Manager.	"Storage Management Concepts" in <i>Solaris Volume Manager Administration Guide</i>
Create UFS file systems for the new disk with the <code>newfs</code> command.	"SPARC: How to Create File Systems" on page 489
Or, create a QFS file system.	http://docs.sun.com/db/coll/20445.2

Cloning a Disk with an EFI Label

In previous Solaris releases, slice 2 (`s2`) was used to represent the whole disk. You could use the `dd` command to clone or copy disks by using syntax similar to the following:

```
dd if=/dev/rdisk/c0t0d0s2 of=/dev/rdisk/c0t2d0s2 bs=128k
```

Now, you must use a slightly different procedure to clone or copy disks larger than 1 terabyte so that the UUID of cloned disks are unique. For example:

1. Use the `dd` command to clone the disk with an EFI label:

```
# dd if=/dev/rdisk/c0t0d0 of=/dev/rdisk/c0t2d0 bs=128k
```

2. Pipe the `prtvtoc` output of the disk to be copied to the `fmthard` command to create a new label for the cloned disk.

```
# prtvtoc /dev/rdisk/c0t0d0 | fmthard -s - /dev/rdisk/c0t2d0
```



Caution – If you do not create a new label for the cloned disk, other software products might corrupt data on EFI-labeled disks if they encounter duplicate UUIDs.

Troubleshooting Problems With EFI Disk Labels

Use the following error messages and solutions to troubleshooting problems with EFI-labeled disks.

Error Message

```
Dec  3 09:26:48 holoship scsi: WARNING: /sbus@a,0/SUNW,socal@d,10000/
sf@1,0/ssd@w50020f23000002a4,0 (ssd1):
Dec  3 09:26:48 holoship disk has 2576941056 blocks, which is too large
for a 32-bit kernel
```

Cause

You attempted to boot a system running a 32-bit SPARC kernel with a disk greater than 1 terabyte.

Solution

Boot a system running a 64-bit SPARC kernel with a disk greater than 1 terabyte.

Error Message

```
Dec  3 09:12:17 holoship scsi: WARNING: /sbus@a,0/SUNW,socal@d,10000/
sf@1,0/ssd@w50020f23000002a4,0 (ssd1):
Dec  3 09:12:17 holoship corrupt label - wrong magic number
```

Cause

You attempted to add this disk to a system running an older Solaris release.

Solution

Add this disk to a system running the Solaris release that supports the EFI disk label.

What's New in Disk Management in the Solaris 9 Release?

This section describes new disk management features in the Solaris 9 release.

Solaris Volume Manager and Soft Partitioning

The previously unbundled Solstice DiskSuite™ product is now part of the Solaris 9 release and is called Solaris Volume Manager. Solaris Volume Manager's new partitioning feature, *soft partitioning*, enables more than eight partitions per disk.

For general information about Solaris Volume Manager, see "Storage Management Concepts" in *Solaris Volume Manager Administration Guide*. For information on soft partitioning, see "Soft Partitions (Overview)" in *Solaris Volume Manager Administration Guide*.

Where to Find Disk Management Tasks

Use these references to find step-by-step instructions for managing disks.

Disk Management Task	For More Information
Format a disk and examine a disk label	Chapter 33
Add a new disk to a SPARC system	Chapter 34
Add a new disk to an x86 system	Chapter 35
Hot-Plug a SCSI or PCI disk	Chapter 28

Overview of Disk Management

The management of disks in the Solaris environment usually involves setting up the system and running the Solaris installation program to create the appropriate disk slices and file systems and to install the operating system. Occasionally, you might need to use the `format` utility to add a new disk drive or replace a defective one.

Note – The Solaris operating environment runs on two types of hardware, or platforms—SPARC and x86. The Solaris operating environment runs on both 64-bit and 32-bit address spaces. The information in this document pertains to both platforms and address spaces unless called out in a special chapter, section, note, bullet, figure, table, example, or code example.

Disk Terminology

Before you can effectively use the information in this section, you should be familiar with basic disk architecture. In particular, you should be familiar with the following terms:

Disk Term	Description
Track	A concentric ring on a disk that passes under a single stationary disk head as the disk rotates.
Cylinder	The set of tracks with the same nominal distance from the axis about which the disk rotates.
Sector	Section of each disk platter. A sector holds 512 bytes.
Block	A data storage area on a disk. A disk block is 512 bytes.
Disk controller	A chip and its associated circuitry that controls the disk drive.
Disk label	The first sector of a disk that contains disk geometry and partition information.
Device driver	A device driver is a kernel module that controls a hardware or virtual device.

For additional information, see the product information from your disk's manufacturer.

About Disk Slices

Files stored on a disk are contained in file systems. Each file system on a disk is assigned to a *slice*, which is a group of sectors set aside for use by that file system. Each disk slice appears to the operating system (and to the system administrator) as though it were a separate disk drive.

For information about file systems, see Chapter 38.

Note – Slices are sometimes referred to as partitions. This book uses *slice* but certain interfaces, such as the `format` utility, refer to slices as partitions.

When setting up slices, remember these rules:

- Each disk slice holds only one file system.
- No file system can span multiple slices.

Slices are set up slightly differently on SPARC and x86 platforms. The following table summarizes the differences.

TABLE 32-1 Slice Differences on Platforms

SPARC Platform	x86 Platform
Whole disk is devoted to Solaris environment.	Disk is divided into <code>fdisk</code> partitions, one <code>fdisk</code> partition per operating environment.
VTOC – Disk is divided into 8 slices, numbered 0–7.	VTOC – The Solaris <code>fdisk</code> partition is divided into 10 slices, numbered 0–9.
EFI – Disk is divided into 7 slices, numbered 0–6.	

SPARC: Disk Slices

The following table describes the slices on a SPARC based system.

TABLE 32-2 SPARC: Customary Disk Slices

Slice	File System	Usually Found on Client or Server Systems?	Comments
0	root (/)	Both	Holds files and directories that make up the operating system. EFI – You cannot boot from a disk with an EFI label.
1	swap	Both	Provides virtual memory, or <i>swap space</i> .
2	—	Both	VTOC – Refers to the entire disk, by convention. The size of this slice should not be changed. EFI – Optional slice to be defined based on your site's needs.

TABLE 32-2 SPARC: Customary Disk Slices (Continued)

Slice	File System	Usually Found on Client or Server Systems?	Comments
3	/export	Both	Optional slice that can be defined based on your site's needs. Can be used on a server to hold alternative versions of operating systems that are required by client systems.
4		Both	Optional slice to be defined based on your site's needs.
5		Both	Optional slice to be defined based on your site's needs. Can be used to hold application software added to a system. If a slice is not allocated for the /opt file system during installation, the /opt directory is put in slice 0.
6	/usr	Both	Holds operating system commands (also known as <i>executables</i>). This slice also holds documentation, system programs (<i>init</i> and <i>syslogd</i> , for example) and library routines.
7	/home or /export/home	Both	VTOC – Holds files that are created by users. EFI – Not applicable.
8	N/A	N/A	VTOC – Not applicable. EFI – A reserved slice created by default. This area is similar to the VTOC's alternate cylinders. Do not modify nor delete this slice.

x86: Disk Slices

On x86 based systems, disks are divided into `fdisk` partitions. An `fdisk` partition is a section of the disk that reserved for a particular operating environment, such as the Solaris release.

The Solaris release places ten slices, numbered 0–9, on a Solaris `fdisk` partition as shown in the following table.

TABLE 32-3 x86: Customary Disk Slices

Slice	File System	Usually Found on Client or Server Systems?	Purpose
0	root (/)	Both	Holds the files and directories that make up the operating system.
1	swap	Both	Provides virtual memory, or <i>swap space</i> .
2	—	Both	Refers to the entire disk, by convention. The size of this slice should not be changed.
3	/export	Both	Optional slice to be defined based on your site's needs. Can be used on a server to hold alternative versions of operating systems that are required by client systems.
4			Optional slice to be defined based on your site's needs.
5		Both	Optional slice to be defined based on your site's needs. Can be used to hold application software added to a system. If a slice is not allocated for the /opt file system during installation, the /opt directory is put in slice 0.
6	/usr	Both	Holds operating system commands (also known as <i>executables</i>). This slice also holds documentation, system programs (<i>init</i> and <i>syslogd</i> , for example) and library routines.
7	/home or /export/home	Both	Holds files that are created by users.
8	—	Both	Contains information necessary for to boot the Solaris environment from the hard disk. The slice resides at the beginning of the Solaris <code>fdisk</code> partition (although the slice number itself does not indicate this fact), and is known as the boot slice.

TABLE 32-3 x86: Customary Disk Slices (Continued)

Slice	File System	Usually Found on Client or Server Systems?	Purpose
9	—	Both	Provides an area that is reserved for alternate disk blocks. Slice 9 is known as the alternate sector slice.

Using Raw Data Slices

The SunOS operating system stores the disk label in block 0 of each disk. So, third-party database applications that create raw data slices must not start at block 0, or the disk label will be overwritten and the data on the disk will be inaccessible.

Do not use the following areas of the disk for raw data slices, which are sometimes created by third-party database applications:

- Block 0 where the disk label is stored
- Slice 2, which represents the entire disk with a VTOC label

Slice Arrangements on Multiple Disks

Although a single large disk can hold all slices and their corresponding file systems, two or more disks are often used to hold a system's slices and file systems.

Note – A slice cannot be split between two or more disks. However, multiple swap slices on separate disks are allowed.

For instance, a single disk might hold the root (/) file system, a swap area, and the /usr file system, while another disk holds the /export/home file system and other file systems that contain user data.

In a multiple disk arrangement, the disk that contains the operating system software and swap space (that is, the disk that holds the root (/) and /usr file systems and the slice for swap space) is called the *system disk*. Other disks are called *secondary disks* or *non-system disks*.

When you arrange a system's file systems on multiple disks, you can modify file systems and slices on the secondary disks without having to shut down the system or reload operating system software.

When you have more than one disk, you also increase input-output (I/O) volume. By distributing disk load across multiple disks, you can avoid I/O bottlenecks.

Determining Which Slices to Use

When you set up a disk's file systems, you choose not only the size of each slice, but also which slices to use. Your decisions about these matters depend on the configuration of the system to which the disk is attached and the software you want to install on the disk.

System configurations that need disk space are as follows:

- Servers
- Standalone systems

Each system configuration can use slices in a different way. The following table lists some examples.

TABLE 32-4 System Configurations and Slices

Slice	Servers	Standalone Systems
0	root	root
1	swap	swap
2	—	—
3	/export	—
6	/usr	/usr
7	/export/home	/home

For more information about system configurations, see "Overview of System Types" on page 120.

Note – The Solaris installation program provides default slice sizes based on the software you select for installation.

The format Utility

Read the following overview of the `format` utility and its uses before proceeding to the "how-to" or reference sections.

The `format` utility is a system administration tool that is used to prepare hard disk drives for use on your Solaris system.

The following table shows the features and associated benefits that the `format` utility provides.

TABLE 32-5 Features and Benefits of the `format` Utility

Feature	Benefit
Searches your system for all attached disk drives	Reports on the following: <ul style="list-style-type: none">■ Target location■ Disk geometry■ Whether the disk is formatted■ If the disk has mounted partitions
Retrieves disk labels	Convenient for repair operations
Repairs defective sectors	Allows administrators to repair disk drives with recoverable errors instead of sending the drive back to the manufacturer
Formats and analyzes a disk	Creates sectors on the disk and verifies each sector
Partitions a disk	Divides a disk into slices so individual file systems can be created on separate slices
Labels a disk	Writes disk name and configuration information to the disk for future retrieval (usually for repair operations)

The `format` utility options are fully described in Chapter 36.

When to Use the `format` Utility

Disk drives are partitioned and labeled by the Solaris installation program when you install the Solaris release. You can use the `format` utility to do the following:

- Display slice information
- Divide a disk into slices
- Add a disk drive to an existing system
- Format a disk drive
- Label a disk
- Repair a disk drive
- Analyze a disk for errors

The main reason a system administrator uses the `format` utility is to divide a disk into disk slices. These steps are covered in Chapter 34 and Chapter 35.

See the following section for guidelines on using the `format` utility.

Guidelines for Using the format Utility

TABLE 32-6 The format Utility Guidelines

Task	Guidelines	For More Information
Format a disk	<ul style="list-style-type: none">■ Any existing data is destroyed when you reformat a disk.■ The need for formatting a disk drive has dropped as more and more manufacturers ship their disk drives formatted and partitioned. You might not need to use the <code>format</code> utility when you add a disk drive to an existing system.■ If a disk has been relocated and is displaying a lot of disk errors, you can attempt to reformat it, which will automatically remap any bad sectors.	"How to Format a Disk" on page 463
Replace a system disk	<ul style="list-style-type: none">■ Data from the damaged system disk must be restored from a backup medium. Otherwise, the system will have to be reinstalled by using the installation program.	"SPARC: How to Connect a System Disk and Boot" on page 483 or "x86: How to Connect a System Disk and Boot" on page 492 or if the system must be reinstalled, <i>Solaris 9 12/03 Installation Guide</i>
Divide a disk into slices	<ul style="list-style-type: none">■ Any existing data is destroyed when you repartition and relabel a disk with existing slices.■ Existing data must be copied to backup media before the disk is repartitioned and restored.	"SPARC: How to Create Disk Slices and Label a Disk" on page 484 or "x86: How to Create Disk Slices and Label a Disk" on page 501
Add a secondary disk to an existing system	<ul style="list-style-type: none">■ Any existing data must be restored from backup media if the secondary disk is reformatted or repartitioned.	"SPARC: How to Connect a Secondary Disk and Boot" on page 483 or "x86: How to Connect a Secondary Disk and Boot" on page 493

TABLE 32-6 The `format` Utility Guidelines (Continued)

Task	Guidelines	For More Information
Repair a disk drive	<ul style="list-style-type: none">■ Some customer sites prefer to replace rather than repair defective drives. If your site has a repair contract with the disk drive manufacturer, you might not need to use the <code>format</code> utility to repair disk drives.■ The repair of a disk drive usually means that a bad sector is added to a defect list. New controllers remap bad sectors automatically with no system interruption.■ If the system has an older controller, you might need to remap a bad sector and restore any lost data.	"Repairing a Defective Sector" on page 476

Formatting a Disk

In most cases, disks are formatted by the manufacturer or reseller. So, they do not need to be reformatted when you install the drive. To determine if a disk is formatted, use the `format` utility. For more information, see "How to Determine if a Disk is Formatted" on page 463.

If you determine that a disk is not formatted, use the `format` utility to format the disk.

When you format a disk, you accomplish two steps:

- The disk media is prepared for use
- A list of disk defects based on a surface analysis is compiled



Caution – Formatting a disk is a destructive process because it overwrites data on the disk. For this reason, disks are usually formatted only by the manufacturer or reseller. If you think disk defects are the cause of recurring problems, you can use the `format` utility to do a surface analysis. However, be careful to use only the commands that do not destroy data. For details, see "How to Format a Disk" on page 463.

A small percentage of total disk space that is available for data is used to store defect and formatting information. This percentage varies according to disk geometry, and decreases as the disk ages and develops more defects.

Formatting a disk might take anywhere from a few minutes to several hours, depending on the type and size of the disk.

About Disk Labels

A special area of every disk is set aside for storing information about the disk's controller, geometry, and slices. That information is called the disk's *label*. Another term that is used to describe the disk label is the VTOC (Volume Table of Contents) on a disk with a VTOC label. To *label* a disk means to write slice information onto the disk. You usually label a disk after you change its slices.

If you fail to label a disk after you create slices, the slices will be unavailable because the operating system has no way of "knowing" about the slices.

Partition Table

An important part of the disk label is the *partition table*, which identifies a disk's slices, the slice boundaries (in cylinders), and the total size of the slices. You can display a disk's partition table by using the `format` utility. The following table describes partition table terminology.

TABLE 32-7 Partition Table Terminology

Partition Term	Value	Description
Number	0-7	VTOC – Partitions or slices, numbered 0-7. EFI – Partitions or slices, numbered 0-6.
Tag	0=UNASSIGNED 1=BOOT 2=ROOT 3=SWAP 4=USR 5=BACKUP 7=VAR 8=HOME 11=RESERVED	A numeric value that usually describes the file system mounted on this partition.
Flags	wm wu rm rm	The partition is writable and mountable. The partition is writable and unmountable. This is the default state of partitions that are dedicated for swap areas. (However, the <code>mount</code> command does not check the "not mountable" flag.) The partition is read only and mountable.

Partition flags and tags are assigned by convention and require no maintenance.

For more information on displaying the partition table, see "How to Display Disk Slice Information" on page 465 or "How to Examine a Disk Label" on page 469.

Displaying Partition Table Information

The following is an example of a partition table from a 4.0-Gbyte disk with a VTOC label displayed from the `format` utility:

Total disk cylinders available: 8892 + 2 (reserved cylinders)

Part	Tag	Flag	Cylinders	Size	Blocks
0	root	wm	1110 - 4687	1.61GB	(0/3578/0) 3381210
1	swap	wu	0 - 1109	512.00MB	(0/1110/0) 1048950
2	backup	wm	0 - 8891	4.01GB	(0/8892/0) 8402940
3	unassigned	wm	0	0	(0/0/0) 0
4	unassigned	wm	0	0	(0/0/0) 0
5	unassigned	wm	0	0	(0/0/0) 0
6	unassigned	wm	0	0	(0/0/0) 0
7	home	wm	4688 - 8891	1.89GB	(0/4204/0) 3972780

The partition table displayed by the `format` utility contains the following information:

Column Name	Description
Part	Partition (or slice number). See Table 32-7 for a description of this column.
Tag	Partition tag. See Table 32-7 for a description of this column.
Flags	Partition flag. See Table 32-7 for a description of this column.
Cylinders	The starting and ending cylinder number for the slice.
Size	The slice size in Mbytes.
Blocks	The total number of cylinders and the total number of sectors per slice in the far right column.
First Sector	EFI – The starting block number.
Last Sector	EFI – The ending block number.

The following is an example of a EFI disk label displayed by using the `prtvtoc` command.

```
# prtvtoc /dev/rdisk/c4t1d0s0
* /dev/rdisk/c4t1d0s0 partition map
*
* Dimensions:
*   512 bytes/sector
* 2576941056 sectors
* 2576940989 accessible sectors
*
* Flags:
*   1: unmountable
*  10: read-only
```

```

*
*
* Partition  Tag  Flags      First      Sector      Last
*           0    2    00          34    629145600  629145633
*           1    4    00    629145634    629145600  1258291233
*           6    4    00    1258291234    1318633404  2576924637
*           8    11   00    2576924638          16384  2576941021
*
* Flags:
*   1: unmountable
*  10: read-only
*

```

The `prtvtoc` command provides the following information:

Column Name	Description
Dimensions	This section describes the physical dimensions of the disk drive.
Flags	This section describes the flags listed in the partition table section. For a description of partition flags, see Table 32-7.
Partition (or Slice) Table	This section contains the following information:
Partition	Partition (or slice number). For a description of this column, see Table 32-7.
Tag	Partition tag. For a description of this column, see Table 32-7.
Flags	Partition flag. For a description of this column, see Table 32-7.
First Sector	The first sector of the slice.
Sector Count	The total number of sectors in the slice.
Last Sector	The last sector of the slice.
Mount Directory	The last mount point directory for the file system.

Dividing a Disk Into Slices

The `format` utility is most often used by system administrators to divide a disk into slices. The steps are as follows:

- Determining which slices are needed
- Determining the size of each slice
- Using the `format` utility to divide the disk into slices
- Labeling the disk with new slice information
- Creating the file system for each slice

The easiest way to divide a disk into slices is to use the `modify` command from the `partition` menu of the `format` utility. The `modify` command allows you to create slices by specifying the size of each slice without having to keep track of the starting cylinder boundaries. The `modify` command also keeps tracks of any disk space that remains in the “free hog” slice.

Using the Free Hog Slice

When you use the `format` utility to change the size of one or more disk slices, you designate a temporary slice that will expand and shrink to accommodate the resizing operations.

This temporary slice donates, or “frees,” space when you expand a slice, and receives, or “hogs,” the discarded space when you shrink a slice. For this reason, the donor slice is sometimes called the *free hog*.

The free hog slice exists only during installation or when you run the `format` utility. There is no permanent free hog slice during day-to-day operations.

For information on using the free hog slice, see “SPARC: How to Create Disk Slices and Label a Disk” on page 484 or “x86: How to Create Disk Slices and Label a Disk” on page 501.

Administering Disks (Tasks)

This chapter contains disk administration procedures. Many procedures described in this chapter are optional if you are already familiar with how disks are managed on systems running the Solaris release.

For information on the procedures associated with administering disks, see “Administering Disks (Task Map)” on page 459.

For overview information about disk management, see Chapter 32.

Administering Disks (Task Map)

Task	Description	For Instructions
Identify the disks on a system	If you are not sure of the types of disks on a system, use the <code>format</code> utility to identify the disk types.	“How to Identify the Disks on a System” on page 460
Format the disk	Determine whether a disk is already formatted by using the <code>format</code> utility. In most cases, disks are already formatted. Use the <code>format</code> utility if you need to format a disk.	“How to Determine if a Disk is Formatted” on page 463 “How to Format a Disk” on page 463
Display slice information	Display slice information by using the <code>format</code> utility.	“How to Display Disk Slice Information” on page 465

Task	Description	For Instructions
Label the disk	Create the disk label by using the <code>format</code> utility.	"How to Label a Disk" on page 467
Examine the disk label	Examine the disk label by using the <code>prtvtoc</code> command.	"How to Examine a Disk Label" on page 469
Recover a corrupted disk label	You can attempt to recover a disk label that was damaged due to a system or power failure.	"How to Recover a Corrupted Disk Label" on page 471
Create a <code>format .dat</code> entry	Create a <code>format .dat</code> entry to support a third-party disk.	"How to Create a <code>format .dat</code> Entry" on page 474
Automatically configure a SCSI disk	You can automatically configure a SCSI disk with the SCSI-2 specification for disk device mode sense pages even if the specific drive type is not listed in the <code>/etc/format.dat</code> file.	"How to Automatically Configure a SCSI Drive" on page 475
Repair a defective disk sector	Identify a defective disk sector by using the <code>format</code> utility.	"How to Identify a Defective Sector by Using Surface Analysis" on page 477
If necessary, fix a defective disk sector	Fix a defective disk sector by using the <code>format</code> utility.	"How to Repair a Defective Sector" on page 478

Identifying Disks on a System

Use the `format` utility to discover the types of disks that are connected to a system. You can also use the `format` utility to verify that a disk is known to the system. For information on using the `format` utility, see Chapter 36.

▼ How to Identify the Disks on a System

1. **Become superuser or assume an equivalent role.**
2. **Identify the disks that are recognized on the system with the `format` utility.**

```
# format
```

The `format` utility displays a list of disks that it recognizes under `AVAILABLE DISK SELECTIONS`.

Examples—Identifying the Disks on a System

The following `format` output is from a system with one disk.

```
# format
Searching for disks...done

AVAILABLE DISK SELECTIONS:
  0. c0t0d0 <ST34321A cyl 8892 alt 2 hd 15 sec 63>
     /pci@1f,0/pci@1,1/ide@3/dad@0,0
Specify disk (enter its number):
```

The `format` output associates a disk's physical and logical device name to the disk's marketing name, which appears in angle brackets `<>`. See the example below. This method is an easy way to identify which logical device names represent the disks that are connected to your system. For a description of logical and physical device names, see Chapter 30.

The following example uses a wildcard to display the disks that are connected to a second controller.

```
# format /dev/rdisk/c2*
AVAILABLE DISK SELECTIONS:
  0. /dev/rdisk/c2t10d0s0 <SUN9.0G cyl 4924 alt 2 hd 27 sec 133>
     /sbus@3,0/SUNW,fas@3,8800000/sd@a,0
  1. /dev/rdisk/c2t11d0s0 <SUN9.0G cyl 4924 alt 2 hd 27 sec 133>
     /sbus@3,0/SUNW,fas@3,8800000/sd@b,0
  2. /dev/rdisk/c2t14d0s0 <SUN18G cyl 7506 alt 2 hd 19 sec 248>
     /sbus@3,0/SUNW,fas@3,8800000/sd@e,0
  3. /dev/rdisk/c2t15d0s0 <SUN18G cyl 7506 alt 2 hd 19 sec 248>
     /sbus@3,0/SUNW,fas@3,8800000/sd@f,0
Specify disk (enter its number):
```

The following example identifies the disks on a SPARC based system.

```
# format
0. c0t3d0 <SUN2.1G cyl 2733 alt 2 hd 19 sec 80>
   /iommu@0,10000000/sbus@0,10001000/espdma@5,8400000/esp@5,8800000/sd@3,0
Specify disk (enter its number):
```

The `format` output identifies that disk 0 (target 3) is connected to the first SCSI host adapter (`espdma@...`), which is connected to the first SBus device (`sbus@0...`). The output also associates both the physical and logical device name to the disk's marketing name, `SUN2.1G`.

The following example shows how to identify the disks on an x86 based system.

```
# format
AVAILABLE DISK SELECTIONS:
  0. c0d0 <DEFAULT cyl 615 alt 2 hd 64 sec 63>
     /pci@0,0/pci-ide@7,1/ata@0/cmdk@0,0
  1. c0d1 <DEFAULT cyl 522 alt 2 hd 32 sec 63>
     /pci@0,0/pci-ide@7,1/ata@0/cmdk@1,0
```

```
2. c1d0 <DEFAULT cyl 817 alt 2 hd 256 sec 63>
   /pci@0,0/pci-ide@7,1/ata@1/cmdk@0,0
Specify disk (enter its number):
```

The `format` output identifies that disk 0 is connected to the first PCI host adapter (`pci-ide@7...`), which is connected to the ATA device (`ata...`). The `format` output on an x86 based system does not identify disks by their marketing names.

Where to Go From Here

Check the following table if the `format` utility did not recognize a disk.

Disk Problem	To Solve the Problem
Disk is newly added and you didn't perform a reconfiguration boot	Go to Chapter 34 or Chapter 35.
Disk is a third-party disk	Go to "Creating a <code>format.dat</code> Entry" on page 473.
Label was corrupted by a system problem, such as a power failure	Go to "How to Label a Disk" on page 467.
Disk is not properly connected to the system	Connect the disk to the system by using your disk hardware documentation.

Formatting a Disk

Disks are formatted by the manufacturer or reseller. They usually do not need to be reformatted when you install the drive.

A disk must be formatted before you can do the following:

- Write data to it. However, most disks are already formatted.
- Use the Solaris installation program to install the system.



Caution – Formatting a disk is a destructive process because it overwrites data on the disk. For this reason, disks are usually formatted only by the manufacturer or reseller. If you think disk defects are the cause of recurring problems, you can use the `format` utility to do a surface analysis. However, be careful to use only the commands that do not destroy data.

▼ How to Determine if a Disk is Formatted

1. Become superuser or assume an equivalent role.

2. Invoke the `format` utility.

```
# format
```

3. Type the number of the disk that you want to check from the list displayed on your screen.

```
Specify disk (enter its number): 0
```

4. Verify that the disk you chose is formatted by noting the following message.

```
[disk formatted]
```

Example—Determining if a Disk Is Formatted

The following example shows that disk `c1t0d0` is formatted.

```
# format /dev/rdisk/c1*
AVAILABLE DISK SELECTIONS:
  0. /dev/rdisk/c1t0d0s0 <SUN18G cyl 7506 alt 2 hd 19 sec 248>
     /sbus@2,0/QLGC,isp@2,10000/sd@0,0
  1. /dev/rdisk/c1t1d0s0 <SUN18G cyl 7506 alt 2 hd 19 sec 248>
     /sbus@2,0/QLGC,isp@2,10000/sd@1,0
  2. /dev/rdisk/c1t8d0s0 <SUN18G cyl 7506 alt 2 hd 19 sec 248>
     /sbus@2,0/QLGC,isp@2,10000/sd@8,0
  3. /dev/rdisk/c1t9d0s0 <SUN18G cyl 7506 alt 2 hd 19 sec 248>
     /sbus@2,0/QLGC,isp@2,10000/sd@9,0
Specify disk (enter its number): 0
selecting /dev/rdisk/c1t0d0s0
[disk formatted]
```

▼ How to Format a Disk

1. Become superuser or assume an equivalent role.

2. Invoke the `format` utility.

```
# format
```

3. Type the number of the disk that you want to format from the list displayed on your screen.

```
Specify disk (enter its number): 0
```



Caution – Do not select the system disk. If you format your system disk, you delete the operating system and any data on this disk.

4. To begin formatting the disk, type **format** at the **format>** prompt. Confirm the command by typing **y**.

```
format> format
Ready to format. Formatting cannot be interrupted
and takes 23 minutes (estimated). Continue? yes
```

5. Verify that the disk format is successful by noting the following messages.

```
Beginning format. The current time Tue ABC xx xx:xx:xx xxxx

Formatting...
done

Verifying media...
    pass 0 - pattern = 0xc6dec6de
    2035/12/18

    pass 1 - pattern = 0x6db6db6d
    2035/12/18

Total of 0 defective blocks repaired.
```

Example—Formatting a Disk

The following example shows how to format the disk `c0t3d0`.

```
# format
Searching for disks...done
AVAILABLE DISK SELECTIONS:
  0. c0t1d0 <SUN1.05 cyl 2036 alt 2 hd 14 sec 72>
    /iommu@f,e0000000/sbus@f,e0001000/espdma@f,400000/esp@f,800000/sd@1,0
  1. c0t3d0 <SUN1.05 cyl 2036 alt 2 hd 14 sec 72>
    /iommu@f,e0000000/sbus@f,e0001000/espdma@f,400000/esp@f,800000/sd@3,0
Specify disk (enter its number):1
Selecting c0t3d0
[disk formatted]
format> format
Ready to format. Formatting cannot be interrupted
and takes 23 minutes (estimated). Continue? yes
Beginning format. The current time is Thu Dec  6 09:54:40 2001
Formatting ...
done
Verifying media...
    pass 0 - pattern = 0xc6dec6de
    2035/12/18
```



```
pass 1 - pattern = 0x6db6db6d
2035/12/18

Total of 0 defective blocks repaired.
format>
```

Displaying Disk Slices

You can use the `format` utility to check whether a disk has the appropriate disk slices. If you determine that a disk does not contain the slices you want to use, use the `format` utility to re-create them and label the disk. For information on creating disk slices, see “SPARC: How to Create Disk Slices and Label a Disk” on page 484 or “x86: How to Create Disk Slices and Label a Disk” on page 501.

Note – The `format` utility uses the term *partition* instead of *slice*.

▼ How to Display Disk Slice Information

1. Become superuser or assume an equivalent role.
2. Invoke the `format` utility.

```
# format
```
3. Type the number of the disk for which you want to display slice information from the list displayed on your screen.

```
Specify disk (enter its number):1
```
4. Select the partition menu.

```
format> partition
```
5. Display the slice information for the current disk drive.

```
partition> print
```
6. Exit the `format` utility.

```
partition> q
format> q
#
```
7. Verify the displayed slice information by identifying specific slice tags and slices.

If the screen output shows that no slice sizes are assigned, the disk probably does not have slices.

Examples—Displaying Disk Slice Information

The following example displays slice information for disk with a VTOC label.

```
# format
Searching for disks...done
Specify disk (enter its number):1
Selecting c0t0d0
format> partition
partition> print
Current partition table (original):
Total disk cylinders available: 8892 + 2 (reserved cylinders)

Part      Tag      Flag      Cylinders      Size      Blocks
 0      root      wm      1110 - 4687      1.61GB      (0/3578/0) 3381210
 1      swap      wu       0 - 1109      512.00MB      (0/1110/0) 1048950
 2      backup    wm       0 - 8891      4.01GB      (0/8892/0) 8402940
 3 unassigned  wm       0              0              (0/0/0)      0
 4 unassigned  wm       0              0              (0/0/0)      0
 5 unassigned  wm       0              0              (0/0/0)      0
 6 unassigned  wm       0              0              (0/0/0)      0
 7      home      wm      4688 - 8891      1.89GB      (0/4204/0) 3972780
partition> q
format> q
#
```

For a detailed description of the slice information in these examples, see Chapter 32.

The following example shows the slice information on a disk with an EFI label.

```
# format
Searching for disks...done
Specify disk (enter its number): 9
selecting c4t1d0
[disk formatted]
format> partition
partition> print
Current partition table (original):
partition> q
format> q

Part      Tag      Flag      First Sector      Size      Last Sector
 0      root      wm          34      300.00GB      629145633
 1      usr      wm      629145634      300.00GB      1258291233
 2 unassigned  wm          0              0              0
 3 unassigned  wm          0              0              0
 4 unassigned  wm          0              0              0
 5 unassigned  wm          0              0              0
 6      usr      wm      1258291234      628.77GB      2576924637
 8      reserved  wm      2576924638      8.00MB      2576941021
```

Creating and Examining a Disk Label

The labeling of a disk is usually done during system installation or when you are creating new disk slices. You might need to relabel a disk if the disk label becomes corrupted (for example, from a power failure).

The `format` utility attempts to automatically configure any unlabeled SCSI disk. If the `format` utility is able to automatically configure an unlabeled disk, it displays a message like the following:

```
c0t0d1: configured with capacity of 4.00GB
```

Tip – For information on labeling multiple disks with the same disk label, see “Label Multiple Disks by Using the `prtvtoc` and `fmthard` Commands” on page 479.

▼ How to Label a Disk

You can use the following procedure to label a disk with a VTOC label or a disk greater than 1 terabyte with an EFI label. If you want to put an EFI label on a disk smaller than 1 terabyte, see “Example—Labeling a Disk Less Than 1 Terabyte with an EFI Label” on page 469.

1. **Become superuser or assume an equivalent role.**

2. **Invoke the `format` utility.**

```
# format
```

3. **Type the number of the disk that you want to label from the list displayed on your screen.**

```
Specify disk (enter its number):1
```

4. **Select one of the following.**

a. **If the disk is unlabeled and was successfully configured, go to step 5 to label the disk.**

The `format` utility will ask if you want to label the disk.

b. **If the disk is labeled and you want to change the disk type, or if the `format` utility was not able to automatically configure the disk, follow steps 6-7 to set the disk type and label the disk.**

5. **Label the disk by typing `y` at the `Label it now?` prompt.**

```
Disk not labeled. Label it now? y
```

The disk is now labeled. Go to step 10 to exit the format utility.

6. Enter type at the format> prompt.

```
format> type
```

The Available Drive Types menu is displayed.

7. Select a disk type from the list of possible disk types.

```
Specify disk type (enter its number) [12]: 12
```

Or, select 0 to automatically configure a SCSI-2 disk. For more information, see “How to Automatically Configure a SCSI Drive” on page 475.

8. Label the disk. If the disk is not labeled, the following message is displayed.

```
Disk not labeled. Label it now? y
```

Otherwise, you are prompted with this message:

```
Ready to label disk, continue? y
```

9. Verify the disk label.

```
format> verify
```

10. Exit the format utility.

```
partition> q
```

```
format> q
```

```
#
```

Example—Labeling a Disk

The following example shows how to automatically configure and label a 1.05-Gbyte disk.

```
# format
  clt0d0: configured with capacity of 1002.09MB

AVAILABLE DISK SELECTIONS:
  0. c0t3d0 <SUN1.05 cyl 2036 alt 2 hd 14 sec 72>
    /iommu@f,e0000000/sbus@f,e0001000/espdma@f,400000/esp@f,800000/sd@1,0
  1. clt0d0 <SUN1.05 cyl 2036 alt 2 hd 14 sec 72>
    /iommu@f,e0000000/sbus@f,e0001000/espdma@f,400000/esp@f,800000/sd@1,0
Specify disk (enter its number): 1
Disk not labeled. Label it now? yes
format> verify
#
```

Example—Labeling a Disk Less Than 1 Terabyte with an EFI Label

The following example shows how to use the `format -e` command to label a disk less than 1 terabyte with an EFI label. Remember to verify that your layered software products will continue to work on systems with EFI-labeled disks. For general information on EFI label restrictions, see “Restrictions of the EFI Disk Label” on page 441.

```
# format -e
Searching for disks...done
AVAILABLE DISK SELECTIONS:
  1. c1t0d0 <SUNW18g cyl 7506 alt 2 hd 19 sec 248>
     /sbus@2,0/QLGC,isp@2,10000/sd@0,0
  2. c1t1d0 <SUNW18g cyl 7506 alt 2 hd 19 sec 248>
     /sbus@2,0/QLGC,isp@2,10000/sd@1,0
  3. c1t8d0 <SUNW18g cyl 7506 alt 2 hd 19 sec 248>
     /sbus@2,0/QLGC,isp@2,10000/sd@8,0
  4. c1t9d0 <SUNW18g cyl 7506 alt 2 hd 19 sec 248>
     /sbus@2,0/QLGC,isp@2,10000/sd@9,0
Specify disk (enter its number): 4
selecting c1t9d0
[disk formatted]
format> label
[0] SMI Label
[1] EFI Label
Specify Label type[0]: 1
Ready to label disk, continue? yes
format> quit
```

▼ How to Examine a Disk Label

Examine disk label information by using the `prtvtoc` command. For a detailed description of the disk label and the information that is displayed by the `prtvtoc` command, see Chapter 32.

1. Become superuser or assume an equivalent role.
2. Display the disk label information.

```
# prtvtoc /dev/rdisk/device-name
device-name is the raw disk device you want to examine.
```

Examples—Examining a Disk Label

The following example shows the disk label information for disk with a VTOC label.

```
# prtvtoc /dev/rdisk/c0t0d0s0
* /dev/rdisk/c0t0d0s0 partition map
*
```

```

* Dimensions:
*   512 bytes/sector
*   63 sectors/track
*   15 tracks/cylinder
*   945 sectors/cylinder
*   8894 cylinders
*   8892 accessible cylinders
*
* Flags:
*   1: unmountable
*   10: read-only
*
*
* Partition  Tag  Flags      First      Sector      Last
*           Sector  Count      Sector  Count      Sector  Mount Directory
*   0         2    00    1048950  3381210  4430159  /
*   1         3    01         0    1048950  1048949
*   2         5    00         0    8402940  8402939
*   7         8    00    4430160  3972780  8402939  /export/home

```

The following example shows the disk label information for disk with an EFI label.

```

# prtvtoc /dev/rdisk/c3t1d0s0
# /dev/rdisk/c3t1d0s0 partition map
*
* Dimensions:
*   512 bytes/sector
* 2479267840 sectors
* 2479267773 accessible sectors
*
* Flags:
*   1: unmountable
*   10: read-only
*
*
* Partition  Tag  Flags      First      Sector      Last
*           Sector  Count      Sector  Count      Sector  Mount Directory
*   0         2    00         34    262144    262177
*   1         3    01    262178    262144    524321
*   6         4    00    524322 2478727100 2479251421
*   8        11    00 2479251422    16384 2479267805

```

Recovering a Corrupted Disk Label

Sometimes, a power or system failure causes a disk's label to become unrecognizable. A corrupted disk label doesn't always mean that the slice information or the disk's data must be recreated or restored.

The first step to recovering a corrupted disk label is to label the disk with the correct geometry and disk type information. You can complete this step through the normal disk labeling method, by using either automatic configuration or manual disk type specification.

If the `format` utility recognizes the disk type, the next step is to search for a backup label to label the disk. Labeling the disk with the backup label labels the disk with the correct partitioning information, the disk type, and disk geometry.

▼ How to Recover a Corrupted Disk Label

1. Boot the system to single-user mode.

If necessary, boot the system from a local CD-ROM or the network in single-user mode to access the disk.

See Chapter 13 or Chapter 14 for information on booting the system.

2. Relabel the disk.

```
# format
```

At this point, the `format` utility attempts to automatically configure any unlabeled SCSI disk. If the `format` utility is able to configure the unlabeled and corrupted disk, it will display:

```
cwtxdy: configured with capacity of abcMB
```

The `format` utility then displays the list of disks on the system.

3. Type the number of the disk that you need to recover from the list displayed on your screen.

```
Specify disk (enter its number): 1
```

4. Select one of the following to determine how to label the disk.

a. If the disk was configured successfully, follow steps 5 and 6. Then go to step 12.

b. If the disk was not configured successfully, follow steps 7-11. Then go to step 12.

5. Search for the backup label.

```
format> verify
```

```
Warning: Could not read primary label.
```

```
Warning: Check the current partitioning and 'label' the disk or use the 'backup' command.
```

```
Backup label contents:
```

```
Volume name = < >
```

```
ascii name = <SUN1.05 cyl 2036 alt 2 hd 14 sec 72>
```

```
pcyl = 2038
```

```
ncyl = 2036
```

```
acyl = 2
```

```
nhead = 14
```

```
nsect = 72
```

Part	Tag	Flag	Cylinders	Size	Blocks
0	root	wm	0 - 300	148.15MB	(301/0/0) 303408

1	swap	wu	301 - 524	110.25MB	(224/0/0)	225792
2	backup	wm	0 - 2035	1002.09MB	(2036/0/0)	2052288
3	unassigned	wm	0	0	(0/0/0)	0
4	unassigned	wm	0	0	(0/0/0)	0
5	unassigned	wm	0	0	(0/0/0)	0
6	usr	wm	525 - 2035	743.70MB	(1511/0/0)	1523088
7	unassigned	wm	0	0	(0/0/0)	0

6. If the **format** utility was able to find a backup label and the backup label contents appear satisfactory, use the **backup** command to label the disk with the backup label.

```
format> backup
Disk has a primary label, still continue? y
```

```
Searching for backup labels...found.
Restoring primary label
The disk label has been recovered. Go to step 12.
```

7. If the **format** utility was not able to automatically configure the disk, specify the disk type by using the **type** command.

```
format> type
The Available Drives Type menu is displayed.
```

8. Select 0 to automatically configure the disk, or select a disk type from the list of possible disk types.

```
Specify disk type (enter its number) [12]: 12
```

9. If the disk was successfully configured, reply with **no** when the **format** utility asks if you want to label the disk.

```
Disk not labeled. Label it now? no
```

10. Use the **verify** command to search for backup labels.

```
format> verify
Warning: Could not read primary label.
Warning: Check the current partitioning and 'label' the disk
or use the 'backup' command.
.
.
.
```

11. If the **format** utility was able to find a backup label and the backup label contents appear satisfactory, use the **backup** command to label the disk with the backup label.

```
format> backup
Disk has a primary label, still continue? y
Searching for backup labels...found.
Restoring primary label
The disk label has been recovered.
```

12. Exit the `format` utility.

```
format> q
```

13. Verify the file systems on the recovered disk by using the `fsck` command.

For information on using the `fsck` command, see Chapter 43.

Adding a Third-Party Disk

The Solaris environment supports many third-party disks. However, you might need to supply either a device driver, a `format .dat` entry, or both for the disk to be recognized. Other options for adding disks are as follows:

- If you are adding a SCSI disk, you might try the `format` utility's automatic configuration feature. For more information, see "Automatically Configuring SCSI Disk Drives" on page 474.
- You might try hot-plugging a PCI, SCSI, or USB disk. For more information, see Chapter 27.

If the third-party disk is designed to work with standard SunOS-compatible device drivers, then creation of an appropriate `format .dat` entry should be enough to allow the disk to be recognized by the `format` utility. In other cases, you need to load a third-party device driver to support the disk.

Note – Sun cannot guarantee that its `format` utility will work properly with all third-party disk drivers. If the disk driver is not compatible with the Solaris `format` utility, the disk drive vendor should supply you with a custom `format` program.

This section discusses what to do if some of this software support is missing. Typically, you discover that software support is missing when you invoke the `format` utility and find that the disk type is not recognized.

Supply the missing software as described in this section, and then refer to the appropriate configuration procedure for adding system disks or secondary disks in Chapter 34 or Chapter 35.

Creating a `format .dat` Entry

Unrecognized disks cannot be formatted without precise information about the disk's geometry and operating parameters. This information is supplied in the `/etc/format.dat` file.

Note – SCSI-2 drives do not require a `format.dat` entry. The `format` utility automatically configures the SCSI-2 drivers if the drives are powered on during a reconfiguration boot. For step-by-step instructions on configuring a SCSI disk drive automatically, see “How to Automatically Configure a SCSI Drive” on page 475.

If your disk is unrecognized, use a text editor to create an entry in `format.dat` for the disk. You need to gather all the pertinent technical specifications about the disk and its controller before you start. This information should have been provided with the disk. If not, contact the disk manufacturer or your supplier.

▼ How to Create a `format.dat` Entry

1. **Become superuser or assume an equivalent role.**
2. **Make a copy of the `/etc/format.dat` file.**

```
# cp /etc/format.dat /etc/format.dat.gen
```
3. **Modify the `/etc/format.dat` file to include an entry for the third-party disk by using the `format.dat` information that is described in Chapter 36.**

Use the disk’s hardware product documentation to gather the required information.

Automatically Configuring SCSI Disk Drives

The `format` utility automatically configures SCSI disk drives even if that specific type of drive is not listed in the `/etc/format.dat` file. This feature enables you to format, create slices for, and label any disk driver that is compliant with the SCSI-2 specification for disk device mode sense pages.

Other options for adding disks are:

- If you are adding a SCSI disk, you might try the `format` utility’s automatic configuration feature. For more information, see “Automatically Configuring SCSI Disk Drives” on page 474.
- You might try hot-plugging a PCI, SCSI, or USB disk. For more information, see Chapter 27.

The following steps are involved in configuring a SCSI drive by using automatic configuration:

- Shutting down the system
- Attaching the SCSI disk drive to the system
- Turning on the disk drive
- Performing a reconfiguration boot
- Using the `format` utility to automatically configure the SCSI disk drive

After the reconfiguration boot, invoke the `format` utility. The `format` utility will attempt to configure the disk and, if successful, alert the user that the disk was configured. For step-by-step instructions on configuring a SCSI disk drive automatically, see “How to Automatically Configure a SCSI Drive” on page 475.

Here’s an example of a partition table for a 1.3-Gbyte SCSI disk drive that was displayed by the `format` utility.

Part	Tag	Flag	Cylinders	Size	Blocks
0	root	wm	0 - 96	64.41MB	(97/0/0)
1	swap	wu	97 - 289	128.16MB	(193/0/0)
2	backup	wu	0 - 1964	1.27GB	(1965/0/0)
6	usr	wm	290 - 1964	1.09GB	(1675/0/0)

For more information on using SCSI automatic configuration, see Chapter 36.

▼ How to Automatically Configure a SCSI Drive

1. **Become superuser or equivalent role.**
2. **Create the `/reconfigure` file that will be read when the system is booted.**

```
# touch /reconfigure
```

3. **Shut down the system.**

```
# shutdown -i0 -gn -y
```

<code>-i<i>n</i></code>	Brings the system down to init level 0, the power-down state.
<code>-g30</code>	Notifies logged-in users that they have <i>n</i> seconds before the system begins to shut down.
<code>-y</code>	Specifies that the command should run without user intervention.

The `ok` prompt is displayed after the system is shut down.

4. **Turn off the power to the system and all external peripheral devices.**
5. **Make sure that the disk you are adding has a different target number than the other devices on the system.**

You will often find a small switch located at the back of the disk for this purpose.

6. Connect the disk to the system and check the physical connections.

Refer to the disk's hardware installation guide for installation details.

7. Turn on the power to all external peripherals.

8. Turn on the power to the system.

The system boots and displays the login prompt.

9. Log back in as superuser or assume an equivalent role.

10. Invoke the `format` utility and select the disk that you want to configure automatically.

```
# format
Searching for disks...done
c1t0d0: configured with capacity of 1002.09MB
AVAILABLE DISK SELECTIONS:
0. c0t1d0 <SUN1.05 cyl 2036 alt 2 hd 14 sec 72>
   /iommu@f,e0000000/sbus@f,e0001000/espdma@f,400000/esp@f,800000/sd@1,0
1. c0t3d0 <SUN1.05 cyl 2036 alt 2 hd 14 sec 72>
   /iommu@f,e0000000/sbus@f,e0001000/espdma@f,400000/esp@f,800000/sd@3,0
Specify disk (enter its number): 1
```

11. Type `yes` to the prompt to label the disk.

Typing `y` causes the disk label to be generated and written to the disk by SCSI automatic configuration.

```
Disk not labeled. Label it now? y
```

12. Verify the disk label.

```
format> verify
```

13. Exit the `format` utility.

```
format> q
```

Repairing a Defective Sector

If a disk on your system has a defective sector, you can repair it by following procedures in this section. You might become aware of defective sectors when you do the following:

- Run surface analysis on a disk

For more information on the analysis feature of the `format` utility, see “The analyze Menu” on page 510.

The defective area reported while your system is running might not be accurate. Since the system does disk operations many sectors at a time, it is often hard to pinpoint exactly which sector caused a given error. To find the exact sector(s), use “How to Identify a Defective Sector by Using Surface Analysis” on page 477.

- Get multiple error messages from the disk driver concerning a particular portion of the disk while your system is running.

Messages that are related to disk errors look like the following:

```
WARNING: /io-unit@f,e0200000/sbi@0,0/QLGC,isp@1,10000/sd@3,0 (sd33):
  Error for command 'read' Error Level: Retryable
  Requested Block 126, Error Block: 179
  Sense Key: Media Error
  Vendor 'name' :
  ASC = 0x11 (unrecovered read error), ASCQ = 0x0, FRU = 0x0
```

The preceding console message indicates that block 179 might be defective. Relocate the bad block by using the `format` utility's `repair` command or use the `analyze` command with the `repair` option enabled.

▼ How to Identify a Defective Sector by Using Surface Analysis

1. Become superuser or assume an equivalent role.
2. Unmount the file system in the slice that contains the defective sector.

```
# umount /dev/dsk/device-name
For more information, see mount(1M).
```

3. Invoke the `format` utility.

```
# format
```

4. Select the affected disk.

```
Specify disk (enter its number):1
selecting c0t2d0:
[disk formatted]
Warning: Current Disk has mounted partitions.
```

5. Select the `analyze` menu.

```
format> analyze
```

6. Set up the analysis parameters by typing `setup` at the `analyze>` prompt.

Use the parameters shown here:

```
analyze> setup
Analyze entire disk [yes]? n
Enter starting block number [0, 0/0/0]: 12330
```

```

Enter ending block number [2052287, 2035/13/71]: 12360
Loop continuously [no]? y
Repair defective blocks [yes]? n
Stop after first error [no]? n
Use random bit patterns [no]? n
Enter number of blocks per transfer [126, 0/1/54]: 1
Verify media after formatting [yes]? y
Enable extended messages [no]? n
Restore defect list [yes]? y
Create defect label [yes]? y

```

7. Use the read command to find the defect.

```

analyze> read
Ready to analyze (won't harm SunOS). This takes a long time,
but is interruptible with Control-C. Continue? y
    pass 0
    2035/12/1825/7/24
    pass 1
Block 12354 (18/4/18), Corrected media error (hard data ecc)
    25/7/24
^C
Total of 1 defective blocks repaired.

```

▼ How to Repair a Defective Sector

1. Become superuser or assume an equivalent role.

2. Invoke the format utility.

```
# format
```

3. Select the disk that contains the defective sector.

```
Specify disk (enter its number): 1
selecting c0t3d0
[disk formatted]
format>

```

4. Select the repair command.

```
format> repair
```

5. Type the defective block number.

```
Enter absolute block number of defect: 12354
Ready to repair defect, continue? y
Repairing block 12354 (18/4/18)...ok.
format>

```

If you are unsure of the format that is used to identify the defective sector, see “How to Identify a Defective Sector by Using Surface Analysis” on page 477 for more information.

Tips and Tricks for Managing Disks

Use the following tips to help you manage disks more efficiently.

Debugging format Sessions

Invoke `format -M` to enable extended and diagnostic messages for ATA and SCSI devices.

In this example, the series of numbers under `Inquiry:` represent the hexadecimal value of the inquiry data that is displayed to the right of the numbers.

```
# format -M
Searching for disks...done
AVAILABLE DISK SELECTIONS:
  0. c0t1d0 <SUN1.05 cyl 2036 alt 2 hd 14 sec 72>
     /iommu@f,e0000000/sbus@f,e0001000/espdma@f,400000/esp@f,800000/sd@1,0
  1. c0t3d0 <SUN1.05 cyl 2036 alt 2 hd 14 sec 72>
     /iommu@f,e0000000/sbus@f,e0001000/espdma@f,400000/esp@f,800000/sd@3,0

Specify disk (enter its number): 0
selecting c0t3d0
[disk formatted]
format> inquiry
Inquiry:
00 00 02 02 8f 00 00 12 53 45 41 47 41 54 45 20      .....NAME....
53 54 31 31 32 30 30 4e 20 53 55 4e 31 2e 30 35      ST11200N SUN1.05
38 33 35 38 30 30 30 33 30 32 30 39 00 00 00 00      835800030209....
00 00 00 00 00 00 00 00 00 00 00 00 00 00 00 00      .....
00 00 00 00 00 00 00 00 00 00 00 00 00 00 00 00      .....
00 00 00 00 00 00 00 00 00 00 00 00 00 00 00 00      .....
00 43 6f 70 79 72 69 67 68 74 20 28 63 29 20 31      .Copyright (c) 1
39 39 32 20 53 65 61 67 61 74 65 20 41 6c 6c 20      992 NAME      All
72 69 67 68 74 73 20 72 65 73 65 72 76 65 64 20      rights reserved
30 30 30                                             000
Vendor:      name
Product:     ST11200N SUN1.05
Revision:    8358
format>
```

Label Multiple Disks by Using the `prtvtoc` and `fmthard` Commands

Use the `prtvtoc` and `fmthard` commands to label multiple disks with the same disk geometry.

Use the following `for` loop in a script to copy a disk label from one disk and replicate it on multiple disks.

```
# for i in xyz
> do
> prtvtoc /dev/rdisk/cwtxdysz | fmthard -s - /dev/rdisk/cwt${i}d0s2
> done
```

Example—Labeling Multiple Disks

In this example, the disk label from `c2t0d0s0` is copied to four other disks.

```
# for i in 1 2 3 5
> do
> prtvtoc /dev/rdisk/c2t0d0s0 | fmthard -s - /dev/rdisk/c2t${i}d0s2
> done
fmthard: New volume table of contents now in place.
fmthard: New volume table of contents now in place.
fmthard: New volume table of contents now in place.
fmthard: New volume table of contents now in place.
#
```

SPARC: Adding a Disk (Tasks)

This chapter describes how to add a disk to a SPARC based system.

For information on the procedures associated with adding a disk to a SPARC based system, see “SPARC: Adding a System Disk or a Secondary Disk (Task Map)” on page 481.

For overview information about disk management, see Chapter 32. For step-by-step instructions on adding a disk to an x86 based system, see Chapter 35.

SPARC: Adding a System Disk or a Secondary Disk (Task Map)

The following task map identifies the procedures for adding a disk to a SPARC based system.

Task	Description	For Instructions
1. Connect the disk and boot	<i>System Disk</i> Connect the new disk and boot from a local or remote Solaris CD or DVD.	“SPARC: How to Connect a System Disk and Boot” on page 483

Task	Description	For Instructions
	<p><i>Secondary Disk</i></p> <p>Connect the new disk and perform a reconfiguration boot so that the system will recognize the disk.</p>	<p>“SPARC: How to Connect a Secondary Disk and Boot” on page 483</p>
2. Create slices and label the disk	<p>Create disk slices and label the disk if the disk manufacturer has not already done so.</p>	<p>“SPARC: How to Create Disk Slices and Label a Disk” on page 484</p>
3. Create file systems	<p>Create UFS file systems on the disk slices with the <code>newfs</code> command. You must create the root (/) or /usr file system, or both, for a system disk.</p>	<p>“SPARC: How to Create File Systems” on page 489</p>
4. Restore file systems	<p>Restore the root (/) or /usr file system, or both, on the system disk. If necessary, restore file systems on the secondary disk.</p>	<p>Chapter 49</p>
5. Install boot block	<p><i>System Disk Only.</i> Install the boot block on the root (/) file system, so that the system can boot.</p>	<p>“SPARC: How to Install a Boot Block on a System Disk” on page 490</p>

SPARC: Adding a System Disk or a Secondary Disk

A system disk contains the root (/) or /usr file systems, or both. If the disk that contains either of these file systems becomes damaged, you have two ways to recover:

- You can reinstall the entire Solaris environment.
- Or, you can replace the system disk and restore your file systems from a backup medium.

A secondary disk does not contain the root (/) and /usr file systems. A secondary disk usually contains space for user files. You can add a secondary disk to a system for more disk space, or you can replace a damaged secondary disk. If you replace a secondary disk on a system, you can restore the old disk's data on the new disk.

▼ SPARC: How to Connect a System Disk and Boot

This procedure assumes that the system is shut down.

1. **Disconnect the damaged system disk from the system.**
2. **Make sure that the disk you are adding has a different target number than the other devices on the system.**
You will often find a small switch located at the back of the disk for this purpose.
3. **Connect the replacement system disk to the system and check the physical connections.**
Refer to the disk's hardware installation guide for installation details.
4. **Follow the instructions in the following table, depending on whether you are booting from a local Solaris CD or DVD or a remote Solaris CD or DVD from the network.**

Boot Type	Action
From a Solaris CD or DVD in a local drive	1. Make sure the CD or DVD is in the drive. 2. Boot from the media to single-user mode: <code>ok boot cdrom -s</code>
From the network	Boot from the network to single-user mode: <code>ok boot net -s</code>

After a few minutes, the root prompt (#) is displayed.

Where to Go From Here

After you boot the system, you can create slices and a disk label on the disk. Go to "SPARC: How to Create Disk Slices and Label a Disk" on page 484.

▼ SPARC: How to Connect a Secondary Disk and Boot

1. **Become superuser or assume an equivalent role.**
2. **If the disk type is unsupported by the Solaris software, add the device driver for the disk by following the instructions included with the hardware.**
For information on creating a `format . dat` entry for the disk, see "How to Create a `format . dat` Entry" on page 474, if necessary.

3. Create the `/reconfigure` file that will be read when the system is booted.

```
# touch /reconfigure
```

The `/reconfigure` file causes the SunOS software to check for the presence of any newly installed peripheral devices when you power on or boot your system later.

4. Shut down the system.

```
# shutdown -i0 -gn -y
```

<code>-i0</code>	Changes to run level 0, the power-down state.
<code>-gn</code>	Notifies logged-in users that they have <i>n</i> seconds before the system begins to shut down.
<code>-y</code>	Specifies that the command should run without user intervention.

The `ok` prompt is displayed after the operating environment is shut down.

5. Turn off the power to the system and all external peripheral devices.

6. Make sure that the disk you are adding has a different target number than the other devices on the system.

You will often find a small switch located at the back of the disk for this purpose.

7. Connect the disk to the system and check the physical connections.

Refer to the disk's hardware installation guide for installation details.

8. Turn on the power to all external peripherals.

9. Turn on the power to the system.

The system boots and displays the login prompt.

Where to Go From Here

After you boot the system, you can create slices and a disk label on the disk. Go to "SPARC: How to Create Disk Slices and Label a Disk" on page 484.

▼ SPARC: How to Create Disk Slices and Label a Disk

1. Become superuser or assume an equivalent role.

2. Invoke the `format` utility.

```
# format
```

A list of available disks is displayed. For more information, see `format(1M)`.

3. **Type the number of the disk that you want to repartition from the list displayed on your screen.**

Specify disk (enter its number): *disk-number*

disk-number is the number of the disk that you want to repartition.

4. **Select the partition menu.**

```
format> partition
```

5. **Display the current partition (slice) table.**

```
partition> print
```

6. **Start the modification process.**

```
partition> modify
```

7. **Set the disk to all free hog.**

Choose base (enter number) [0]? 1

For more information about the free hog slice, see “Using the Free Hog Slice” on page 457.

8. **Create a new partition table by answering y when prompted to continue.**

Do you wish to continue creating a new partition table based on above table[yes]? y

9. **Identify the free hog partition (slice) and the sizes of the slices when prompted.**

When adding a system disk, you must set up slices for:

- root (slice 0) and swap (slice 1)
- /usr (slice 6)

After you identify the slices, the new partition table is displayed.

For an example of creating disk slices, see “SPARC: Example—Creating Disk Slices and Labeling a System Disk” on page 486.

10. **Make the displayed partition table the current partition table by answering y when asked.**

Okay to make this the current partition table[yes]? y

If you do not want the current partition table and you want to change it, answer no and go to Step 6.

11. **Name the partition table.**

Enter table name (remember quotes): "*partition-name*"

partition-name is the name for the new partition table.

12. Label the disk with the new partition table after you have finished allocating slices on the new disk.

```
Ready to label disk, continue? yes
```

13. Quit the partition menu.

```
partition> q
```

14. Verify the disk label.

```
format> verify
```

15. Exit the format menu.

```
format> q
```

SPARC: Example—Creating Disk Slices and Labeling a System Disk

The following example shows the `format` utility being used to divide a 18-Gbyte disk into three slices: one slice for the root (`/`) file system, one slice for the swap area, and one slice for the `/usr` file system.

```
# format
AVAILABLE DISK SELECTIONS:
  0. /dev/rdisk/clt0d0s0 <SUN18G cyl 7506 alt 2 hd 19 sec 248>
    /sbus@2,0/QLGC,isp@2,10000/sd@0,0
  1. /dev/rdisk/clt1d0s0 <SUN18G cyl 7506 alt 2 hd 19 sec 248>
    /sbus@2,0/QLGC,isp@2,10000/sd@1,0
  2. /dev/rdisk/clt8d0s0 <SUN18G cyl 7506 alt 2 hd 19 sec 248>
    /sbus@2,0/QLGC,isp@2,10000/sd@8,0
  3. /dev/rdisk/clt9d0s0 <SUN18G cyl 7506 alt 2 hd 19 sec 248>
    /sbus@2,0/QLGC,isp@2,10000/sd@9,0
Specify disk (enter its number): 0
selecting clt0d0
[disk formatted]
format> partition
partition> print
partition> modify
Select partitioning base:
  0. Current partition table (original)
  1. All Free Hog
Part    Tag    Flag    Cylinders    Size    Blocks
  0     root    wm        0            0    (0/0/0)      0
  1     swap    wu        0            0    (0/0/0)      0
  2  backup    wu    0 - 7505    16.86GB    (7506/0/0) 35368272
  3 unassigned    wm        0            0    (0/0/0)      0
  4 unassigned    wm        0            0    (0/0/0)      0
  5 unassigned    wm        0            0    (0/0/0)      0
  6      usr    wm        0            0    (0/0/0)      0
  7 unassigned    wm        0            0    (0/0/0)      0
```

```

Choose base (enter number) [0]? 1
table based on above table[yes]? yes
Free Hog partition[6]? 6
Enter size of partition '0' [0b, 0c, 0.00mb, 0.00gb]: 4gb
Enter size of partition '1' [0b, 0c, 0.00mb, 0.00gb]: 4gb
Enter size of partition '3' [0b, 0c, 0.00mb, 0.00gb]:
Enter size of partition '4' [0b, 0c, 0.00mb, 0.00gb]:
Enter size of partition '5' [0b, 0c, 0.00mb, 0.00gb]:
Enter size of partition '7' [0b, 0c, 0.00mb, 0.00gb]:
Part      Tag      Flag      Cylinders      Size      Blocks
  0      root      wm        0 - 1780      4.00GB    (1781/0/0) 8392072
  1      swap      wu       1781 - 3561    4.00GB    (1781/0/0) 8392072
  2      backup     wu        0 - 7505     16.86GB   (7506/0/0) 35368272
  3 unassigned  wm         0              0          (0/0/0)      0
  4 unassigned  wm         0              0          (0/0/0)      0
  5 unassigned  wm         0              0          (0/0/0)      0
  6      usr       wm       3562 - 7505    8.86GB   (3944/0/0) 18584128
  7 unassigned  wm         0              0          (0/0/0)      0

Okay to make this the current partition table[yes]? yes
Enter table name (remember quotes): "disk0"
Ready to label disk, continue? yes
partition> quit
format> verify
format> quit

```

SPARC: Examples—Creating Disk Slices and Labeling a Secondary Disk

The following example shows the `format` utility being used to divide a 18-Gbyte disk into one slice for the `/export/home` file system.

```

# format /dev/rdisk/c1*
AVAILABLE DISK SELECTIONS:
  0. /dev/rdisk/c1t0d0s0 <SUN18G cyl 7506 alt 2 hd 19 sec 248>
     /sbus@2,0/QLGC,isp@2,10000/sd@0,0
  1. /dev/rdisk/c1t1d0s0 <SUN18G cyl 7506 alt 2 hd 19 sec 248>
     /sbus@2,0/QLGC,isp@2,10000/sd@1,0
  2. /dev/rdisk/c1t8d0s0 <SUN18G cyl 7506 alt 2 hd 19 sec 248>
     /sbus@2,0/QLGC,isp@2,10000/sd@8,0
  3. /dev/rdisk/c1t9d0s0 <SUN18G cyl 7506 alt 2 hd 19 sec 248>
     /sbus@2,0/QLGC,isp@2,10000/sd@9,0

Specify disk (enter its number): 1
selecting c1t1d0
[disk formatted]
format> partition
partition> print
partition> modify
Select partitioning base:
  0. Current partition table (original)
  1. All Free Hog
Choose base (enter number) [0]? 1

```

Part	Tag	Flag	Cylinders	Size	Blocks
0	root	wm	0	0	(0/0/0) 0
1	swap	wu	0	0	(0/0/0) 0
2	backup	wu	0 - 7505	16.86GB	(7506/0/0) 35368272
3	unassigned	wm	0	0	(0/0/0) 0
4	unassigned	wm	0	0	(0/0/0) 0
5	unassigned	wm	0	0	(0/0/0) 0
6	usr	wm	0	0	(0/0/0) 0
7	unassigned	wm	0	0	(0/0/0) 0

Do you wish to continue creating a new partition table based on above table[yes]? **y**

Free Hog partition[6]? **7**

Enter size of partition '0' [0b, 0c, 0.00mb, 0.00gb]:

Enter size of partition '1' [0b, 0c, 0.00mb, 0.00gb]:

Enter size of partition '3' [0b, 0c, 0.00mb, 0.00gb]:

Enter size of partition '4' [0b, 0c, 0.00mb, 0.00gb]:

Enter size of partition '5' [0b, 0c, 0.00mb, 0.00gb]:

Enter size of partition '6' [0b, 0c, 0.00mb, 0.00gb]:

Part	Tag	Flag	Cylinders	Size	Blocks
0	root	wm	0	0	(0/0/0) 0
1	swap	wu	0	0	(0/0/0) 0
2	backup	wu	0 - 7505	16.86GB	(7506/0/0) 35368272
3	unassigned	wm	0	0	(0/0/0) 0
4	unassigned	wm	0	0	(0/0/0) 0
5	unassigned	wm	0	0	(0/0/0) 0
6	usr	wm	0	0	(0/0/0) 0
7	unassigned	wm	0 - 7505	16.86GB	(7506/0/0) 35368272

Okay to make this the current partition table[yes]? **yes**

Enter table name (remember quotes): **"home"**

Ready to label disk, continue? **y**

partition> **q**

format> **verify**

format> **q**

#

The following example shows how to use the format utility to divide a 1.15 terabyte disk with an EFI label into 3 slices.

format

.

.

.

partition> **modify**

Select partitioning base:

0. Current partition table (original)

1. All Free Hog

Choose base (enter number) [0]? **1**

Part	Tag	Flag	First Sector	Size	Last Sector
0	root	wm	0	0	0
1	usr	wm	0	0	0
2	unassigned	wm	0	0	0
3	unassigned	wm	0	0	0
4	unassigned	wm	0	0	0
5	unassigned	wm	0	0	0

```

6      usr      wm          0          0          0
8  reserved  wm      2576924638      8.00MB      2576941021
Do you wish to continue creating a new partition
table based on above table[yes]? y
Free Hog partition[6]? 4
Enter size of partition 0 [0b, 34e, 0mb, 0gb, 0tb]:
Enter size of partition 1 [0b, 34e, 0mb, 0gb, 0tb]:
Enter size of partition 2 [0b, 34e, 0mb, 0gb, 0tb]: 400gb
Enter size of partition 3 [0b, 838860834e, 0mb, 0gb, 0tb]: 400gb
Enter size of partition 5 [0b, 1677721634e, 0mb, 0gb, 0tb]:
Enter size of partition 6 [0b, 1677721634e, 0mb, 0gb, 0tb]:
Part      Tag      Flag      First Sector      Size      Last Sector
0 unassigned  wm          0          0          0
1 unassigned  wm          0          0          0
2      usr      wm          34          400.00GB      838860833
3      usr      wm      838860834          400.00GB      1677721633
4      usr      wm      1677721634          428.77GB      2576924637
5 unassigned  wm          0          0          0
6 unassigned  wm          0          0          0
8  reserved  wm      2576924638      8.00MB      2576941021
Ready to label disk, continue? yes

partition> q

```

Where to Go From Here

After you create disk slices and label the disk, you can create file systems on the disk. Go to “SPARC: How to Create File Systems” on page 489.

▼ SPARC: How to Create File Systems

1. **Become superuser or assume an equivalent role.**

2. **Create a file system for each slice.**

```
# newfs /dev/rdisk/cwtxdysz
```

/dev/rdisk/cwtxdysx is the raw device for the file system to be created.

For more information about the `newfs` command, see Chapter 39 or `newfs(1M)`.

3. **Verify the new file system by mounting.**

```
# mount /dev/dsk/cwtxdysz /mnt
```

```
# ls lost+found
```

SPARC: Where to Go From Here

Add Disk Task	Action
System Disk	<p>You need to restore the root (/) and /usr file systems on the disk. Go to Chapter 49.</p> <p>After the root (/) and /usr file systems are restored, install the boot block. Go to “SPARC: How to Install a Boot Block on a System Disk” on page 490.</p>
Secondary Disk	<p>You might need to restore file systems on the new disk. Go to Chapter 49.</p> <p>If you are not restoring file systems on the new disk, you are finished adding a secondary disk. See Chapter 40 for information on making the file systems available to users.</p>

▼ SPARC: How to Install a Boot Block on a System Disk

1. Become superuser or assume an equivalent role.
2. Install a boot block on the system disk.

```
# installboot /usr/platform/`uname -i`/lib/fs/ufs/bootblk /dev/rdisk/cwtxdys0
```

<code>/usr/platform/`uname -i`/lib/fs/ufs/bootblk</code>	Is the boot block code.
<code>/dev/rdisk/cwtxdys0</code>	Is the raw device of the root (/) file system.

For more information, see `installboot(1M)`.

3. Verify that the boot blocks are installed by rebooting the system to run level 3.

```
# init 6
```

SPARC: Example—Installing a Boot Block on a System Disk

The following example shows how to install the boot block on an Ultra10 system.

```
# installboot /usr/platform/sun4u/lib/fs/ufs/bootblk /dev/rdisk/c0t0d0s0
```

x86: Adding a Disk (Tasks)

This chapter describes how to add a disk to an x86 based system.

For information on the procedures associated with adding a disk to an x86 based system, see “x86: Adding a System Disk or a Secondary Disk (Task Map)” on page 491.

For overview information about disk management, see Chapter 32. For step-by-step instructions on adding a disk to a SPARC based system, see Chapter 34.

x86: Adding a System Disk or a Secondary Disk (Task Map)

Task	Description	For Instructions
1. Connect the disk and boot	<p><i>System Disk</i></p> <p>Connect the new disk and boot from a local or remote Solaris CD or DVD.</p> <p><i>Secondary Disk</i></p> <p>Connect the new disk and perform a reconfiguration boot, so that the system will recognize the disk.</p>	<p>“x86: How to Connect a System Disk and Boot” on page 492</p> <p>“x86: How to Connect a Secondary Disk and Boot” on page 493</p>

Task	Description	For Instructions
2. Create slices and label the disk	Create disk slices and label the disk if the disk manufacturer has not already done so.	"x86: How to Create a Solaris <code>fdisk</code> Partition" on page 495 and "x86: How to Create Disk Slices and Label a Disk" on page 501
3. Create File Systems	Create UFS file systems on the disk slices with the <code>newfs</code> command. You must create the root (/) or <code>/usr</code> file system (or both) for a system disk.	"x86: How to Create File Systems" on page 502
4. Restore File Systems	Restore the root (/) or <code>/usr</code> file system (or both) on the system disk. If necessary, restore file systems on the secondary disk.	Chapter 49
5. Install Boot Block	<i>System Disk Only.</i> Install the boot block on the root (/) file system so that the system can boot.	"x86: How to Install a Boot Block on a System Disk" on page 503

x86: Adding a System or Secondary Disk

A system disk contains the root (/) or `/usr` file systems, or both. If the disk that contains either of these file systems becomes damaged, you have two ways to recover:

- You can reinstall the entire Solaris environment.
- Or, you can replace the system disk and restore your file systems from a backup medium.

A secondary disk doesn't contain the root (/) and `/usr` file systems. A secondary disk usually contains space for user files. You can add a secondary disk to a system for more disk space, or you can replace a damaged secondary disk. If you replace a secondary disk on a system, you can restore the old disk's data on the new disk.

▼ x86: How to Connect a System Disk and Boot

This procedure assumes that the system is down.

1. **Disconnect the damaged system disk from the system.**

2. **Make sure that the disk you are adding has a different target number than the other devices on the system.**

You will often find a small switch located at the back of the disk for this purpose.

3. **Connect the replacement system disk to the system and check the physical connections.**

Refer to the disk's hardware installation guide for installation details.

4. **Follow steps a-e if you are booting from a local Solaris CD or DVD or a remote Solaris CD or DVD from the network.**

If you are booting from the network, skip step a.

- a. **If you are booting from a local Solaris CD or DVD, insert the Solaris installation CD or DVD into the drive.**
- b. **Insert the Solaris boot diskette into the primary diskette drive (DOS drive A).**
- c. **Press any key to reboot the system if the system displays the `Type any key to continue` prompt. Or, use the reset button to restart the system if the system is shut down.**

The Boot Solaris screen is displayed after a few minutes.

- d. **Select the CD-ROM drive or net(work) as the boot device from the Boot Solaris screen.**

The Current Boot Parameters screen is displayed.

- e. **Boot the system in single-user mode.**

Select the type of installation: `b -s`

After a few minutes, the root prompt (`#`) is displayed.

x86: Where to Go From Here

After you boot the system, you can create an `fdisk` partition. Go to "x86: How to Create a Solaris `fdisk` Partition" on page 495.

▼ x86: How to Connect a Secondary Disk and Boot

1. **Become superuser or assume an equivalent role.**
2. **If the disk is unsupported by the Solaris software, add the device driver for the disk by following the instructions included with the hardware.**
3. **Create the `/reconfigure` file that will be read when the system is booted.**

```
# touch /reconfigure
```

The `/reconfigure` file causes the SunOS software to check for the presence of any newly installed peripheral devices when you power on or boot your system later.

4. Shut down the system.

```
# shutdown -i0 -gn -y
```

<code>-i0</code>	Brings the system down to run level 0, the power-down state.
<code>-gn</code>	Notifies logged-in users that they have <i>n</i> seconds before the system begins to shut down.
<code>-y</code>	Specifies that the command should run without user intervention.

The `Type any key to continue` prompt is displayed.

5. Turn off the power to the system and all external peripheral devices.

6. Make sure that the disk you are adding has a different target number than the other devices on the system.

You will often find a small switch located at the back of the disk for this purpose.

7. Connect the disk to the system and check the physical connections.

Refer to the disk's hardware installation guide for installation details.

8. Turn on the power to all external peripherals.

9. Turn on the power to the system.

The system boots and displays the login prompt.

x86: Where to Go From Here

After you boot the system, you can create an `fdisk` partition. Go to "x86: How to Create a Solaris `fdisk` Partition" on page 495.

x86: Guidelines for Creating an `fdisk` Partition

Follow these guidelines when you set up the `fdisk` partition.

- The disk can be divided into a maximum of four `fdisk` partitions. One of partitions must be a Solaris partition.
- The Solaris partition must be made the active partition on the disk. The active partition is partition whose operating system will be booted by default at system startup.

- Solaris `fdisk` partitions must begin on cylinder boundaries.
- Solaris `fdisk` partitions must begin at cylinder 1, not cylinder 0, on the first disk because additional boot information, including the master boot record, is written in sector 0.
- The Solaris `fdisk` partition can be the entire disk or you might want to make it smaller to allow room for a DOS partition. You can also make a new `fdisk` partition on a disk without disturbing existing partitions (if there is enough room to create a new one).

x86 only – Solaris slices are sometimes called partitions. This book uses the term slice, but some Solaris documentation and programs might refer to a *slice* as a *partition*.

To avoid confusion, Solaris documentation tries to distinguish between `fdisk` partitions (which are supported only on Solaris (x86 Platform Edition)) and the divisions within the Solaris `fdisk` partition, which might be called slices or partitions.

▼ x86: How to Create a Solaris `fdisk` Partition

1. Read “x86: Guidelines for Creating an `fdisk` Partition” on page 494.
2. Become superuser or assume an equivalent role.
3. Invoke the `format` utility.

```
# format
```

For more information, see `format(1M)`.

4. Type the number of the disk on which to create a Solaris `fdisk` partition from the list displayed on your screen.

```
Specify disk (enter its number): disk-number
```

disk-number is the number of the disk on which you want to create a Solaris `fdisk` partition.

5. Select the `fdisk` menu.

```
format> fdisk
```

The `fdisk` menu that is displayed depends upon whether the disk has existing `fdisk` partitions. Determine the next step using the following table.

Task	Go To	For More Information
Create a Solaris <code>fdisk</code> partition to span the entire disk.	Step 6	"x86: Example—Creating a Solaris <code>fdisk</code> Partition That Spans the Entire Drive" on page 498
Create a Solaris <code>fdisk</code> partition and preserve one or more existing non-Solaris <code>fdisk</code> partition.	Step 7	"x86: Example—Creating a Solaris <code>fdisk</code> Partition While Preserving an Existing <code>fdisk</code> Partition" on page 498
Create a Solaris <code>fdisk</code> partition and one or more additional non-Solaris <code>fdisk</code> partition.	Step 7	"x86: Example—Creating a Solaris <code>fdisk</code> Partition and an Additional <code>fdisk</code> Partition" on page 499

6. Create and activate a Solaris `fdisk` partition that spans the entire disk by specifying `y` at the prompt. Then, go to step 14.

The recommended default partitioning for your disk is:

```
a 100% "SOLARIS System" partition.
```

To select this, please type "y". To partition your disk differently, type "n" and the "fdisk" program will let you select other partitions. **y**

7. Specify `n` at the prompt if you do not want the Solaris `fdisk` partition to span the entire disk.

To select this, please type "n". To partition your disk differently, type "n" and the "fdisk" program will let you select other partitions. **n**

```
Total disk size is 2694 cylinders
```

```
    Cylinder size is 765 (512 byte) blocks
```

```

                                     Cylinders
Partition  Status  Type      Start  End  Length  %
=====  =====  =====  =====  ===  =====  ==
```

```
THERE ARE NO PARTITIONS CURRENTLY DEFINED SELECT ONE OF THE
FOLLOWING:
```

1. Create a partition
2. Change Active (Boot from) partition
3. Delete a partition
4. Exit (Update disk configuration and exit)
5. Cancel (Exit without updating disk configuration)

```
Enter Selection:
```

8. Select option 1, Create a partition, to create an `fdisk` partition.

```
Total disk size is 2694 cylinders
```

```
Cylinder size is 765 (512 byte) blocks
```

```
                                     Cylinders
```



```

Partition  Status  Type      Start  End  Length  %
=====  =====  =====  =====  ===  =====  ==

```

THERE ARE NO PARTITIONS CURRENTLY DEFINED SELECT ONE OF THE FOLLOWING:

1. Create a partition
2. Change Active (Boot from) partition
3. Delete a partition
4. Exit (Update disk configuration and exit)
5. Cancel (Exit without updating disk configuration)

Enter Selection: 1

9. Create a Solaris fdisk partition by selecting 1 (=Solaris).

Indicate the type of partition you want to create
 (1=SOLARIS, 2=UNIX, 3=PCIXOS, 4=Other, 8=DOSBIG)
 (5=DOS12, 6=DOS16, 7=DOSEXT, 0=Exit) ? 1

10. Identify the percentage of the disk to be reserved for the Solaris fdisk partition. Keep in mind the size of any existing fdisk partitions when you calculate this percentage.

Indicate the percentage of the disk you want this partition to use (or enter "c" to specify in cylinders). *mm*

11. Activate the Solaris fdisk partition by typing y at the prompt.

Do you want this to become the Active partition? If so, it will be activated each time you reset your computer or when you turn it on again. Please type "y" or "n". **y**

The Enter Selection: prompt is displayed after the fdisk partition is activated.

12. Select option 1, Create a partition, to create another fdisk partition.

See steps 9-11 for instructions on creating an fdisk partition.

13. Update the disk configuration and exit the fdisk menu from the selection menu.

Selection: 4

14. Relabel the disk by using the label command.

```

WARNING: Solaris fdisk partition changed - Please relabel the disk
format> label
Ready to label disk, continue? yes
format>

```

15. Quit the format menu.

```
format> quit
```

x86: Where to Go From Here

After you create a Solaris `fdisk` partition on the disk, you can create slices on the disk. Go to “x86: How to Create Disk Slices and Label a Disk” on page 501.

x86: Example—Creating a Solaris `fdisk` Partition That Spans the Entire Drive

The following example uses the `format`'s utility's `fdisk` option to create a Solaris `fdisk` partition that spans the entire drive.

```
# format
Searching for disks...done
AVAILABLE DISK SELECTIONS:
    0. c0d0 <DEFAULT cyl 2466 alt 2 hd 16 sec 63>
        /pci@0,0/pci-ide@7,1/ide@0/cmdk@0,0
    1. c0d1 <DEFAULT cyl 522 alt 2 hd 32 sec 63>
        /pci@0,0/pci-ide@7,1/ide@0/cmdk@1,0
    2. c1d0 <DEFAULT cyl 13102 alt 2 hd 16 sec 63>
        /pci@0,0/pci-ide@7,1/ide@1/cmdk@0,0
Specify disk (enter its number): 0
selecting c0d0
Controller working list found
[disk formatted]
format> fdisk
The recommended default partitioning for your disk is:

    a 100% "SOLARIS System" partition.

To select this, please type "y". To partition your disk
differently, type "n" and the "fdisk" program will let you
select other partitions. y

WARNING: Solaris fdisk partition changed - Please relabel the disk
format> label
Ready to label disk, continue? yes
format> quit
```

x86: Example—Creating a Solaris `fdisk` Partition While Preserving an Existing `fdisk` Partition

The following example shows how to create a Solaris `fdisk` partition on a disk that has an existing DOS-BIG `fdisk` partition.

```
format> fdisk
Total disk size is 2694 cylinders
Cylinder size is 765 (512 byte) blocks
Cylinders
Partition  Status  Type      Start  End  Length  %
=====  =====  =====  =====  ===  =====  ==
```

```

          1                DOS-BIG          1  538      538  20
SELECT ONE OF THE FOLLOWING:
  1.  Create a partition
  2.  Change Active (Boot from) partition
  3.  Delete a partition
  4.  Exit (Update disk configuration and exit)
  5.  Cancel (Exit without updating disk configuration)
Enter Selection: 1
Indicate the type of partition you want to create
(1=SOLARIS, 2=UNIX, 3=PCIXOS, 4=Other, 8=DOSBIG)
(5=DOS12, 6=DOS16, 7=DOSEXT, 0=Exit) ?1
Indicate the percentage of the disk you want this partition
to use (or enter "c" to specify in cylinders). 80
Do you want this to become the Active partition? If so, it will be
activated each time you reset your computer or when you turn it on
again. Please type "y" or "n". y
Partition 2 is now the Active partition Total disk size is 2694
cylinders

          Cylinder size is 765 (512 byte) blocks
                                Cylinders
Partition  Status   Type      Start  End  Length  %
=====  =====  =====  =====  ===  =====  ==
          1                DOS-BIG          1  538      538  20
          2      Active   SOLARIS      539 2693     2155  80
SELECT ONE OF THE FOLLOWING:
  1.  Create a partition
  2.  Change Active (Boot from) partition
  3.  Delete a partition
  4.  Exit (Update disk configuration and exit)
  5.  Cancel (Exit without updating disk configuration)
Enter Selection: Selection: 4
WARNING: Solaris fdisk partition changed - Please relabel the disk
format> label
Ready to label disk, continue? yes
format> q

```

x86: Example—Creating a Solaris fdisk Partition and an Additional fdisk Partition

This following example shows how to create a Solaris fdisk partition and a DOSBIG fdisk partition.

```

format> fdisk
The recommended default partitioning for your disk is:
  a 100% "SOLARIS System" partition.
To select this, please type "y". To partition your disk
differently, type "n" and the "fdisk" program will let you
select other partitions. n
          Total disk size is 2694 cylinders
          Cylinder size is 765 (512 byte) blocks
                                Cylinders
Partition  Status   Type      Start  End  Length  %
=====  =====  =====  =====  ===  =====  ==

```

```

=====
THERE ARE NO PARTITIONS CURRENTLY DEFINED SELECT ONE OF THE FOLLOWING:
  1. Create a partition
  2. Change Active (Boot from) partition
  3. Delete a partition
  4. Exit (Update disk configuration and exit)
  5. Cancel (Exit without updating disk configuration)
Enter Selection: 1
Indicate the type of partition you want to create
(1=SOLARIS, 2=UNIX, 3=PCIXOS, 4=Other, 8=DOSBIG)
(5=DOS12, 6=DOS16, 7=DOSEXT, 0=Exit) ?8
Indicate the percentage of the disk you want this partition
to use (or enter "c" to specify in cylinders). 20
Do you want this to become the Active partition? If so, it will be
activated each time you reset your computer or when you turn it on
again. Please type "y" or "n". n
      Total disk size is 2694 cylinders
      Cylinder size is 765 (512 byte) blocks
              Cylinders
Partition  Status  Type      Start  End  Length  %
=====  =====  =====  =====  ===  =====  ==
          1              DOS-BIG      1   538    538    20
SELECT ONE OF THE FOLLOWING:
  1. Create a partition
  2. Change Active (Boot from) partition
  3. Delete a partition
  4. Exit (Update disk configuration and exit)
  5. Cancel (Exit without updating disk configuration)Enter
Selection: 1
Indicate the type of partition you want to create
(1=SOLARIS, 2=UNIX, 3=PCIXOS, 4=Other, 8=DOSBIG)
(5=DOS12, 6=DOS16, 7=DOSEXT, 0=Exit) ?1
Indicate the percentage of the disk you want this partition
to use (or enter "c" to specify in cylinders). 80
Do you want this to become the Active partition? If so, it will be
activated each time you reset your computer or when you turn it on
again. Please type "y" or "n". y
Partition 2 is now the Active partition Total disk size is 2694
cylinders
      Cylinder size is 765 (512 byte) blocks
              Cylinders
Partition  Status  Type      Start  End  Length  %
=====  =====  =====  =====  ===  =====  ==
          1              DOS-BIG      1   538    538    20
          2      Active  SOLARIS    539  2693   2155    80
SELECT ONE OF THE FOLLOWING:
  1. Create a partition
  2. Change Active (Boot from) partition
  3. Delete a partition
  4. Exit (Update disk configuration and exit)
  5. Cancel (Exit without updating disk configuration)
Enter Selection: 4
format> q

```

▼ x86: How to Create Disk Slices and Label a Disk

1. **Become superuser or assume an equivalent role.**

2. **Start the `format` utility.**

```
# format
```

3. **Type the number of the disk that you want to repartition from the list displayed on your screen.**

```
Specify disk (enter its number): disk-number
```

disk-number is the number of the disk that you want to repartition.

4. **Select the `partition` menu.**

```
format> partition
```

5. **Display the current partition (slice) table.**

```
partition> print
```

6. **Start the modification process.**

```
partition> modify
```

7. **Set the disk to all free hog.**

```
Choose base (enter number) [0]? 1
```

For more information about the free hog slice, see “Using the Free Hog Slice” on page 457.

8. **Create a new partition table by answering `yes` when prompted to continue.**

```
Do you wish to continue creating a new partition  
table based on above table[yes]? yes
```

9. **Identify the free hog partition (slice) and the sizes of the slices when prompted.**

When adding a system disk, you must set up slices for:

- root (slice 0) and swap (slice 1) and/or
- /usr (slice 6)

After you identify the slices, the new partition table is displayed.

10. **Make the displayed partition table the current partition table by answering `yes` when asked.**

```
Okay to make this the current partition table[yes]? yes
```

If you don't want the current partition table and you want to change it, answer no and go to Step 6.

11. **Name the partition table.**

Enter table name (remember quotes): "*partition-name*"
partition-name is the name for the new partition table.

12. Label the disk with the new partition table after you have finished allocating slices on the new disk.

Ready to label disk, continue? **yes**

13. Quit the partition menu.

```
partition> quit
```

14. Verify the new disk label.

```
format> verify
```

15. Exit the format menu.

```
format> quit
```

x86: Where to Go From Here

After you create disk slices and label the disk, you can create file systems on the disk. Go to “x86: How to Create File Systems” on page 502.

▼ x86: How to Create File Systems

1. Become superuser or assume an equivalent role.

2. Create a file system for each slice.

```
# newfs /dev/rdisk/cwtxdysz
```

/dev/rdisk/cwtxdysz is the raw device for the file system to be created.
For more information about the `newfs` command, see Chapter 39 or `newfs(1M)`.

3. Verify the new file system by mounting.

```
# mount /dev/dsk/cwtxdysz /mnt
# ls /mnt
lost+found
```

x86: Where to Go From Here

Add Disk Task	Action
System Disk	<p>You need to restore the root (/) and /usr file systems on the disk. Go to Chapter 49.</p> <p>After the root (/) and /usr file systems are restored, install the boot block. Go to “x86: How to Install a Boot Block on a System Disk” on page 503.</p>
Secondary Disk	<p>You might need to restore file systems on the new disk. Go to Chapter 49.</p> <p>If you are not restoring file systems on the new disk, you are finished adding a secondary disk. See Chapter 40 for information on making the file systems available to users.</p>

▼ x86: How to Install a Boot Block on a System Disk

1. Become superuser or assume an equivalent role.

2. Install the boot block on the system disk.

```
# installboot /usr/platform/`uname -i`/lib/fs/ufs/pboot /usr/platform/  
`uname -i` /lib/fs/ufs/bootblk /dev/rdisk/cwtxdys2
```

```
/usr/platform/`uname  
-i`/lib/fs/ufs/pboot
```

Is the partition boot file.

```
/usr/platform/`uname  
-i`/lib/fs/ufs/bootblk
```

Is the boot block code.

```
/dev/rdisk/cwtxdys2
```

Is the raw device name that represents the whole disk.

3. Verify that the boot blocks are installed by rebooting the system to run level 3.

```
# init 6
```

x86: Example—Installing a Boot Block on a System Disk

```
# installboot /usr/platform/i86pc/lib/fs/ufs/pboot  
/usr/platform/i86pc/lib/fs/ufs/bootblk /dev/rdisk/c0t6d0s2
```

The `format` Utility (Reference)

This chapter describes the `format` utility's menu and commands.

This is a list of the reference information in this chapter.

- “Recommendations and Requirements for Using The `format` Utility” on page 505
- “Format Menu and Command Descriptions” on page 506
- “The `format.dat` File” on page 512
- “Rules for Input to `format` Commands” on page 517
- “Getting Help on the `format` Utility” on page 519

For an overview of when to use the `format` utility, see Chapter 32.

Recommendations and Requirements for Using The `format` Utility

You must be superuser or a member of an equivalent role to use the `format` utility. If you are not superuser or have assumed an equivalent role, you will see the following error message when trying to use the `format` utility:

```
$ format
Searching for disks...done
No permission (or no disks found)!
```

Keep the following guidelines in mind when using the `format` utility and you want to preserve the existing data:

- Back up all files on the disk drive.
- Save all your defect lists in files by using the `format` utility's `dump` command. The file name should include the drive type, model number, and serial number.

- Save the paper copies of the manufacturer's defect list that was shipped with your drive.

Format Menu and Command Descriptions

The format main menu looks like the following:

```

FORMAT MENU:
  disk      - select a disk
  type      - select (define) a disk type
  partition - select (define) a partition table
  current   - describe the current disk
  format    - format and analyze the disk
  repair    - repair a defective sector
  label     - write label to the disk
  analyze   - surface analysis
  defect    - defect list management
  backup    - search for backup labels
  verify    - read and display labels
  save      - save new disk/partition definitions
  inquiry   - show vendor, product and revision
  volname   - set 8-character volume name
  quit
format>

```

The following table describes the format main menu items.

TABLE 36-1 The format Main Menu Item Descriptions

Item	Command or Menu?	Description
disk	Command	Lists all of the system's drives. Also lets you choose the disk you want to use in subsequent operations. This disk is referred to as the current disk.
type	Command	Identifies the manufacturer and model of the current disk. Also displays a list of known drive types. Choose the Auto configure option for all SCSI-2 disk drives.
partition	Menu	Creates and modifies slices. For more information, see "The partition Menu" on page 508.

TABLE 36-1 The `format` Main Menu Item Descriptions (Continued)

Item	Command or Menu?	Description
<code>current</code>	Command	Displays the following information about the current disk: <ul style="list-style-type: none"> ■ Device name and device type ■ Number of cylinders, alternate cylinders, heads and sectors ■ Physical device name
<code>format</code>	Command	Formats the current disk by using one of these sources of information in this order: <ol style="list-style-type: none"> 1. Information that is found in the <code>format .dat</code> file 2. Information from the automatic configuration process 3. Information that you enter at the prompt if there is no <code>format .dat</code> entry <p>This command does not apply to IDE disks. IDE disks are pre-formatted by the manufacturer.</p>
<code>fdisk</code>	Menu	x86 platform only: Runs the <code>fdisk</code> program to create a Solaris <code>fdisk</code> partition.
<code>repair</code>	Command	Repairs a specific block on the current disk.
<code>label</code>	Command	Writes a new label to the current disk.
<code>analyze</code>	Menu	Runs read, write, compare tests. For more information, see “The <code>analyze</code> Menu” on page 510.
<code>defect</code>	Menu	Retrieves and prints defect lists. For more information, see “The <code>defect</code> Menu” on page 511. This feature does not apply to IDE disks. IDE disks perform automatic defect management.
<code>backup</code>	Command	VTOC – Searches for backup labels. EFI – Not supported.
<code>verify</code>	Command	Prints the following information about the current disk: <ul style="list-style-type: none"> ■ Device name and device type ■ Number of cylinders, alternate cylinders, heads and sectors ■ Partition table
<code>save</code>	Command	VTOC –Saves new disk and partition information. EFI – Not applicable.
<code>inquiry</code>	Command	Prints the vendor, product name, and revision level of the current drive (SCSI disks only).

TABLE 36-1 The format Main Menu Item Descriptions (Continued)

Item	Command or Menu?	Description
volname	Command	Labels the disk with a new eight-character volume name.
quit	Command	Exits the format menu.

The partition Menu

The partition menu looks similar to the following:

```
format> partition
PARTITION MENU:
    0 - change '0' partition
    1 - change '1' partition
    2 - change '2' partition
    3 - change '3' partition
    4 - change '4' partition
    5 - change '5' partition
    6 - change '6' partition
    7 - change '7' partition
select - select a predefined table
modify - modify a predefined partition table
name - name the current table
print - display the current table
label - write partition map and label to the disk
quit
partition>
```

The following table describes the partition menu items.

TABLE 36-2 Descriptions for partition Menu Items

Sub-Command	Description
change 'n' partition	Lets you specify the following information for the new slice: <ul style="list-style-type: none">■ Identification tag■ Permission flags■ Starting cylinder■ Size
select	Lets you choose a predefined slice table.
modify	Lets you change all the slices in the slice table. This command is preferred over the individual change 'x' partition commands.
name	Lets you specify a name for the current slice table.

TABLE 36-2 Descriptions for partition Menu Items (Continued)

Sub-Command	Description
print	Displays the current slice table.
label	Writes the slice map and the label to the current disk.
quit	Exits the partition menu.

x86: The fdisk Menu

The fdisk menu appears on x86 based systems only and looks similar to the following.

```
format> fdisk
Total disk size is 1855 cylinders
Cylinder size is 553 (512 byte) blocks
Cylinders
Partition  Status  Type      Start  End  Length  %
=====  =====  =====  =====  ===  =====  ==
          1         DOS-BIG   0      370   371     20
          2      Active  SOLARIS  370   1851  1482     80

SELECT ONE OF THE FOLLOWING:
1.  Create a partition
2.  Change Active (Boot from) partition
3.  Delete a partition
4.  Exit (Update disk configuration and exit)
5.  Cancel (Exit without updating disk configuration)

Enter Selection:
```

The following table describes the fdisk menu items.

TABLE 36-3 x86: Descriptions for fdisk Menu Items

Menu Item	Description
Create a partition	Creates an fdisk partition. You must create a separate partition for each operating environment such as Solaris or DOS. There is a maximum of 4 partitions per disk. You are prompted for the size of the fdisk partition as a percentage of the disk.
Change Active partition	Lets you specify the partition to be used for booting. This menu item identifies where the first stage boot program looks for the second stage boot program.
Delete a partition	Deletes a previously created partition. This command destroys all the data in the partition.

TABLE 36-3 x86: Descriptions for fdisk Menu Items (Continued)

Menu Item	Description
Exit	Writes a new version of the partition table and exits the fdisk menu.
Cancel	Exits the fdisk menu without modifying the partition table.

The analyze Menu

The analyze menu looks similar to the following.

```
format> analyze
```

```
ANALYZE MENU:
```

```
  read   - read only test   (doesn't harm SunOS)
  refresh - read then write  (doesn't harm data)
  test   - pattern testing  (doesn't harm data)
  write  - write then read   (corrupts data)
  compare - write, read, compare (corrupts data)
  purge  - write, read, write (corrupts data)
  verify - write entire disk, then verify (corrupts data)
  print  - display data buffer
  setup  - set analysis parameters
  config - show analysis parameters
  quit
```

```
analyze>
```

The following table describes the analyze menu items.

TABLE 36-4 Descriptions for analyze Menu Item

Sub-Command	Description
read	Reads each sector on the current disk. Repairs defective blocks as a default.
refresh	Reads then writes data on the current disk without harming the data. Repairs defective blocks as a default.
test	Writes a set of patterns to the disk without harming the data. Repairs defective blocks as a default.
write	Writes a set of patterns to the disk then reads the data on the disk back. Destroys existing data on the disk. Repairs defective blocks as a default.
compare	Writes a set of patterns to the disk, reads the data back, and then compares it to the data in the write buffer. Destroys existing data on the disk. Repairs defective blocks as a default.

TABLE 36-4 Descriptions for analyze Menu Item (Continued)

Sub-Command	Description
purge	Removes all data from the disk so that the data can't be retrieved by any means. Data is removed by writing three distinct patterns over the entire disk (or a section of the disk). If the verification passes, a hex-bit pattern is written over the entire disk (or a section of the disk). Repairs defective blocks as a default.
verify	Writes unique data to each block on the entire disk in the first pass. Reads and verifies the data in the next pass. Destroys existing data on the disk. Repairs defective blocks as a default.
print	Displays the data in the read/write buffer.
setup	Lets you specify the following analysis parameters: Analyze entire disk? yes Starting block number: <i>depends on drive</i> Ending block number: <i>depends on drive</i> Loop continuously? no Number of passes: 2 Repair defective blocks? yes Stop after first error? no Use random bit patterns? no Number of blocks per transfer: 126 (0/n/mm) Verify media after formatting? yes Enable extended messages? no Restore defect list? yes Restore disk label? yes Defaults are shown in bold.
config	Displays the current analysis parameters.
quit	Exits the analyze menu.

The defect Menu

The defect menu looks similar to the following:

```
format> defect

DEFECT MENU:
  primary - extract manufacturer's defect list
  grown   - extract manufacturer's and repaired defects lists
  both    - extract both primary and grown defects lists
  print   - display working list
  dump    - dump working list to file
  quit

defect>
```

The following table describes the defect menu items.

TABLE 36-5 The defect Menu Item Descriptions

Sub-Command	Description
primary	Reads the manufacturer's defect list from the disk drive and updates the in-memory defect list.
grown	Reads the grown defect list, which are defects that have been detected during analysis, and then updates the in-memory defect list.
both	Reads both the manufacturer's defect list and the grown defect list, and then updates the in-memory defect list.
print	Displays the in-memory defect list.
dump	Saves the in-memory defect list to a file.
quit	Exits the defect menu.

The format .dat File

The `format .dat` file that is shipped with the Solaris operating environment supports many standard disks. If your disk drive is not listed in the `format .dat` file, you can choose to add an entry for it or adding entries with the `format` utility by selecting the `type` command and choosing the `other` option.

Adding an entry to the `format .dat` file can save time if the disk drive will be used throughout your site. To use the `format .dat` file on other systems, copy the file to each system that will use the specific disk drive that you added to the `format .dat` file.

You should modify the `/etc/format .dat` file for your system if you have one of the following:

- A disk that is not supported by the Solaris operating environment
- A disk with a slice table that is different from the Solaris operating environment default configuration

Note – Do not alter default entries in the `/etc/format .dat` file. If you want to alter the default entries, copy the entry, give it a different name, and make the appropriate changes to avoid confusion.

The `/etc/format .dat` is not applicable for disks with EFI labels.

Contents of the `format.dat` File

The `format.dat` contains specific disk drive information that is used by the `format` utility. Three items are defined in the `format.dat` file:

- Search paths
- Disk types
- Slice tables

Syntax of the `format.dat` File

The following syntax rules apply to the `/etc/format.dat` file:

- The pound sign (`#`) is the comment character. Any text on a line after a pound sign is not interpreted by the `format` utility.
- Each definition in the `format.dat` file appears on a single logical line. If the definition is longer than one line long, all but the last line of the definition must end with a backslash (`\`).
- A definition consists of a series of assignments that have an identifier on the left side and one or more values on the right side. The assignment operator is the equal sign (`=`). The assignments within a definition must be separated by a colon (`:`).
- White space is ignored by the `format` utility. If you want an assigned value to contain white space, enclose the entire value in double quotation marks (`"`). This syntax will cause the white space within the quotes to be preserved as part of the assignment value.
- Some assignments can have multiple values on the right hand side. Separate values by a comma.

Keywords in the `format.dat` File

The `format.dat` file contains disk definitions that are read by the `format` utility when it is started. Each definition starts with one of the following keywords: `disk_type` or `partition`. These keywords are described in the following table.

TABLE 36-6 Keyword Descriptions for the `format.dat` File

Keyword	Use
<code>disk_type</code>	<p>Defines the controller and disk model. Each <code>disk_type</code> definition contains information that concerns the physical geometry of the disk. The default data file contains definitions for the controllers and disks that the Solaris operating environment supports.</p> <p>You need to add a new <code>disk_type</code> only if you have an unsupported disk. You can add as many <code>disk_type</code> definitions to the data file as you want.</p>
<code>partition</code>	<p>Defines a slice table for a specific disk type. The slice table contains the slice information, plus a name that lets you refer to it in the <code>format</code> utility. The default <code>format.dat</code> file contains default slice definitions for several kinds of disk drives. Add a slice definition if you recreated slices on any of the disks on your system. Add as many slice definitions to the data file as you need.</p>

Disk Type (`format.dat`)

The `disk_type` keyword in the `format.dat` file defines the controller and disk model. Each `disk_type` definition contains information about the physical geometry of the disk. The default `format.dat` file contains definitions for the controllers and disks that the Solaris operating environment supports. You need to add a new `disk_type` only if you have an unsupported disk. You can add as many `disk_type` definitions to the data file as you want.

The keyword itself is assigned the name of the disk type. This name appears in the disk's label, and is used to identify the disk type whenever the `format` utility is run. Enclose the name in double quotation marks to preserve any white space in the name. The following table describes the identifiers that must also be assigned values in all `disk_type` definitions.

TABLE 36-7 Required `disk_type` Identifiers

Identifier	Description
<code>ctrlr</code>	Identifies the controller type for the disk type. Currently, the supported values are SCSI and ATA.
<code>ncyl</code>	Specifies the number of data cylinders in the disk type. This determines how many logical cylinders of the disk the system will be allowed to access.
<code>acyl</code>	Specifies the number of alternate cylinders in the disk type. These cylinders are used by the <code>format</code> utility to store information such as the defect list for the drive. You should always leave at least two cylinders for alternates.

TABLE 36-7 Required `disk_type` Identifiers (Continued)

Identifier	Description
<code>pcyl</code>	Specifies the number of physical cylinders in the disk type. This number is used to calculate the boundaries of the disk media. This number is usually equal to <code>ncyl</code> plus <code>acyl</code> .
<code>nhead</code>	Specifies the number of heads in the disk type. This number is used to calculate the boundaries of the disk media.
<code>nsect</code>	Specifies the number of data sectors per track in the disk type. This number is used to calculate the boundaries of the disk media. Note that this is only the data sectors. Any spares are not reflected in the number of data sections per track.
<code>rpm</code>	The rotations per minute of the disk type. This information is put in the label and later used by the file system to calculate the optimal placement of file data.

Other identifiers might be necessary, depending on the controller. The following table describes the identifiers that are required for SCSI controllers.

TABLE 36-8 `disk_type` Identifiers for SCSI Controllers

Identifier	Description
<code>fmt_time</code>	A number that Indicates how long it takes to format a given drive. See the controller manual for more information.
<code>cache</code>	A number that controls the operation of the on-board cache while the <code>format</code> utility is operating. See the controller manual for more information.
<code>trks_zone</code>	A number that specifies how many tracks you have per defect zone, to be used in alternate sector mapping. See the controller manual for more information.
<code>asect</code>	A number that specifies how many sectors are available for alternate mapping within a given defect zone. See the controller manual for more information.

The following are examples of `disk_type` definitions:

```
disk_type = "SUN1.3G" \
: ctlr = SCSI : fmt_time = 4 \
: trks_zone = 17 : asect = 6 : atrks = 17 \
: ncyl = 1965 : acyl = 2 : pcyl = 3500 : nhead = 17 : nsect = 80 \
: rpm = 5400 : bpt = 44823
```

```
disk_type = "SUN2.1G" \
: ctlr = SCSI : fmt_time = 4 \
: ncyl = 2733 : acyl = 2 : pcyl = 3500 : nhead = 19 : nsect = 80 \
: rpm = 5400 : bpt = 44823
```

```
disk_type = "SUN2.9G" \
: ctlr = SCSI : fmt_time = 4 \
```

```
: ncyl = 2734 : acyl = 2 : pcyl = 3500 : nhead = 21 : nsect = 99 \  
: rpm = 5400
```

Partition or Slice Tables (format.dat)

A partition table in the `format.dat` file defines a slice table for a specific disk type.

The `partition` keyword in the `format.dat` file is assigned the name of the slice table. Enclose the name in double quotation marks to preserve any white space in the name. The following table describes the identifiers that must be assigned values in all slice tables.

TABLE 36-9 Required Identifiers for Slice Tables

Identifier	Description
<code>disk</code>	The name of the <code>disk_type</code> that this slice table is defined for. This name must appear exactly as it does in the <code>disk_type</code> definition.
<code>ctlr</code>	The disk controller type that this slice table can be attached to. Currently, the supported values are ATA for ATA controllers and SCSI for SCSI controllers. The controller type that is specified here must also be defined for the <code>disk_type</code> that you specified in the <code>disk_type</code> definition.

The other identifiers in a slice definition describe the actual slice information. The identifiers are the numbers 0 through 7. These identifiers are optional. Any slice that is not explicitly assigned is set to 0 length. The value of each of these identifiers is a pair of numbers separated by a comma. The first number is the starting cylinder for the slice, and the second is the number of sectors in the slice. The following are some examples of slice definitions:

```
partition = "SUN1.3G" \  
: disk = "SUN1.3G" : ctlr = SCSI \  
: 0 = 0, 34000 : 1 = 25, 133280 : 2 = 0, 2672400 : 6 = 123, 2505120  
  
partition = "SUN2.1G" \  
: disk = "SUN2.1G" : ctlr = SCSI \  
: 0 = 0, 62320 : 1 = 41, 197600 : 2 = 0, 4154160 : 6 = 171, 3894240  
  
partition = "SUN2.9G" \  
: disk = "SUN2.9G" : ctlr = SCSI \  
: 0 = 0, 195426 : 1 = 94, 390852 : 2 = 0, 5683986 : 6 = 282, 5097708
```

Specifying an Alternate Data File for the format utility

The `format` utility learns of the location of an alternate file by the following methods.

1. If a file name is given with the `format -x` option, that file is always used as the data file.
2. If the `-x` option is not specified, then the `format` utility looks in the current directory for a file named `format.dat`. If the file exists, it is used as the data file.
3. If neither of these methods yields a data file, the `format` utility uses the `/etc/format.dat` file as the data file. This file is shipped with the Solaris operating environment and should always be present.

Rules for Input to `format` Commands

When you use the `format` utility, you need to provide various kinds of information. This section describes the rules for this information. For information on using `format`'s help facility when you enter data, see "Getting Help on the `format` Utility" on page 519.

Specifying Numbers to `format` Commands

Several places in the `format` utility require an number as input. You must either specify the data or select a number from a list of choices. In either case, the `help` facility causes `format` to print the upper and lower limits of the number expected. Simply enter the number desired. The number is assumed to be in decimal format unless a base is explicitly specified as part of the number (for example, `0x` for hexadecimal).

The following are examples of integer input:

```
Enter number of passes [2]: 34
Enter number of passes [34] 0xf
```

Specifying Block Numbers to `format` Commands

Whenever you are required to specify a disk block number, there are two ways to enter the information:

- Block number as an integer
- Block number in the cylinder/head/sector format

You can specify the information as an integer that represents the logical block number. You can specify the number in any base, but the default is decimal. The maximum operator (a dollar sign, `$`) can also be used here to let the `format` utility select the appropriate value. Logical block format is used by the SunOS disk drivers in error messages.

The other way to specify a block number is by the cylinder/head/sector designation. In this method, you must specify explicitly the three logical components of the block number: the cylinder, head, and sector values. These values are still logical, but they allow you to define regions of the disk that are related to the layout of the media.

If any of the cylinder/head/sector numbers are not specified, the value is assumed to be zero. You can also use the maximum operator in place of any of the numbers and let the `format` utility select the appropriate value. The following are some examples of cylinder, head, and sector entries:

```
Enter defective block number: 34/2/3
Enter defective block number: 23/1/
Enter defective block number: 457//
Enter defective block number: 12345
Enter defective block number: 0xabcd
Enter defective block number: 334/$/2
Enter defective block number: 892//
```

The `format` utility always prints block numbers, in both formats. Also, the `help` facility shows you the upper and lower bounds of the block number expected, in both formats.

Specifying format Command Names

Command names are needed as input whenever the `format` utility displays a menu prompt. You can *abbreviate* the command names, as long as what you enter is sufficient to uniquely identify the command desired.

For example, use `p` to enter the partition menu from the `format` menu. Then, enter `p` to display the current slice table.

```
format> p
PARTITION MENU:
  0 - change '0' partition
  1 - change '1' partition
  2 - change '2' partition
  3 - change '3' partition
  4 - change '4' partition
  5 - change '5' partition
  6 - change '6' partition
  7 - change '7' partition
select - select a predefined table
modify - modify a predefined partition table
name - name the current table
print - display the current table
label - write partition map and label to the disk
quit
partition> p
```

Specifying Disk Names to `format` Commands

There are certain times in the `format` utility when you must name something. In these cases, you are free to specify any string you want for the name. If the name has white space in it, the entire name must be enclosed in double quotation marks ("). Otherwise, only the first word of the name is used.

For example, if you want to identify a specific partition table for a disk, you can use the `name` sub-command available from the partition menu:

```
partition> name
Enter table name (remember quotes): "new disk3"
```

Getting Help on the `format` Utility

The `format` utility provides a help facility that you can use whenever the `format` utility is expecting input. You can request help about what input is expected by entering a question mark (?). The `format` utility displays a brief description of what type of input is needed.

If you enter a ? at a menu prompt, a list of available commands is displayed.

The man pages associated with the `format` utility include the following:

- `format(1M)` - Describes the basic `format` utility capabilities and provides descriptions of all command-line variables.
- `format.dat(4)` - Describes disk drive configuration information for the `format` utility.

Managing File Systems Topics

This topic map lists the chapters that provide information on managing file systems.

Chapter 38	Provides a high-level overview of file system topics, including descriptions of file system types, commonly used administration commands, and the mounting and unmounting of file systems. Also includes the procedure for determining a file system's type.
Chapter 39	Provides step-by-step instructions for creating a UFS file system, a temporary file system (TMPFS), and a loopback file system (LOFS).
Chapter 40	Provides step-by-step instructions for determining which file systems are mounted, how to mount files listed in the <code>/etc/vfstab</code> file, and how to mount UFS, NFS, and PCFS (DOS) file systems.
Chapter 41	Provides overview information and step-by-step instructions for using the CacheFS file system.
Chapter 42	Provides step-by-step instructions for monitoring swap resources, creating swap files and making them available, and removing unneeded swap space.
Chapter 43	Provides information on how the file system state is recorded, what <code>fsck</code> program checks, how to modify automatic boot checking, and how to use the <code>fsck</code> program.
Chapter 44	Provides reference information for file systems, including default directories for the root (<code>/</code>) and <code>/usr</code> file systems, default directories that are contained in the <code>/kernel</code> directory, and specifics for the <code>mkfs</code> and <code>newfs</code> commands.

Managing File Systems (Overview)

The management of file systems is one of your most important system administration tasks.

This is a list of the overview information in this chapter.

- “What’s New in File Systems in the Solaris 9 8/03 Release?” on page 523
- “What’s New in File Systems in the Solaris 9 Release?” on page 529
- “Where to Find File System Management Tasks” on page 532
- “Overview of File Systems” on page 532
- “Types of File Systems” on page 533
- “Commands for File System Administration” on page 537
- “The Default Solaris File Systems” on page 539
- “Swap Space” on page 540
- “The UFS File System” on page 540
- “Mounting and Unmounting File Systems” on page 543
- “Determining a File System’s Type” on page 548

What’s New in File Systems in the Solaris 9 8/03 Release?

This section describes a new file system feature in this Solaris release.

SPARC: Support of Multiterabyte UFS File Systems

This Solaris release provides support for multiterabyte UFS file systems on systems that are running a 64-bit Solaris kernel.

Previously, UFS file systems were limited to approximately 1 terabyte on both 64-bit and 32-bit systems. All UFS file system commands and utilities have been updated to support multiterabyte UFS file systems.

For example, the `ufsdump` command has been updated with a larger block size for dumping large UFS file systems:

```
# ufsdump 0f /dev/md/rdisk/d97 /dev/md/rdisk/d98
DUMP: Date of this level 0 dump: Tue Jan 07 14:23:36 2003
DUMP: Date of last level 0 dump: the epoch
DUMP: Dumping /dev/md/rdisk/d98 to /dev/md/rdisk/d97.
DUMP: Mapping (Pass I) [regular files]
DUMP: Mapping (Pass II) [directories]
DUMP: Forcing larger tape block size (2048).
DUMP: Writing 32 Kilobyte records
DUMP: Estimated 4390629500 blocks (2143862.06MB).
DUMP: Dumping (Pass III) [directories]
DUMP: Dumping (Pass IV) [regular files]
```

Administering UFS file systems that are less than 1 terabyte remains the same. No administration differences exist between UFS file systems that are less than one terabyte and file systems that are greater than 1 terabyte.

You can initially create a UFS file system that is less than 1 terabyte and specify that it can eventually be expanded into a multiterabyte file system by using the `newfs -T` option. This option sets the inode and fragment density to scale appropriately for a multiterabyte file system.

Using the `newfs -T` option when you create a UFS file system less than 1 terabyte on a system running a 32-bit kernel enables you to eventually expand this file system with the `growfs` command when you boot this system under a 64-bit kernel. For more information, see `newfs(1M)`.

You can use the `growfs` command to expand a UFS file system to the size of the slice or the volume without loss of service or data. For more information, see `growfs(1M)`.

Two new related features are multiterabyte volume support with the EFI disk label and multiterabyte volume support with Solaris Volume Manager. For more information, see “SPARC: Multiterabyte Volume Support With EFI Disk Label” on page 440 and the *Solaris Volume Manager Administration Guide*

Features of Multiterabyte UFS File Systems

Multiterabyte UFS file systems include the following features:

- The ability to create a UFS file system up to 16 terabytes in size.
- The ability to create a file system less than 16 terabytes that can later be increased in size up to 16 terabytes.
- Multiterabyte file systems can be created on physical disks, Solaris Volume Manager’s logical volumes, and Veritas’ VxVM logical volumes.

- UFS logging is enabled by default on file systems greater than 1 terabyte. Multiterabyte file systems benefit from the performance improvements of having UFS logging enabled. Multiterabyte file systems also benefit from the availability of logging because the `fsck` command might not have to be run when logging is enabled.

Limitations of Multiterabyte UFS File Systems

Limitations of multiterabyte UFS file systems are as follows:

- This feature is not supported on Solaris x86 systems.
- You cannot mount a file system greater than 1 terabyte on a system that is running a 32-bit Solaris kernel.
- You cannot boot from a file system greater than 1 terabyte on a system that is running a 64-bit Solaris kernel. This limitation means that you cannot put a root (`/`) file system on a multiterabyte file system.
- There is no support for individual files greater than 1 terabyte.
- The maximum number of files per terabyte of UFS file system is 1 million. This limit is intended to reduce the time it takes to check the file system with the `fsck` command.
- The maximum quota that you can set on a multiterabyte UFS file system is 2 terabytes of 1024-byte blocks.
- Using the `fsnap` command to create a snapshot of a multiterabyte UFS file system is not currently supported.

▼ How to Create a Multiterabyte UFS File System

Support for a multiterabyte UFS file system assumes the availability of multiterabyte LUNs, provided as Solaris Volume Manager or VxVM volumes, or as physical disks greater than 1 terabyte.

Before you can create a multiterabyte UFS file system, verify that you have done either of the following:

- Created a multiterabyte disk partition with the `format` utility or the Solaris installation utilities.
- Set up a multiterabyte volume with Solaris Volume Manager.

1. Become superuser.

2. Create a multiterabyte UFS file system on a logical volume.

For example, this command creates a UFS file system for a 1.8 terabyte volume.

```
# newfs /dev/md/rdisk/d99
newfs: construct a new file system /dev/md/rdisk/d99: (y/n)? y
/dev/md/rdisk/d99: 3859402752 sectors in 628158 cylinders of 48 tracks,
```

```

128 sectors
      1884474.0MB in 4393 cyl groups (143 c/g, 429.00MB/g, 448 i/g)
super-block backups (for fsck -F ufs -o b=#) at:
32, 878752, 1757472, 2636192, 3514912, 4393632, 5272352, 6151072, 702...
Initializing cylinder groups:
.....
super-block backups for last 10 cylinder groups at:
 3850872736, 3851751456, 3852630176, 3853508896, 3854387616, 3855266336,
 3856145056, 3857023776, 3857902496, 3858781216,
#

```

3. Verify the integrity of the newly created file system.

For example:

```

# fsck /dev/md/rdisk/d99
** /dev/md/rdisk/d99
** Last Mounted on
** Phase 1 - Check Blocks and Sizes
** Phase 2 - Check Pathnames
** Phase 3 - Check Connectivity
** Phase 4 - Check Reference Counts
** Phase 5 - Check Cyl groups
2 files, 2 used, 241173122 free (0 frags, 241173122 blocks, 0.0%
fragmentation)
#

```

4. Mount and verify the newly created file system.

For example:

```

# mount /dev/md/dsk/d99 /bigdir
# df -h /bigdir

```

Filesystem	size	used	avail	capacity	Mounted on
/dev/md/dsk/d99	1.8T	64M	1.8T	1%	/bigdir

▼ How to Expand a Multiterabyte UFS File System

After a multiterabyte UFS file system is created, you can use the `growfs` command to expand the file system. For example, using the file system that was created for the volume in the preceding procedure, you can add another disk to this volume. Then, expand the file system.

1. Become superuser.

2. Add another disk to the volume.

For example:

```

# metattach d99 c4t5d0s4
d99: component is attached
# metastat
d99: Concat/Stripe
      Size: 5145882624 blocks (2.4 TB)
      Stripe 0:

```

Device	Start Block	Dbase	Reloc
c0t1d0s4	36864	Yes	Yes
Stripe 1:			
Device	Start Block	Dbase	Reloc
c3t7d0s4	0	No	Yes
Stripe 2:			
Device	Start Block	Dbase	Reloc
c1t1d0s4	0	No	Yes
Stripe 3:			
Device	Start Block	Dbase	Reloc
c4t5d0s4	0	No	Yes

3. Expand the file system.

For example:

```
# growfs -v /dev/md/rdisk/d99
/usr/lib/fs/ufs/mkfs -G /dev/md/rdisk/d99 5145882624
/dev/md/rdisk/d99: 5145882624 sectors in 837546 cylinders of 48 tracks,
128 sectors
    2512638.0MB in 5857 cyl groups (143 c/g, 429.00MB/g, 448 i/g)
super-block backups (for fsck -F ufs -o b=#) at:
 32, 878752, 1757472, 2636192, 3514912, 4393632, 5272352, 6151072, 702...
Initializing cylinder groups:
.....
super-block backups for last 10 cylinder groups at:
 5137130400, 5138009120, 5138887840, 5139766560, 5140645280, 5141524000,
 5142402720, 5143281440, 5144160160, 5145038880,
#
```

4. Mount and verify the expanded file system.

For example:

```
# mount /dev/md/dsk/d99 /bigdir
# df -h /bigdir
Filesystem              size  used  avail capacity  Mounted on
/dev/md/dsk/d99         2.4T   64M   2.4T     1%    /bigdir
```

▼ How to Expand a UFS File System to a Multiterabyte UFS File System

Use the following procedure to expand a UFS file system to greater than 1 terabyte in size. This procedure assumes that the `newfs -T` option was used initially to create the UFS file system.

1. Become superuser.

2. Identify the size of the current disk or volume.

For example, the following volume is 800 gigabytes.

```
# metastat d98
d98: Concat/Stripe
    Size: 1677754368 blocks (800 GB)
```

```

Stripe 0:
  Device      Start Block  Dbase  Reloc
  c0t1d0s4    0          No     Yes
Stripe 1:
  Device      Start Block  Dbase  Reloc
  c3t7d0s4    0          No     Yes

```

3. Increase the volume to greater than 1 terabyte.

For example:

```

# metattach d98 c1t1d0s4
d98: component is attached
# metastat d98
d98: Concat/Stripe
     Size: 2516631552 blocks (1.2 TB)
Stripe 0:
  Device      Start Block  Dbase  Reloc
  c0t1d0s4    0          No     Yes
Stripe 1:
  Device      Start Block  Dbase  Reloc
  c3t7d0s4    0          No     Yes
Stripe 2:
  Device      Start Block  Dbase  Reloc
  c1t1d0s4    0          No     Yes

```

4. Expand the UFS file system for the disk or volume to greater than 1 terabyte.

For example:

```

growfs -v /dev/md/rdisk/d98
/usr/lib/fs/ufs/mkfs -G /dev/md/rdisk/d98 2516631552
/dev/md/rdisk/d98: 2516631552 sectors in 68268 cylinders of 144 tracks,
256 sectors
      1228824.0MB in 2731 cyl groups (25 c/g, 450.00MB/g, 448 i/g)
super-block backups (for fsck -F ufs -o b=#) at:
 32, 921888, 1843744, 2765600, 3687456, 4609312, 5531168, 6453024, 737...
8296736,
Initializing cylinder groups:
.....
super-block backups for last 10 cylinder groups at:
2507714848, 2508636704, 2509558560, 2510480416, 2511402272, 2512324128,
2513245984, 2514167840, 2515089696, 2516011552,

```

5. Mount and verify the expanded file system.

For example:

```

# mount /dev/md/dsk/d98 /datadir
# df -h /datadir
Filesystem      size  used  avail capacity  Mounted on
/dev/md/dsk/d98 1.2T   64M   1.2T     1%    /datadir

```

Troubleshooting Multiterabyte UFS File System Problems

Use the following error messages and solutions to troubleshoot problems with multiterabyte UFS file systems.

Error Message (similar to the following):

```
mount: /dev/rdisk/c0t0d0s0 is not this fstype.
```

Cause

You attempted to mount a UFS file system that is greater than 1 terabyte on a system running a Solaris release prior to the Solaris 9 8/03 release.

Solution

Mount a UFS file system that is greater than 1 terabyte on a system running the Solaris 9 8/03 or later release.

Error Message

```
"File system was not set up with the multi-terabyte format." "Its size cannot be increased to a terabyte or more."
```

Cause

You attempted to expand a file system that was not created with the `newfs -T` command.

Solution

1. Back up the data for the file system that you want to expand to greater than one terabyte.
2. Re-create the file system with the `newfs` command to create a multiterabyte file system or use the `newfs -T` command if the file system will be grown to a multiterabyte file system over time.
3. Restore the backup data into the newly created file system.

What's New in File Systems in the Solaris 9 Release?

This section describes new file system features in the Solaris 9 release.

Extended File Attributes

The UFS, NFS, and TMPFS file systems have been enhanced to include extended file attributes, which enable application developers to associate specific attributes to a file. For example, a developer of a windowing system file management application might choose to associate a display icon with a file. Extended file attributes are logically represented as files within a hidden directory that is associated with the target file.

You can use the `runat` command to add attributes and execute shell commands in the extended attribute name space, which is a hidden attribute directory that is associated with the specified file.

To use the `runat` command to add attributes to a file, you first have to create the attributes file.

```
$ runat filea cp /tmp/attrdata attr.1
```

Then, use the `runat` command to list the attributes of a file.

```
$ runat filea ls -l
```

For more information, see the `runat(1)` man page.

Many Solaris file system commands have been modified to support file system attributes by providing an attribute-aware option that you can use to query, copy, or find file attributes. For more information, see the specific man page for each file system command.

UFS Snapshots

You can use the `fssnap` command to create a read-only snapshot of a file system. A snapshot is a file system's temporary image that is intended for backup operations.

See Chapter 48 for more information.

Improved UFS Direct I/O Concurrency

The performance of direct I/O, which is used by database applications to access unbuffered file system data, has been improved by allowing concurrent read and write access to regular UFS files. Previously, an operation that updated file data would lock out all other read or write accesses until the update operation was completed.

Concurrent writes are restricted to the special case of file rewrites. If the file is being extended, writing is single threaded as before. Generally, databases pre-allocate files and seldomly extend them thereafter. Therefore, the effects of this enhancement are evident during normal database operations.

The direct I/O improvements brings I/O bound database performance on a UFS file system to about 90% of raw partition access speeds. If the database is CPU bound or bus bandwidth bound, there might be no improvement.

Consider running your I/O database applications with direct I/O enabled if you are already using UFS to store database tables. Use your database administrative procedures to enable direct I/O, if possible. If there is no way to enable direct I/O through your database product, use the `mount -forcedirectio` option to enable direct I/O for each file system. Or, use the `directio(3C)` library call to enable direct I/O.

See `mount_ufs(1M)` or `directio(3C)` for more information.

Improved `mkfs` Performance

The `mkfs` command now has improve performance when you create file systems. Improved `mkfs` performance is often 10 times faster than in previous Solaris releases. Performance improvements occur on systems when you create both large and small file systems. However, the biggest performance improvements occur when creating file systems on systems with high-capacity disks or high-speed disks.

New `labelit` Options for UDF File Systems

The `labelit` command provides new options for use with Universal Disk Format (UDF) file systems. You can use the new `labelit` command options to identify the author name, organization, and contact information for a UDF volume.

There was no mechanism to update this information, which is part of general UDF file systems, in previous Solaris releases.

The new UDF specific options for the `labelit` command, specified with the `-o` option, are the following:

- `lvinfos1` - Identifies the person who is creating the file system
- `lvinfos2` - Identifies the organization that is responsible for creating the file system
- `lvinfos3` - Identifies the contact information for media that contains the UDF file system

The maximum length for each option is 35 bytes.

For more information, see `labelit_udfs(1M)`.

Where to Find File System Management Tasks

Use these references to find step-by-step instructions for the management of file systems.

File System Management Task	For More Information
Create new file systems	Chapter 39 and Chapter 41
Make local and remote files available to users	Chapter 40
Connect and configure new disk devices	Chapter 32
Design and implement a backup schedule and restoring files and file systems, as needed	Chapter 46
Check for and correct file system inconsistencies	Chapter 43

Overview of File Systems

A file system is a structure of directories that is used to organize and store files. The term *file system* is used to describe the following:

- A particular type of file system: disk-based, network-based, or virtual
- The entire file tree, beginning with the root directory
- The data structure of a disk slice or other media storage device
- A portion of a file tree structure that is attached to a mount point on the main file tree so that the files are accessible

Usually, you can tell from the context which meaning is intended.

The Solaris operating environment uses the *virtual file system* (VFS) architecture, which provides a standard interface for different file system types. The VFS architecture enables the kernel to handle basic operations, such as reading, writing, and listing files, and makes it easier to add new file systems.

Types of File Systems

The Solaris operating environment supports three types of file systems:

- Disk-based
- Network-based
- Virtual

To identify the file system type, see “Determining a File System’s Type” on page 548.

Disk-Based File Systems

Disk-based file systems are stored on physical media such as hard disks, CD-ROMs, and diskettes. Disk-based file systems can be written in different formats. The available formats are the following:

Disk-Based File System	Format Description
UFS	<p>UNIX file system (based on the BSD Fast File system that was provided in the 4.3 Tahoe release). UFS is the default disk-based file system for the Solaris operating environment.</p> <p>Before you can create a UFS file system on a disk, you must format the disk and divide it into slices. For information on formatting disks and dividing disks into slices, see Chapter 32.</p>
HSFS	<p>High Sierra, Rock Ridge, and ISO 9660 file system. High Sierra is the first CD-ROM file system. ISO 9660 is the official standard version of the High Sierra File System. The HSFS file system is used on CD-ROMs, and is a read-only file system. Solaris HSFS supports Rock Ridge extensions to ISO 9660, which, when present on a CD-ROM, provide all UFS file system features and file types, except for writability and hard links.</p>
PCFS	<p>PC file system, which allows read and write access to data and programs on DOS-formatted disks that are written for DOS-based personal computers.</p>
UDF	<p>The Universal Disk Format (UDF) file system, the industry-standard format for storing information on the optical media technology called DVD (Digital Versatile Disc or Digital Video Disc).</p>

Each type of disk-based file system is customarily associated with a particular media device, as follows:

- UFS with hard disk

- HSFS with CD-ROM
- PCFS with diskette
- UDF with DVD

These associations are not, however, restrictive. For example, CD-ROMs and diskettes can have UFS file systems created on them.

Network-Based File Systems

Network-based file systems can be accessed from the network. Typically, network-based file systems reside on one system, typically a server, and are accessed by other systems across the network.

With NFS, you can administer distributed *resources* (files or directories) by exporting them from a server and mounting them on individual clients. For more information, see “The NFS Environment” on page 547.

Virtual File Systems

Virtual file systems are memory-based file systems that provide access to special kernel information and facilities. Most virtual file systems do not use file system disk space. However, the CacheFS file system uses a file system on the disk to contain the cache. Also, some virtual file systems, such as the temporary file system (TMPFS), use the swap space on a disk.

The CacheFS File System

The CacheFS™ file system can be used to improve performance of remote file systems or slow devices such as CD-ROM drives. When a file system is cached, the data that is read from the remote file system or CD-ROM is stored in a cache on the local system.

If you want to improve the performance and scalability of an NFS or CD-ROM file system, you should use the CacheFS file system. The CacheFS software is a general purpose caching mechanism for file systems that improves NFS server performance and scalability by reducing server and network load.

Designed as a layered file system, the CacheFS software provides the ability to cache one file system on another. In an NFS environment, CacheFS software increases the client per server ratio, reduces server and network loads, and improves performance for clients on slow links, such as Point-to-Point Protocol (PPP). You can also combine a CacheFS file system with the AutoFS service to help boost performance and scalability.

For detailed information about the CacheFS file system, see Chapter 41.

The Universal Disk Format (UDF) File System

The UDF file system is the industry-standard format for storing information on the *DVD* (Digital Versatile Disc or Digital Video Disc) optical media.

The UDF file system is provided as dynamically loadable, 32-bit and 64-bit modules, with system administration utilities for creating, mounting, and checking the file system on both SPARC and x86 platforms. The Solaris UDF file system works with supported ATAPI and SCSI DVD drives, CD-ROM devices, and disk and diskette drives. In addition, the Solaris UDF file system is fully compliant with the UDF 1.50 specification.

The UDF file system provides the following features:

- Ability to access the industry standard CD-ROM and DVD-ROM media when they contain a UDF file system
- Flexibility in exchanging information across platforms and operating systems
- A mechanism for implementing new applications rich in broadcast-quality video, high-quality sound along with the richness in interactivity using the DVD video specification based on UDF format

The following features are not included in the UDF file system:

- Support for write-once media, CD-RW, and DVD-RAM, with either the sequential disk-at-once and incremental recording
- UFS components such as quotas, ACLs, transaction logging, file system locking, and file system threads, which are not part of the UDF 1.50 specification

The UDF file system requires the following:

- The Solaris 7 11/99, Solaris 8, Solaris 9 release
- Supported SPARC or x86 platforms
- Supported CD-ROM or DVD-ROM device

The Solaris UDF file system implementation provides:

- Support for industry-standard read/write UDF version 1.50
- Fully internationalized file system utilities

Temporary File System

The temporary file system (TMPFS) uses local memory for file system reads and writes, which is typically much faster than a UFS file system. Using TMPFS can improve system performance by saving the cost of reading and writing temporary files to a local disk or across the network. For example, temporary files are created when you compile a program, and the operating system generates a lot of disk activity or network activity while manipulating these files. Using TMPFS to hold these temporary files can significantly speed up their creation, manipulation, and deletion.

Files in TMPFS file systems are not permanent. They are deleted when the file system is unmounted and when the system is shut down or rebooted.

TMPFS is the default file system type for the `/tmp` directory in the Solaris operating environment. You can copy or move files into or out of the `/tmp` directory, just as you would in a UFS file system.

The TMPFS file system uses swap space as a temporary backing store. If a system with a TMPFS file system does not have adequate swap space, two problems can occur:

- The TMPFS file system can run out of space, just as regular file systems do.
- Because TMPFS allocates swap space to save file data (if necessary), some programs might not execute because of insufficient swap space.

For information about creating TMPFS file systems, see Chapter 39. For information about increasing swap space, see Chapter 42.

The Loopback File System

The loopback file system (LOFS) lets you create a new virtual file system so that you can access files by using an alternative path name. For example, you can create a loopback mount of root (`/`) on `/tmp/newroot`, which will make the entire file system hierarchy look like it is duplicated under `/tmp/newroot`, including any file systems mounted from NFS servers. All files will be accessible either with a path name starting from root (`/`), or with a path name that starts from `/tmp/newroot`.

For information on how to create LOFS file systems, see Chapter 39.

Process File System

The process file system (PROCFS) resides in memory and contains a list of active processes, by process number, in the `/proc` directory. Information in the `/proc` directory is used by commands like `ps`. Debuggers and other development tools can also access the address space of the processes by using file system calls.



Caution – Do not delete the files in the `/proc` directory. The deletion of processes from the `/proc` directory does not kill them. Remember, `/proc` files do not use disk space, so there is little reason to delete files from this directory.

The `/proc` directory does not require administration.

Additional Virtual File Systems

These additional types of virtual file systems are listed for your information. They do not require administration.

Virtual File System	Description
FIFOFS (first-in first-out)	Named pipe files that give processes common access to data
FDFS (file descriptors)	Provides explicit names for opening files using file descriptors
MNTFS	Provides read-only access to the table of mounted file systems for the local system
NAMEFS	Used mostly by STREAMS for dynamic mounts of file descriptors on top of files
SPECFS (special)	Provides access to character special devices and block devices
SWAPFS	Used by the kernel for swapping

Commands for File System Administration

Most commands for file system administration have both a generic component and a file system-specific component. Whenever possible, you should use the generic commands, which call the file system-specific component. The following table lists the generic commands for file system administration, which are located in the `/usr/sbin` directory.

TABLE 38-1 Generic Commands for File System Administration

Command	Man Page	Description
<code>clri</code>	<code>clri(1M)</code>	Clears inodes
<code>df</code>	<code>df(1M)</code>	Reports the number of free disk blocks and files
<code>ff</code>	<code>ff(1M)</code>	Lists file names and statistics for a file system
<code>fsck</code>	<code>fsck(1M)</code>	Checks the integrity of a file system and repairs any damage found

TABLE 38-1 Generic Commands for File System Administration (Continued)

Command	Man Page	Description
<code>fsdb</code>	<code>fsdb(1M)</code>	Debugs the file system
<code>fstyp</code>	<code>fstyp(1M)</code>	Determines the file system type
<code>labelit</code>	<code>labelit(1M)</code>	Lists or provides labels for file systems when they are copied to tape (for use by the <code>volcopy</code> command only)
<code>mkfs</code>	<code>mkfs(1M)</code>	Creates a new file system
<code>mount</code>	<code>mount(1M)</code>	Mounts local and remote file systems
<code>mountall</code>	<code>mountall(1M)</code>	Mounts all file systems that are specified in the virtual file system table (<code>/etc/vfstab</code>)
<code>ncheck</code>	<code>ncheck(1M)</code>	Generates a list of path names with their inode numbers
<code>umount</code>	<code>mount(1M)</code>	Unmounts local and remote file systems
<code>umountall</code>	<code>mountall(1M)</code>	Unmounts all file systems that are specified in a virtual file system table (<code>/etc/vfstab</code>)
<code>volcopy</code>	<code>volcopy(1M)</code>	Creates an image copy of a file system

How File System Commands Determine the File System Type

The generic file system commands determine the file system type by following this sequence:

1. From the `-F` option, if supplied.
2. By matching a special device with an entry in the `/etc/vfstab` file (if *special* is supplied). For example, `fsck` first looks for a match against the `fsck` device field. If no match is found, it then checks the *special* device field.
3. By using the default specified in the `/etc/default/fs` file for local file systems and in the `/etc/dfs/fstypes` file for remote file systems.

Manual Pages for Generic and Specific Commands

Both the generic commands and specific commands have manual pages in the *man Pages(1M): System Administration Commands*. The manual page for the generic file system commands provide information about generic command options only. The manual page for a specific file system command has specific information about

options for that file system. To look at a specific manual page, append an underscore and the abbreviation for the file system type to the generic command name. For example, to see the specific manual page for mounting a UFS file system, type the following:

```
$ man mount_ufs
```

The Default Solaris File Systems

The Solaris UFS file system is hierarchical, starting with the root directory (/) and continuing downwards through a number of directories. The Solaris installation process enables you to install a default set of directories and uses a set of conventions to group similar types of files together. The following table provides a summary of the default Solaris file systems.

TABLE 38-2 The Default Solaris File Systems

File System or Directory	File System Type	Description
root (/)	UFS	The top of the hierarchical file tree. The root directory contains the directories and files that are critical for system operation, such as the kernel, the device drivers, and the programs used to boot the system. The root directory also contains the mount point directories where local and remote file systems can be attached to the file tree.
/usr	UFS	System files and directories that can be shared with other users. Files that run only on certain types of systems are in the /usr file system (for example, SPARC executables). Files that can be used on all types of systems, such as the man pages, are in the /usr/share directory.
/export/home or /home	NFS, UFS	The mount point for users' home directories, which store user work files. By default the /home directory is an automounted file system. On standalone systems, the /home directory might be a UFS file system on a local disk slice.
/var	UFS	System files and directories that are likely to change or grow over the life of the local system. These include system logs, vi and ex backup files, and uucp files.

TABLE 38-2 The Default Solaris File Systems (Continued)

File System or Directory	File System Type	Description
/opt	NFS, UFS	Optional mount point for third-party software. On some systems, the /opt directory might be a UFS file system on a local disk slice.
/tmp	TMPFS	Temporary files, which are cleared each time the system is booted or the /tmp file system is unmounted.
/proc	PROCFS	A list of active processes, by number.
/etc/mnttab	MNTFS	A file system that provides read-only access to the table of mounted file systems for the local system.
/var/run	TMPFS	A file system for storing temporary files that are not needed after the system is booted.

The root (/) and /usr file systems are needed to run a system. Some of the most basic commands in the /usr file system (like mount) are included in the root (/) file system so that they are available when the system boots or is in single-user mode and /usr is not mounted. For more detailed information on the default directories for the root (/) and /usr file systems, see Chapter 44.

Swap Space

The Solaris operating environment uses some disk slices for temporary storage rather than for file systems. These slices are called *swap* slices, or *swap space*. Swap space is used as virtual memory storage areas when the system does not have enough physical memory to handle current processes.

Since many applications rely on swap space, you should know how to plan for, monitor, and add more swap space when needed. For an overview about swap space and instructions for adding swap space, see Chapter 42.

The UFS File System

UFS is the default disk-based file system in Solaris operating environment. Most often, when you administer a disk-based file system, you will be administering UFS file systems. UFS provides the following features:

UFS Feature	Description
State flags	Show the state of the file system: clean, stable, active, logging, or unknown. These flags eliminate unnecessary file system checks. If the file system is “clean,” “stable,” or “logging,” file system checks are not run.
Extended fundamental types (EFT)	Provides 32-bit user ID (UID), group ID (GID), and device numbers.
Large file systems	Allows files of approximately 1 terabyte in size in a file system that can be up to 16 terabytes in size. You can create a multiterabyte UFS file system on a disk with an EFI disk label.

For detailed information about the UFS file system structure, see Chapter 44.

UFS Logging

UFS logging bundles the multiple metadata changes that make up a complete UFS operation into a transaction. Sets of transactions are recorded in an on-disk log, and then applied to the actual UFS file system’s metadata.

At reboot, the system discards incomplete transactions, but applies the transactions for completed operations. The file system remains consistent because only completed transactions are ever applied. This consistency remains even when a system crashes, which normally interrupts system calls and introduces inconsistencies into a UFS file system.

UFS logging provides two advantages:

- If the file system is already consistent due to the transaction log, you might not have to run the `fsck` command after a system crash or an unclean shutdown. For more information on unclean shutdowns, see “What the `fsck` Command Checks and Tries to Repair” on page 618.
- Can often provide a significant performance improvement because a file system with logging enabled converts multiple updates to the same data into single updates, and so reduces the number of overhead disk operations required.

The log is allocated from free blocks on the file system, and it is sized at approximately 1 Mbyte per 1 Gbyte of file system, up to a maximum of 64 Mbytes. The log is continually flushed as it fills up. The log is also flushed when the file system is unmounted or as a result of any `lockfs` command.

UFS logging is enabled by default on file systems greater than 1 terabyte in size.

If you need to enable UFS logging, specify the `-o logging` option with the `mount` command in the `/etc/vfstab` file or when you mount the file system manually. Logging can be enabled on any UFS file system. Also, the `fsdb` command now has new debugging commands to support UFS logging.

In some operating systems, a file system with logging enabled is known as a *journaling* file system.

Planning UFS File Systems

When laying out file systems, you need to consider possible conflicting demands. Here are some suggestions:

- Distribute the work load as evenly as possible among different I/O systems and disk drives. Distribute the `/export/home` file system and swap space evenly across disks.
- Keep pieces of projects or members of groups within the same file system.
- Use as few file systems per disk as possible. On the system (or boot) disk, you should have three file systems: root (`/`), `/usr`, and swap space. On other disks, create one or, at most, two file systems; one being additional swap space, preferably. Fewer, roomier file systems cause less file fragmentation than many small, over-crowded file systems. Higher-capacity tape drives and the ability of the `ufsdump` command to handle multiple volumes make it easier to back up larger file systems.
- If you have some users who consistently create very small files, consider creating a separate file system with more inodes. However, most sites do not need to keep similar types of user files in the same file system.

For information on default file system parameters as well as procedures for creating new UFS file systems, see Chapter 39.

UFS Direct Input/Output (I/O)

Direct I/O is intended to boost bulk I/O operations. Bulk I/O operations use large buffer sizes to transfer large files (larger than 256 Kbytes).

Using UFS direct I/O might benefit applications, such as database engines, that do their own internal buffering. Starting with the Solaris 8 1/01 release, UFS direct I/O has been enhanced to allow the same kind of I/O concurrency seen when accessing raw devices. Now you can get the benefit of file system naming and flexibility with very little performance penalty. Check with your database vendor to see if they can enable UFS direct I/O in their product configuration options.

Direct I/O can also be enabled on a file system by using the `forcedirectio` option to the `mount` command. Enabling direct I/O is a performance benefit only when a file system is transferring large amounts of sequential data.

When a file system is mounted with this option, data is transferred directly between a user's address space and the disk. When forced direct I/O is not enabled for a file system, data transferred between a user's address space and the disk is first buffered in the kernel address space.

The default behavior is no forced direct I/O on a UFS file system. For more information, see `mount_ufs(1M)`.

Mounting and Unmounting File Systems

Before you can access the files on a file system, you need to mount the file system. When you mount a file system, you attach that file system to a directory (*mount point*) and make it available to the system. The root (/) file system is always mounted. Any other file system can be connected or disconnected from the root (/) file system.

When you mount a file system, any files or directories in the underlying mount point directory are unavailable as long as the file system is mounted. These files are not permanently affected by the mounting process, and they become available again when the file system is unmounted. However, mount directories are typically empty, because you usually do not want to obscure existing files.

For example, the following figure shows a local file system, starting with a root (/) file system and the `sbin`, `etc`, and `opt` subdirectories.

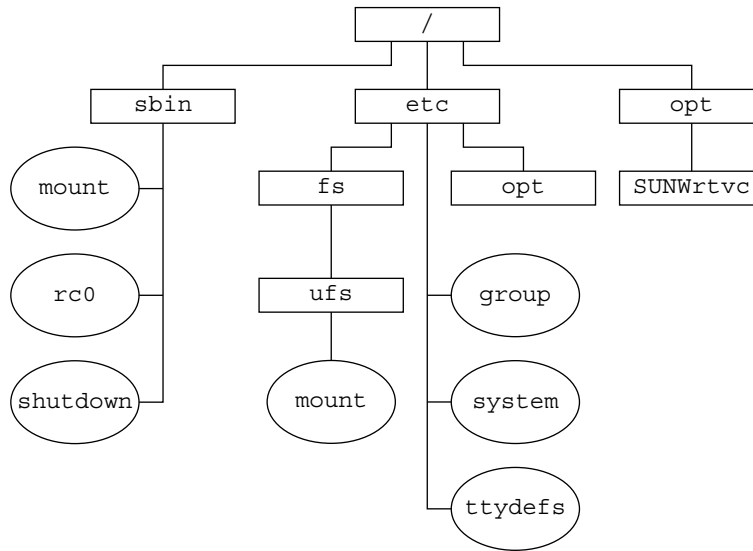
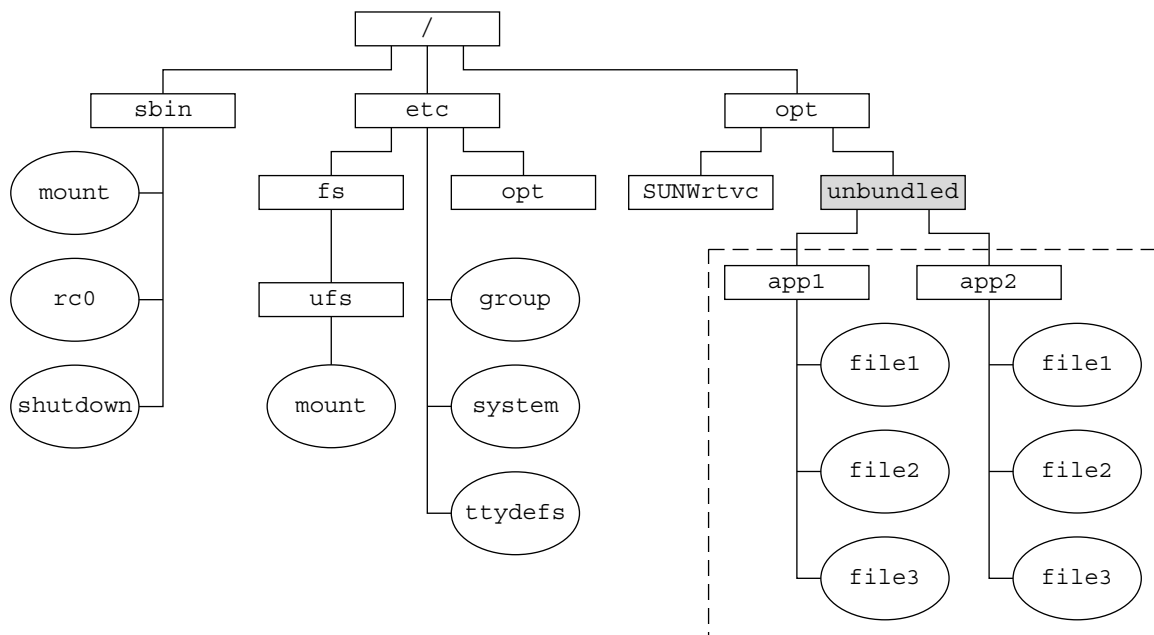

FIGURE 38-1 Sample root (/) File System

To access a local file system from the /opt file system that contains a set of unbundled products, you must do the following:

- First, you must create a directory to use as a mount point for the file system you want to mount, for example, /opt/unbundled.
- Once the mount point is created, you can mount the file system (by using the mount command), which makes all of the files and directories in /opt/unbundled available, as shown in the following figure.

For step-by-step instructions on how to mount file systems, see Chapter 40.



■ Mount point

□ File system

FIGURE 38-2 Mounting a File System

The Mounted File System Table

Whenever you mount or unmount a file system, the `/etc/mnttab` (mount table) file is modified with the list of currently mounted file systems. You can display the contents of this file with the `cat` or `more` commands, but you cannot edit it. Here is an example of an `/etc/mnttab` file:

```

$ more /etc/mnttab
/dev/dsk/c0t0d0s0 / ufs rw,intr,largefiles,onerror=panic,suid,dev=2200000 938557523
/proc /proc proc dev=3180000 938557522
fd /dev/fd fd rw,suid,dev=3240000 938557524
mnttab /etc/mnttab mntfs dev=3340000 938557526
swap /var/run tmpfs dev=1 938557526
swap /tmp tmpfs dev=2 938557529
/dev/dsk/c0t0d0s7 /export/home ufs rw,intr,largefiles,onerror=panic,suid,dev=2200007 ...
$
  
```

The Virtual File System Table

It would be a very time-consuming and error-prone task to manually mount file systems every time you wanted to access them. To avoid this problem, the virtual file system table (the `/etc/vfstab` file) provides a list of file systems and how to mount them.

The `/etc/vfstab` file provides two important features:

- You can specify file systems to automatically mount when the system boots.
- You can mount file systems by using only the mount point name, because the `/etc/vfstab` file contains the mapping between the mount point and the actual device slice name.

A default `/etc/vfstab` file is created when you install a system, depending on the selections you make when installing system software. However, you can edit the `/etc/vfstab` file on a system whenever you want. To add an entry, the main information you need to specify is the device where the file system resides, the name of the mount point, the type of the file system, whether you want the file system to mount automatically when the system boots (by using the `mountall` command), and any mount options.

The following is an example of an `/etc/vfstab` file. Comment lines begin with `#`. This example shows an `/etc/vfstab` file for a system with two disks (`c0t0d0` and `c0t3d0`).

```
$ more /etc/vfstab
#device      device      mount      FS      fsck  mount  mount
#to mount    to fsck     point      type    pass  at boot options
/dev/dsk/c0t0d0s0 /dev/rdisk/c0t0d0s0 /
/proc        -           /proc      proc    -     no     -
/dev/dsk/c0t0d0s1 -           -          swap    -     no     -
swap         -           /tmp       tmpfs   -     yes    -
/dev/dsk/c0t0d0s6 /dev/rdisk/c0t0d0s6 /usr       ufs     2     no     -
/dev/dsk/c0t3d0s7 /dev/rdisk/c0t3d0s7 /test      ufs     2     yes    -
$
```

In the preceding example, the last entry specifies that a UFS file system on the `/dev/dsk/c0t3d0s7` slice will be automatically mounted on the `/test` mount point when the system boots. Note that, for root (`/`) and `/usr`, the `mount at boot` field value is specified as `no`, because these file systems are mounted by the kernel as part of the boot sequence before the `mountall` command is run.

For descriptions of each of the `/etc/vfstab` fields and information on how to edit and use the file, see Chapter 40.

The NFS Environment

NFS is a distributed file system service that can be used to share *resources* (files or directories) from one system, typically a server, with other systems on the network. For example, you might want to share third-party applications or source files with users on other systems.

NFS makes the actual physical location of the resource irrelevant to the user. Instead of placing copies of commonly used files on every system, NFS allows you to place one copy on one system's disk and let all other systems access it from the network. Under NFS, remote files are virtually indistinguishable from local ones.

A system becomes an NFS server if it has resources to share on the network. A server keeps a list of currently shared resources and their access restrictions (such as read/write or read-only access).

When you share a resource, you make it available for mounting by remote systems.

You can share a resource in these ways:

- By using the `share` or `shareall` command
- By adding an entry to the `/etc/dfs/dfstab` (distributed file system table) file and rebooting the system

For information on how to share resources, see Chapter 40. For a complete description of NFS, see “Managing Network File Systems (Overview)” in *System Administration Guide: Resource Management and Network Services*.

Automounting or AutoFS

You can mount NFS file system resources by using a client-side service called automounting (or AutoFS), which enables a system to automatically mount and unmount NFS resources whenever you access them. The resource remains mounted as long as you remain in the directory and are using a file. If the resource is not accessed for a certain period of time, it is automatically unmounted.

AutoFS provides the following features:

- NFS resources don't need to be mounted when the system boots, which saves booting time.
- Users don't need to know the root password to mount and unmount NFS resources.
- Network traffic might be reduced, since NFS resources are only mounted when they are in use.

The AutoFS service is initialized by the `automount` utility, which runs automatically when a system is booted. The `automountd` daemon runs continuously and is responsible for the mounting and unmounting of the NFS file systems on an as-needed basis. By default, the `/home` file system is mounted by the `automount` daemon.

With AutoFS, you can specify multiple servers to provide the same file system. This way, if one of the servers is down, AutoFS can try to mount from another machine.

For complete information on how to set up and administer AutoFS, see *System Administration Guide: IP Services*.

Determining a File System's Type

You can determine a file system's type by using the following:

- The `FS` type field in the virtual file system table (`/etc/vfstab` file)
- The `/etc/default/fs` file for local file systems
- The `/etc/dfs/fstypes` file for NFS file systems

How to Determine a File System's Type

This procedure works whether the file system is mounted or not.

Determine a file system's type by using the `grep` command.

```
$ grep mount-point fs-table
```

mount-point

Specifies the mount point name of the file system for which you want to know the file system type. For example, the `/var` directory.

fs-table

Specifies the absolute path to the file system table in which to search for the file system's type. If the file system is mounted, *fs-table* should be `/etc/mnttab`. If the file system isn't mounted, *fs-table* should be `/etc/vfstab`.

Information for the mount point is displayed.

Note – If you have the raw device name of a disk slice, you can use the `fstyp` command to determine a file system's type (if the disk slice contains a file system). For more information, see `fstyp(1M)`.

Examples—Determining a File System's Type

The following example uses the `/etc/vfstab` file to determine the type of the `/export` file system.

```
$ grep /export /etc/vfstab
/dev/dsk/c0t3d0s6 /dev/rdisk/c0t3d0s6 /export ufs 2 yes -
$
```

The following example uses the `/etc/mnttab` file to determine the file system type of the currently mounted diskette (which was mounted by `vold`).

```
$ grep /floppy /etc/mnttab
/vol/dev/diskette0/unnamed_floppy /floppy/unnamed_floppy pcfs rw,
nohidden,nofoldcase,dev=16c0009 89103376
$
```

Creating File Systems (Tasks)

This chapter describes how to create UFS, temporary (TMPFS), and loopback (LOFS) file systems. For UFS file systems, this chapter shows you how to create a file system on a hard disk by using the `newfs` command. Because TMPFS and LOFS are virtual file systems, you actually “access” them by mounting them.

This is a list of the step-by-step instructions in this chapter.

- “How to Create a UFS File System” on page 552
- “How to Create a TMPFS File System” on page 554
- “How to Create an LOFS File System” on page 556

Note – For instructions on how to create UFS and DOS file systems on removable media, see Chapter 17.

Creating a UFS File System

Before you can create a UFS file system on a disk, the disk must be formatted and divided into slices. A disk slice is a physical subset of a disk that is composed of a single range of contiguous blocks. A slice can be used either as a raw device that provides, for example, swap space, or to hold a disk-based file system. See Chapter 32 for complete information on formatting disks and dividing disks into slices.

Volume management products, like Solaris Volume Manager, create more sophisticated *volumes*, that expand beyond single slice or single disk boundaries. For more information about using volumes, see *Solaris Volume Manager Administration Guide*.

Note – Solaris device names use the term slice (and the letter *s* in the device name) to refer to the slice number. Slices are also called “partitions.”

You need to create UFS file systems only occasionally, because the Solaris operating environment automatically creates them as part of the installation process. You need to create (or re-create) a UFS file system when you want to do the following:

- Add or replace disks
- Change the existing partitioning structure
- Do a full restoration of a file system

The `newfs` command is the standard way to create UFS file systems. The `newfs` command is a convenient front-end to the `mkfs` command, which actually creates the new file system. The `newfs` command reads parameter defaults, such as tracks per cylinder and sectors per track, from the disk label that will contain the new file system. The options you choose are passed to the `mkfs` command to build the file system.

Default Parameters for the `newfs` Command

To make a new file system on a disk slice, you almost always use the `newfs` command. The following table shows the default parameters that are used by the `newfs` command.

Parameter	Default Value
Block size	8 Kbytes
Fragment size	1 Kbyte
Minimum free space	((64 Mbytes/partition size) * 100), rounded down to the nearest integer and limited to between 1% and 10%, inclusively
Rotational delay	Zero
Optimization type	Time
Number of inodes	1 inode for each 2 Kbytes of data space

▼ How to Create a UFS File System

1. **Make sure you have met the following prerequisites:**

- a. **The disk must be formatted and divided into slices.**

For information on formatting disks and dividing disks into slices, see Chapter 32.

- b. **You need to know the device name of the slice that will contain the file system.**

For information on finding disks and disk slice numbers, see Chapter 33.

- c. **If you are re-creating an existing UFS file system, unmount it.**
- d. **You must be superuser or assume an equivalent role.**

2. Create the UFS file system.

```
# newfs [-N] [-b size] [-i bytes] /dev/rdisk/device-name
```

-N	Displays what parameters the <code>newfs</code> command would pass to the <code>mkfs</code> command without actually creating the file system. This option is a good way to test the <code>newfs</code> command.
-b <i>size</i>	Specifies the block size for the file system, either 4096 or 8192 bytes per block. The default is 8192.
-i <i>bytes</i>	Specifies the number of bytes per inode. The default varies depending on the disk size. For more information, see <code>newfs(1M)</code> .
<i>device-name</i>	Specifies the disk device name on which to create the new file system.

The system asks for confirmation.



Caution – Be sure you have specified the correct device name for the slice before performing this step. If you specify the wrong slice, you will erase its contents when the new file system is created. This error might cause the system to panic.

3. To verify the creation of the UFS file system, check the new file system.

```
# fsck /dev/rdisk/device-name
```

The `device-name` argument specifies the name of the disk device that contains the new file system.

The `fsck` command checks the consistency of the new file system, reports any problems, and prompts you before it repairs the problems. For more information on the `fsck` command, see Chapter 43 or `fsck(1M)`.

Example—Creating a UFS File System

The following example shows how to create a UFS file system on `/dev/rdisk/c0t1d0s7`.

```
# newfs /dev/rdisk/c0t1d0s7
/dev/rdisk/c0t1d0s7: 725760 sectors in 720 cylinders of 14 tracks, 72 sectors
    354.4MB in 45 cyl groups (16 c/g, 7.88MB/g, 3776 i/g)
super-block backups (for fsck -F ufs -o b=#) at:
 32, 16240, 32448, 48656, 64864, 81072, 97280, 113488, 129696, 145904, 162112,
178320, 194528, 210736, 226944, 243152, 258080, 274288, 290496, 306704,
322912, 339120, 355328, 371536, 387744, 403952, 420160, 436368, 452576,
468784, 484992, 501200, 516128, 532336, 548544, 564752, 580960, 597168,
613376, 629584, 645792, 662000, 678208, 694416, 710624,
#
```

Where to Go From Here

To mount the UFS file system and make it available, go to Chapter 40.

Creating a Temporary File System (TMPFS)

A temporary file system (TMPFS) uses local memory for file system reads and writes, which is typically much faster than reads and writes in a UFS file system. TMPFS file systems can improve system performance by saving the cost of reading and writing temporary files to a local disk or across the network. Files in TMPFS file systems do not survive across reboots or unmounts.

If you create multiple TMPFS file systems, be aware that they all use the same system resources. Files created under one TMPFS file system use up the space available for any other TMPFS file system, unless you limit TMPFS sizes by using the `-o size` option of the `mount` command.

For more information, see the `tmpfs(7FS)`.

▼ How to Create a TMPFS File System

1. **Become superuser or assume an equivalent role.**
2. **Create the directory that you want to mount as the TMPFS file system, if necessary.**

```
# mkdir /mount-point
```

mount-point is the directory on which the TMPFS file system is mounted.

3. Mount the TMPFS file system.

```
# mount -F tmpfs [-o size=number] swap mount-point
```

-o size=number Specifies the size limit of the TMPFS file system in Mbytes.

mount-point Specifies the directory on which the TMPFS file system is mounted.

To set up the system to automatically mount a TMPFS file system when it boots, see “Example—Mounting a TMPFS File System at Boot Time” on page 555.

4. Verify that the TMPFS file system has been created.

```
# mount -v
```

Example—Creating a TMPFS File System

The following example shows how to create, mount, and limit the size of the TMPFS file system, */export/reports*, to 50 Mbytes.

```
# mkdir /export/reports
# chmod 777 /export/reports
# mount -F tmpfs -o size=50m swap /export/reports
```

Example—Mounting a TMPFS File System at Boot Time

You can set up the system to automatically mount a TMPFS file system when it boots by adding an */etc/vfstab* entry. The following example shows an entry in the */etc/vfstab* file that mounts */export/test* as a TMPFS file system when the system boots. Since the *size=number* option is not specified, the size of the TMPFS file system on */export/test* is limited only by the available system resources.

```
swap - /export/test tmpfs - yes -
```

For more information on the */etc/vfstab* file, see “Field Descriptions for the */etc/vfstab* File” on page 562.

Creating a Loopback File System (LOFS)

A LOFS file system is a virtual file system that provides an alternate path to an existing file system. When other file systems are mounted onto an LOFS file system, the original file system does not change.

For more information, see the `lofs(7FS)`.



Caution – Be careful when creating LOFS file systems. Because LOFS file systems are virtual file systems, the potential for confusing both users and applications is enormous.

▼ How to Create an LOFS File System

1. **Become superuser or assume an equivalent role.**
2. **Create the directory you want to mount as an LOFS file system, if necessary.**

```
# mkdir loopback-directory
```

3. **Grant the appropriate permissions and ownership on the newly created directory.**

4. **Create the mount point where you want to mount the LOFS file system, if necessary.**

```
# mkdir /mount-point
```

5. **Mount the LOFS file system.**

```
# mount -F lofs loopback-directory /mount-point
```

loopback-directory

Specifies the file system to be mounted on the loopback mount point.

/mount-point

Specifies the directory on which to mount the LOFS file system.

6. **Verify that the LOFS file system has been mounted.**

```
# mount -v
```

Example—Creating and Mounting an LOFS File System

The following example illustrates how to create, mount, and test new software in the `/new/dist` directory as a loopback file system without actually having to install it.

```
# mkdir /tmp/newroot
# mount -F lofs /new/dist /tmp/newroot
# chroot /tmp/newroot newcommand
```

Example—Mounting an LOFS File System at Boot Time

You can set up the system to automatically mount an LOFS file system when it boots by adding an entry to the end of the `/etc/vfstab` file. The following example shows an entry in the `/etc/vfstab` file that mounts an LOFS file system for the root (`/`) file system on `/tmp/newroot`.

```
/ - /tmp/newroot lofs - yes -
```



Caution – Make sure the loopback entries are the last entries in the `/etc/vfstab` file. Otherwise, if the `/etc/vfstab` entry for a loopback file system precedes the file systems to be included in it, the loopback file system cannot be mounted.

For more information on the `/etc/vfstab` file, see “Field Descriptions for the `/etc/vfstab` File” on page 562.

Mounting and Unmounting File Systems (Tasks)

This chapter describes how to mount and unmount file systems.

This is a list of the step-by-step instructions in this chapter.

- “How to Determine Which File Systems Are Mounted” on page 564
- “How to Add an Entry to the `/etc/vfstab` File” on page 564
- “How to Mount a File System (`/etc/vfstab` File)” on page 566
- “How to Mount a UFS File System (`mount` Command)” on page 567
- “How to Mount a UFS File System Without Large Files (`mount` Command)” on page 568
- “How to Mount an NFS File System (`mount` Command)” on page 569
- “x86: How to Mount a PCFS (DOS) File System From a Hard Disk (`mount` Command)” on page 570
- “How to Verify a File System is Unmounted” on page 572
- “How to Stop All Processes Accessing a File System” on page 572
- “How to Unmount a File System” on page 573

Overview of Mounting File Systems

After you create a file system, you need to make it available to the system so you can use it. You make a file system available by mounting it, which attaches the file system to the system directory tree at the specified mount point. The root (`/`) file system is always mounted.

The following table provides guidelines on mounting file systems based on how you use them.

Mount Type Needed	Suggested Mount Method
Local or remote file systems that need to be mounted infrequently	The <code>mount</code> command that you enter manually from the command line.
Local file systems that need to be mounted frequently	The <code>/etc/vfstab</code> file, which mounts the file system automatically when the system is booted in multi-user state.
Remote file systems that need to be mounted frequently, such as home directories	<ul style="list-style-type: none"> ■ The <code>/etc/vfstab</code> file, which automatically mounts the file system when the system is booted in multi-user state. ■ AutoFS, which automatically mounts or unmounts the file system when you access or change out of the directory. <p>To enhance performance, you can also cache the remote file systems by using the CacheFS file system.</p>

You can mount media that contains a file system by inserting the media into the drive and running the `volcheck` command if necessary. For more information on mounting removable media, see Chapter 17.

Commands for Mounting and Unmounting File Systems

The following table lists the commands in the `/usr/sbin` directory that you use to mount and unmount file systems.

TABLE 40-1 Commands for Mounting and Unmounting File Systems

Command	Man Page	Description
<code>mount</code>	<code>mount(1M)</code>	Mounts file systems and remote resources.
<code>mountall</code>	<code>mountall(1M)</code>	Mounts all file systems that are specified in the <code>/etc/vfstab</code> file. The <code>mountall</code> command runs automatically when the system enters multiuser mode.
<code>umount</code>	<code>mount(1M)</code>	Unmounts file systems and remote resources.
<code>umountall</code>	<code>mountall(1M)</code>	Unmounts all file systems that are specified in the <code>/etc/vfstab</code> file.

The `mount` and `mountall` commands will not mount a read/write file system that has known inconsistencies. If you receive an error message from the `mount` or `mountall` command, you might need to check the file system. See Chapter 43 for information on how to check the file system.

The `umount` and `umountall` commands will not unmount a file system that is busy. A file system is considered busy if one of the following is true:

- A user is accessing a file or directory in the file system.
- If a program has a file open in that file system.
- If the file system is shared.

Commonly Used Mount Options

The following table describes the commonly used options that you can specify with the `mount -o` option. If you specify multiple options, separate them with commas (no spaces). For example, `-o ro,nosuid`.

For a complete list of mount options for each file system type, refer to the specific mount man pages (for example, `mount_ufs(1M)`).

TABLE 40-2 Commonly Used `-o` Mount Options

Option	File System	Description
<code>bg</code> <code>fg</code>	NFS	If the first mount attempt fails, retries in the background (<code>bg</code>) or in the foreground (<code>fg</code>). This option is safe for non-critical <code>vfstab</code> entries. The default is <code>fg</code> .
<code>hard</code> <code>soft</code>	NFS	Specifies the procedure if the server does not respond. The <code>soft</code> option indicates that an error is returned. The <code>hard</code> option indicates that the retry request is continued until the server responds. The default is <code>hard</code> .
<code>intr</code> <code>nointr</code>	NFS	Specifies whether keyboard interrupts are delivered to a process that is hung while waiting for a response on a hard-mounted file system. The default is <code>intr</code> (interrupts allowed).
<code>largefiles</code> <code>nolargefiles</code>	UFS	Enables you to create files larger than 2 Gbytes. The <code>largefiles</code> option means that a file system mounted with this option <i>might</i> contain files larger than 2 Gbytes, but it is not required. If the <code>nolargefiles</code> option is specified, the file system cannot be mounted on a system that is running Solaris 2.6 or compatible versions. The default is <code>largefiles</code> .

TABLE 40-2 Commonly Used `-o` Mount Options (Continued)

Option	File System	Description
logging nologging	UFS	Enables or disables logging for the file system. UFS logging is the process of storing transactions (changes that make up a complete UFS operation) into a log before the transactions are applied to the UFS file system. Logging helps prevent UFS file systems from becoming inconsistent, which means <code>fsck</code> can be bypassed. Bypassing <code>fsck</code> reduces the time to reboot a system if it crashes, or after a system is shutdown uncleanly. The log is allocated from free blocks on the file system, and is sized at approximately 1 Mbyte per 1 Gbyte of file system, up to a maximum of 64 Mbytes. The default is <code>nologging</code> .
atime noatime	UFS	Suppresses access time updates on files, except when they coincide with updates to the time of the last file status change or the time of the last file modification. For more information, see <code>stat(2)</code> . This option reduces disk activity on file systems where access times are unimportant (for example, a Usenet news spool). The default is normal access time (<code>atime</code>) recording.
remount	All	Changes the mount options associated with an already-mounted file system. This option can generally be used with any option except <code>ro</code> , but what can be changed with this option is dependent on the file system type.
retry= <i>n</i>	NFS	Retries the mount operation when it fails. <i>n</i> is the number of times to retry.
ro rw	CacheFS, NFS, PCFS, UFS, HSFS	Specifies read/write (<code>rw</code>) or read-only (<code>ro</code>). If you do not specify this option, the default is <code>rw</code> . The default option for HSFS is <code>ro</code> .
suid nosuid	CacheFS, HSFS, NFS, UFS	Allows or disallows <code>setuid</code> execution. The default is to allow <code>setuid</code> execution.

Field Descriptions for the `/etc/vfstab` File

An entry in the `/etc/vfstab` file has seven fields, which are described in the following table.

TABLE 40-3 Field Descriptions for the `/etc/vfstab` File

Field Name	Description
<code>device to mount</code>	<p>This field identifies one of the following:</p> <ul style="list-style-type: none"> ■ The block device name for a local UFS file system (for example, <code>/dev/dsk/c0t0d0s0</code>). ■ The resource name for a remote file system (for example, <code>myserver:/export/home</code>). For more information about NFS, see <i>System Administration Guide: IP Services</i>. ■ The block device name of the slice on which to swap (for example, <code>/dev/dsk/c0t3d0s1</code>). ■ A directory for a virtual file system type.
<code>device to fsck</code>	<p>The raw (character) device name that corresponds to the UFS file system identified by the <code>device to mount</code> field (for example, <code>/dev/rdisk/c0t0d0s0</code>). This field determines the raw interface that is used by the <code>fsck</code> command. Use a dash (-) when there is no applicable device, such as for a read-only file system or a remote file system.</p>
<code>mount point</code>	<p>Identifies where to mount the file system (for example, <code>/usr</code>).</p>
<code>FS type</code>	<p>Identifies the type of file system.</p>
<code>fsck pass</code>	<p>The pass number used by the <code>fsck</code> command to decide whether to check a file system. When the field contains a dash (-), the file system is not checked.</p> <p>When the field contains a zero, UFS file systems are not checked but non-UFS file systems are checked. When the field contains a value greater than zero, the file system is always checked.</p> <p>All file systems with a value of 1 in this field are checked one at a time in the order they appear in the <code>vfstab</code> file. When the <code>fsck</code> command is run on multiple UFS file systems that have <code>fsck pass</code> values greater than one and the <code>preen</code> option (<code>-o p</code>) is used, the <code>fsck</code> command automatically checks the file systems on different disks in parallel to maximize efficiency. Otherwise, the value of the pass number does not have any effect.</p>
<code>mount at boot</code>	<p>Set to <code>yes</code> or <code>no</code> for whether the file system should be automatically mounted by the <code>mountall</code> command when the system is booted. Note that this field has nothing to do with AutoFS. The root (<code>/</code>), <code>/usr</code> and <code>/var</code> file systems are not mounted from the <code>vfstab</code> file initially. This field should always be set to <code>no</code> for these file systems and for virtual file systems such as <code>/proc</code> and <code>/dev/fd</code>.</p>
<code>mount options</code>	<p>A list of comma-separated options (with no spaces) that are used for mounting the file system. Use a dash (-) to indicate no options. For a list of commonly used mount options, see Table 40-2.</p>

Note – You must have an entry in each field in the `/etc/vfstab` file. If there is no value for the field, be sure to enter a dash (-). Otherwise, the system might not boot successfully. Similarly, white space should not be used in a field value.

Mounting File Systems

The following sections describe how to mount a file system by adding an entry in the `/etc/vfstab` file or by using the `mount` command from the command line.

How to Determine Which File Systems Are Mounted

You can determine which file systems are already mounted by using the `mount` command.

```
$ mount [ -v ]
```

-v

Displays the list of mounted file systems in verbose mode.

Example—Determining Which File Systems Are Mounted

This example shows how to use the `mount` command to display information about the file systems that are currently mounted.

```
$ mount
/ on /dev/dsk/c0t0d0s0 read/write/setuid/intr/largefiles/xattr/onerror=...
/usr on /dev/dsk/c0t0d0s6 read/write/setuid/intr/largefiles/xattr/...
/proc on /proc read/write/setuid/dev=38c0000 on Sun Feb  2 18:20:07 2003
/etc/mnttab on mnttab read/write/setuid/dev=3980000 on Sun Feb  2 ...
/dev/fd on fd read/write/setuid/dev=39c0000 on Sun Feb  2 18:20:10 2003
/var/run on swap read/write/setuid/xattr/dev=1 on Sun Feb  2 18:20:11 2003
/tmp on swap read/write/setuid/xattr/dev=2 on Sun Feb  2 18:20:15 2003
/export/home on /dev/dsk/c0t0d0s7 read/write/setuid/intr/largefiles/...
$
```

▼ How to Add an Entry to the `/etc/vfstab` File

1. **Become superuser or assume an equivalent role.**
2. **Create a mount point for the file system to be mounted, if necessary.**

```
# mkdir /mount-point
```

There must be a mount point on the local system to mount a file system. A mount point is a directory to which the mounted file system is attached.

3. Edit the `/etc/vfstab` file and add an entry. Make sure that you do the following:

- a. Separate each field with white space (a space or a tab).
- b. Enter a dash (-) if a field has no contents.
- c. Save the changes.

For detailed information about the `/etc/vfstab` field entries, see Table 40–3.

Note – Since the root (`/`) file system is mounted read-only by the kernel during the boot process, only the `remount` option (and options that can be used in conjunction with `remount`) affect the root (`/`) entry in the `/etc/vfstab` file.

Examples—Adding an Entry to the `/etc/vfstab` File

The following example shows how to mount the disk slice `/dev/dsk/c0t3d0s7` as a UFS file system to the mount point directory `/files1`. The raw character device `/dev/rdisk/c0t3d0s7` is specified as the device to `fsck`. The `fsck pass` value of 2 means that the file system will be checked, but not sequentially.

```
#device          device          mount  FS    fsck  mount  mount
#to mount        to fsck          point  type  pass  at boot options
#
/dev/dsk/c0t3d0s7 /dev/rdisk/c0t3d0s7 /files1 ufs    2     yes    -
```

The following example shows how to mount the `/export/man` directory from the system `pluto` as an NFS file system on mount point `/usr/man`. A device to `fsck` nor a `fsck pass` is specified because it's an NFS file system. In this example, mount options are `ro` (read-only) and `soft`.

```
#device          device          mount  FS    fsck  mount  mount
#to mount        to fsck          point  type  pass  at boot options
pluto:/export/man -           /usr/man nfs    -     yes    ro,soft
```

The following example shows how to mount the root (`/`) file system on a loopback mount point, `/tmp/newroot`. LOFS file systems must always be mounted after the file systems that are in the LOFS file system.

```
#device          device          mount  FS    fsck  mount  mount
#to mount        to fsck          point  type  pass  at boot options
#
/                 -              /tmp/newroot lofs  -     yes    -
```

▼ How to Mount a File System (/etc/vfstab File)

1. Become superuser or assume an equivalent role.
2. Mount a file system listed in the /etc/vfstab file.

```
# mount /mount-point
```

/mount-point specifies an entry in the mount point or device to mount field in the /etc/vfstab file. It is usually easier to specify the mount point.

Example—Mounting a File System (/etc/vfstab File)

The following example shows how to mount the /usr/dist file system that is listed in the /etc/vfstab file.

```
# mount /usr/dist
```

Examples—Mounting All File Systems (/etc/vfstab File)

The following example shows the messages that are displayed if file systems are already mounted when you use the mountall command.

```
# mountall
/dev/rdisk/c0t0d0s7 already mounted
mount: /tmp already mounted
mount: /dev/dsk/c0t0d0s7 is already mounted, /export/home is busy,
      or the allowable number of mount points has been exceeded
```

All the file systems with a device to fsck entry are checked and fixed, if necessary, before they are mounted.

The following example shows how to mount all the local systems that are listed in the /etc/vfstab file.

```
# mountall -l
# mount
/ on /dev/dsk/c0t0d0s0 read/write/setuid/intr/largefiles/xattr/onerror=...
/usr on /dev/dsk/c0t0d0s6 read/write/setuid/intr/largefiles/xattr/...
/proc on /proc read/write/setuid/dev=38c0000 on Sun Feb  2 18:20:07 2003
/etc/mnttab on mnttab read/write/setuid/dev=3980000 on Sun Feb  2 ...
/dev/fd on fd read/write/setuid/dev=39c0000 on Sun Feb  2 18:20:10 2003
/var/run on swap read/write/setuid/xattr/dev=1 on Sun Feb  2 18:20:11 2003
/tmp on swap read/write/setuid/xattr/dev=2 on Sun Feb  2 18:20:15 2003
/export/home on /dev/dsk/c0t0d0s7 read/write/setuid/intr/largefiles/xattr...
/datab on /dev/dsk/c0t0d0s7 read/write/setuid/intr/largefiles/xattr/ ...
```

The following example shows how to mount all of the remote file systems that are listed in the /etc/vfstab file.

```
# mountall -r
# mount
/ on /dev/dsk/c0t0d0s0 read/write/setuid/intr/largefiles/xattr/onerror=...
/usr on /dev/dsk/c0t0d0s6 read/write/setuid/intr/largefiles/xattr/...
/proc on /proc read/write/setuid/dev=38c0000 on Sun Feb  2 18:20:07 2003
/etc/mnttab on mnttab read/write/setuid/dev=3980000 on Sun Feb  2 ...
/dev/fd on fd read/write/setuid/dev=39c0000 on Sun Feb  2 18:20:10 2003
/var/run on swap read/write/setuid/xattr/dev=1 on Sun Feb  2 18:20:11 2003
/tmp on swap read/write/setuid/xattr/dev=2 on Sun Feb  2 18:20:15 2003
/export/home on /dev/dsk/c0t0d0s7 read/write/setuid/intr/largefiles/xattr...
/datab on /dev/dsk/c0t0d0s7 read/write/setuid/intr/largefiles/xattr/ ...
/home/rimmer on pluto:/export/home/rimmer remote/read/write/setuid/xattr ...
```

▼ How to Mount a UFS File System (mount Command)

1. Become superuser or assume an equivalent role.
2. Create a mount point for the file system to be mounted, if necessary.

```
# mkdir /mount-point
```

There must be a mount point on the local system to mount a file system. A mount point is a directory to which the mounted file system is attached.

3. Mount the UFS file system.

```
# mount [-o mount-options] /dev/dsk/device-name /mount-point
```

<i>-o mount-options</i>	Specifies mount options that you can use to mount a UFS file system. For a list of options, see Table 40–2 or <code>mount_ufs(1M)</code> .
<i>/dev/dsk/device-name</i>	Specifies the disk device name for the slice that contains the file system (for example, <code>/dev/dsk/c0t3d0s7</code>). To get slice information for a disk, see “How to Display Disk Slice Information” on page 465.
<i>/mount-point</i>	Specifies the directory on which to mount the file system.

Example—Mounting a UFS File System (mount Command)

The following example shows how to mount `/dev/dsk/c0t3d0s7` on the `/files1` directory.

```
# mount /dev/dsk/c0t3d0s7 /files1
```

Example—Mounting a UFS File System With Logging Enabled (mount Command)

UFS logging eliminates file system inconsistency, which can significantly reduce the time of system reboots. The following example shows how to mount `/dev/dsk/c0t3d0s7` on the `/files1` directory with logging enabled.

```
# mount -o logging /dev/dsk/c0t3d0s7 /files1
```

▼ How to Mount a UFS File System Without Large Files (mount Command)

When you mount a file system, the `largefiles` option is selected by default, which enables you to create files larger than 2 Gbytes. Once a file system contains large files, you cannot remount the file system with the `nolargefiles` option or mount it on a system that is running Solaris 2.6 or compatible versions, until you remove any large files and run the `fsck` command to reset the state to `nolargefiles`.

This procedure assumes that the file system is in the `/etc/vfstab` file.

1. **Become superuser or assume an equivalent role.**
2. **Create a mount point for the file system to be mounted, if necessary.**

```
# mkdir /mount-point
```

There must be a mount point on the local system to mount a file system. A mount point is a directory to which the mounted file system is attached.

3. **Make sure there are no large files in the file system.**

```
# cd /mount-point
# find . -xdev -size +20000000 -exec ls -l {} \;
```

`/mount-point` identifies the mount point of the file system you want to check for large files.

4. **Remove or move any large files in this file system to another file system, if necessary.**
5. **Unmount the file system.**

```
# umount /mount-point
```

6. **Reset the file system state.**

```
# fsck /mount-point
```

7. **Remount the file system with the `nolargefiles` option.**

```
# mount -o nolargefiles /mount-point
```

Example—Mounting a File System Without Large Files (mount Command)

The following example shows how to check the /dat`ab` file system and remount it with the `nolargefiles` option.

```
# cd /datab
# find . -xdev -size +20000000 -exec ls -l {} \;
# umount /datab
# fsck /datab
# mount -o nolargefiles /datab
```

▼ How to Mount an NFS File System (mount Command)

1. Become superuser or assume an equivalent role.
2. Create a mount point for the file system to be mounted, if necessary.

```
# mkdir /mount-point
```

There must be a mount point on the local system to mount a file system. A mount point is a directory to which the mounted file system is attached.

3. Make sure the resource (file or directory) is available from a server.

To mount an NFS file system, the resource must be made available on the server by using the `share` command. For information on how to share resources, see “About the NFS Service” in *System Administration Guide: Resource Management and Network Services*.

4. Mount the NFS file system.

```
# mount -F nfs [-o mount-options] server:/directory /mount-point
```

<code>-o mount-options</code>	Specifies mount options that you can use to mount an NFS file system. See Table 40–2 for the list of commonly used mount options or <code>mount_nfs(1M)</code> for a complete list of options.
<code>server:/directory</code>	Specifies the server’s host name that contains the shared resource, and the path to the file or directory to mount.
<code>/mount-point</code>	Specifies the directory on which to mount the file system.

Example—Mounting an NFS File System (mount Command)

The following example shows how to mount the `/export/packages` directory on `/mnt` from the server `pluto`.

```
# mount -F nfs pluto:/export/packages /mnt
```

▼ x86: How to Mount a PCFS (DOS) File System From a Hard Disk (mount Command)

Use the following procedure to mount a PCFS (DOS) file system from a hard disk.

1. **Become superuser or assume an equivalent role.**
2. **Create a mount point for the file system to be mounted, if necessary.**

```
# mkdir /mount-point
```

There must be a mount point on the local system to mount a file system. A mount point is a directory to which the mounted file system is attached.

3. **Mount the PCFS file system.**

```
# mount -F pcfs [-o rw | ro] /dev/dsk/device-name:logical-drive /mount-point
```

<code>-o rw ro</code>	Specifies that you can mount a PCFS file system read/write (rw) or read-only (ro). If you do not specify this option, the default is rw.
<code>/dev/dsk/device-name</code>	Specifies the device name of the whole disk (for example, <code>/dev/dsk/c0t0d0p0</code>).
<code>logical-drive</code>	Specifies either the DOS logical drive letter (c through z) or a drive number (1 through 24). Drive c is equivalent to drive 1 and represents the Primary DOS slice on the drive. All other letters or numbers represent DOS logical drives within the Extended DOS slice.
<code>/mount-point</code>	Specifies the directory on which to mount the file system.

Note that the `device-name` and `logical-drive` must be separated by a colon.

x86: Examples—Mounting a PCFS (DOS) File System From a Hard Disk (mount Command)

The following example shows how to mount the logical drive in the primary DOS slice on the `/pcfs/c` directory.

```
# mount -F pcfs /dev/dsk/c0t0d0p0:c /pcfs/c
```

The following example shows how to mount the first logical drive in the extended DOS slice read-only on /mnt.

```
# mount -F pcfs -o ro /dev/dsk/c0t0d0p0:2 /mnt
```

Unmounting File Systems

The unmounting of a file system removes it from the file system mount point, and deletes the entry from the `/etc/mnttab` file. Some file system administration tasks cannot be performed on mounted file systems. You should unmount a file system when the following occurs:

- The file system is no longer needed or has been replaced by a file system that contains more current software.
- You need to check and repair the file system by using the `fsck` command. For more information about the `fsck` command, see Chapter 43.

It is a good idea to unmount a file system before doing a complete backup. For more information about doing backups, see Chapter 47.

Note – File systems are automatically unmounted as part of the system shutdown procedure.

You can use the `umount -f` option to forcibly unmount a file system that is busy in an emergency situation. This practice is not recommended under normal circumstances because the unmounting of a file system with open files could cause a loss of data. This option is only available for UFS and NFS file systems.

Prerequisites for Unmounting File Systems

The prerequisites for unmounting file systems include the following:

- You must be superuser or assume an equivalent role.
- A file system must be available for unmounting. You cannot unmount a file system that is busy. A file system is considered busy if a user is accessing a directory in the file system, if a program has a file open in that file system, or if it is being shared. You can make a file system available for unmounting by doing the following:
 - Changing to a directory in a different file system.

- Logging out of the system.
- Using the `fuser` command to list all processes that are accessing the file system and to stop them if necessary. For more details, see “How to Stop All Processes Accessing a File System” on page 572.
Notify users if you need to unmount a file system that they are using.
- Unsharing the file system. For information about unsharing a file system, see `unshare(1M)`.

How to Verify a File System is Unmounted

To verify that you unmounted a file system or a number of file systems, examine the output from the `mount` command.

```
$ mount | grep unmounted-file-system
$
```

▼ How to Stop All Processes Accessing a File System

1. **Become superuser or assume an equivalent role.**
2. **List all the processes that are accessing the file system so that you know which processes you are going to stop.**

```
# fuser -c [ -u ] /mount-point
```

<code>-c</code>	Reports on files that are mount points for file systems and any files within those mounted file systems.
<code>-u</code>	Displays the user login name for each process ID.
<code>/mount-point</code>	Specifies the name of the file system for which you want to stop processes.

3. **Stop all processes that are accessing the file system.**

```
# fuser -c -k /mount-point
```

A `SIGKILL` is sent to each process that is using the file system.

Note – You should not stop a user’s processes without first warning the user.

4. **Verify that there are no processes that are accessing the file system.**

```
# fuser -c /mount-point
```

Example—Stopping All Processes Accessing a File System

The following example shows how to stop process 4006c that is using the /export/home file system.

```
# fuser -c /export/home
/export/home:      4006c
# fuser -c -k /export/home
/export/home:      4006c
# fuser -c /export/home
/export/home:
```

▼ How to Unmount a File System

Use the following procedure to unmount a file system, except for the root (/), /usr, or /var file systems.

Note – The root (/), /usr, and /var file systems can be unmounted only during a shutdown, since the system needs these file systems to function.

1. **Make sure that you have met the prerequisites listed in “Prerequisites for Unmounting File Systems” on page 571.**
2. **Unmount the file system.**

```
# umount /mount-point
```

/mount-point is the name of the file system that you want to unmount. This can be one of the following:

- The directory name where the file system is mounted
- The device name path of the file system
- The resource for an NFS file system
- The loopback directory for a LOFS file system

Examples—Unmounting a File System

The following example shows how to unmount a local home file system.

```
# umount /export/home
```

The following example shows how to unmount the file system on slice 7.

```
# umount /dev/dsk/c0t0d0s7
```

The following example shows how to forcibly unmount the /export file system.

```
# umount -f /export
#
```

The following example shows how to unmount all file systems in the `/etc/vfstab` file, except for the root (`/`), `/proc`, `/var`, and `/usr` file systems.

```
# umountall
```

All file systems are unmounted, except for those file systems that are busy.

Using The CacheFS File System (Tasks)

This chapter describes how to set up and maintain CacheFS™ file systems.

This is a list of task maps in this chapter.

- “High-Level View of Using the CacheFS File System (Task Map)” on page 575
- “Creating and Mounting a CacheFS File System (Task Map)” on page 578
- “Maintaining a CacheFS File System (Task Map)” on page 583
- “Packing a Cached File System (Task Map)” on page 589
- “Collecting CacheFS Statistics (Task Map)” on page 598

For information on troubleshooting CacheFS errors, see “Troubleshooting cachefspack Errors” on page 594.

High-Level View of Using the CacheFS File System (Task Map)

Use this task map to identify all the tasks for using CacheFS file systems. Each task in this map points to a series of additional tasks such as creating and mounting the CacheFS file systems, and packing and maintaining the cache.

Task	Description	For Instructions
1. Create and mount a CacheFS file system	Create the cache and mount the file system in the cache.	“Creating and Mounting a CacheFS File System (Task Map)” on page 578

Task	Description	For Instructions
2. Maintain a CacheFS file system	Display and modify a CacheFS file system by unmounting, removing, or re-creating the cache.	"Maintaining a CacheFS File System (Task Map)" on page 583
3. (Optional) Pack and unpack a CacheFS file system	Determine whether you want to pack the cache and use packing lists. Packing the cache ensures that certain files and directories are always updated in the cache.	"Packing a Cached File System (Task Map)" on page 589
4. Collect CacheFS statistics	Determine cache performance and appropriate cache size.	"Collecting CacheFS Statistics (Task Map)" on page 598

Overview of the CacheFS File System

The CacheFS file system is a general purpose caching mechanism that improves NFS server performance and scalability by reducing server and network load. Designed as a layered file system, the CacheFS file system provides the ability to cache one file system on another. In an NFS environment, the CacheFS file system increases the client per server ratio, reduces server and network loads, and improves performance for clients on slow links, such as Point-to-Point Protocol (PPP).

How a CacheFS File System Works

You create a CacheFS file system on a client system so that file systems you cache can be accessed by the client locally instead of across the network. The following figure shows the relationship of the components that are involved in using CacheFS file system.

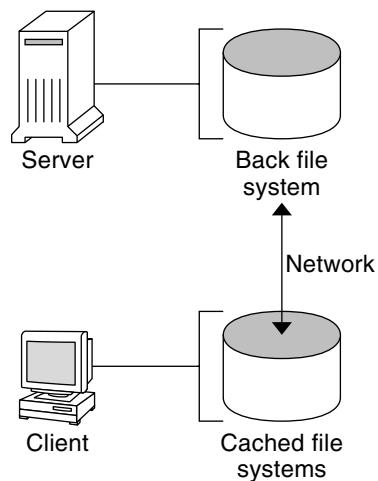

FIGURE 41-1 How a CacheFS File System Works

The *back* file system is the file system that you specify to be mounted in the cache, which can be either NFS or HSFS (High Sierra File System). When the user attempts to access files that are part of the back file system, those files are placed in the cache. The *front* file system is the file system that is mounted in the cache and is accessed from the local mount point. The front file system type must be UFS.

To the user, the initial request to access a file in a CacheFS file system might seem slow, but subsequent uses of the same file are faster.

CacheFS File System Structure and Behavior

Each cache has a set of parameters that determines the cache structure and how it behaves. The parameters are set to default values which are listed in the following table. The default values specify that the entire front file system is used for caching, which is the recommended method of caching file systems.

TABLE 41-1 CacheFS File System Parameters and Their Default Values

CacheFS File System Parameter	Default Value	Definition
maxblocks	90%	Sets the maximum number of blocks that a CacheFS file system is allowed to claim within the front file system.

TABLE 41-1 CacheFS File System Parameters and Their Default Values (Continued)

CacheFS File System Parameter	Default Value	Definition
<code>minblocks</code>	0%	Sets the minimum number of blocks that a CacheFS file system is allowed to claim within the front file system.
<code>threshblocks</code>	85%	Sets the number of blocks that must be available in the front file system before a CacheFS file system can claim more than the blocks specified by <code>minblocks</code> .
<code>maxfiles</code>	90%	Sets the maximum number of available inodes (number of files) that a CacheFS file system is allowed to claim within the front file system.
<code>minfiles</code>	0%	Sets the minimum number of available inodes that a CacheFS file system is allowed to claim within the front file system.
<code>threshfiles</code>	85%	Sets the number of inodes that must be available in the front file system before a CacheFS file system can claim more than the files specified in <code>minfiles</code> .

Typically, you should not change any of these parameter values. They are set to default values to achieve optimal cache behavior. However, you might want to modify the `maxblocks` and `maxfiles` values if you have some room in the front file system that is not used by the cache, and you want to use it for some other file system. You do so by using the `cfsadmin` command. For example:

```
$ cfsadmin -o maxblocks=60
```

Creating and Mounting a CacheFS File System (Task Map)

Use the procedures in this table to create and mount a CacheFS file system.

Task	Description	For Instructions
1. Share the file system to be cached	Verify that the file system you want to cache is shared.	<code>share(1M)</code>

Task	Description	For Instructions
2. Create the cache	Use the <code>cfsadmin</code> command to create the cache.	"How to Create the Cache" on page 579
3. Mount a file system in the cache	<p>Mount a file system in a cache by using one of the following methods:</p> <p>Mount a CacheFS file system by using the <code>mount</code> command.</p> <p>Mount a CacheFS file system by editing the <code>/etc/vfstab</code> file.</p> <p>Mount a cached a file system by using AutoFS.</p>	<p>"How to Mount a CacheFS File System (mount)" on page 580</p> <p>"How to Mount a CacheFS File System (/etc/vfstab)" on page 582</p> <p>"How to Mount a CacheFS File System (AutoFS)" on page 583</p>

▼ How to Create the Cache

1. Become superuser on the client system.
2. Create the cache.

```
# cfsadmin -c /cache-directory
```

cache-directory indicates the name of the directory where the cache resides.

For more information, see `cfsadmin(1M)`.

Note – After you have created the cache, do not perform any operations within the cache directory itself. Doing so could cause conflicts within the CacheFS software.

Example—Creating the Cache

The following example shows how to create a cache in the `/local/mycache` directory by using the default cache parameter values.

```
# mkdir /local
# cfsadmin -c /local/mycache
```

Mounting a File System in the Cache

You specify a file system to be mounted in the cache so that users can locally access files in that file system. The files do not actually get placed in the cache until the user accesses the files.

The following table describes three ways to mount a CacheFS file system.

Mount Type for CacheFS File System	Frequency of CacheFS Mount Type
Using the <code>mount</code> command	Every time the system reboots in order to access the same file system.
Editing the <code>/etc/vfstab</code> file	Only once. The <code>/etc/vfstab</code> file remains unchanged after the system reboots.
Using AutoFS	Only once. AutoFS maps remain unchanged after the system reboots.

Choose the method of mounting file systems that best suits your environment.

You can mount only file systems that are shared. For information on sharing file systems, see `share(1M)`.

Note – The caching of the root (`/`) and `/usr` file systems is not supported in a CacheFS file system.

▼ How to Mount a CacheFS File System (`mount`)

1. **Become superuser on the client system.**

2. **Create the mount point, if necessary.**

```
# mkdir /mount-point
```

You can create the mount point from anywhere but it must be a UFS file system. The CacheFS options used with the `mount` command, as shown in the next step, determine that the mount point you create is cached in the cache directory you specify.

3. **Mount a file system in the cache.**

```
# mount -F cacheFs -o backfstype=fstype,cachedir=/cache-directory [,options]
/back-filesystem /mount-point
```

fstype

Indicates the file system type of the back file system, which can be either NFS or HSFS.

/cache-directory

Indicates the name of the UFS directory where the cache resides. This name is the same name you specified when you created the cache in “How to Create the Cache” on page 579.

<i>options</i>	Specifies other mount options that you can include when you mount a file system in a cache. For a list of CacheFS mount options, see <code>mount_cacheofs(1M)</code> .
<i>/back-filesystem</i>	Specifies the mount point of the back file system to cache. If the back file system is an NFS file system, you must specify the host name of the server from which you are mounting the file system and the name of the file system to cache, separated by a colon. For example, <i>merlin:/data/abc</i> .
<i>/mount-point</i>	Indicates the directory where the file system is mounted.

4. Verify that the cache you created was actually mounted.

```
# cacheofsstat /mount-point
```

The */mount-point* is the CacheFS file system that you created.

For example:

```
# cacheofsstat /docs
/docs
      cache hit rate:    100% (0 hits, 0 misses)
      consistency checks: 1 (1 pass, 0 fail)
      modifies:         0
      garbage collection: 0
```

If the file system was not mounted in the cache, you see an error message similar to the following:

```
# cacheofsstat /mount-point
cacheofsstat: /mount-point: not a cacheofs mountpoint
```

For more information about the `cacheofsstat` command, see “Collecting CacheFS Statistics” on page 598.

Examples—Mounting a CacheFS File System (`mount`)

The following example shows how to mount the NFS file system *merlin:/docs* as a CacheFS file system named */docs* in the cache named */local/mycache*.

```
# mkdir /docs
# mount -F cacheofs -o backfstype=nfs,cachedir=/local/mycache merlin:/docs /docs
```

The following example shows how to make a Solaris 9 SPARC CD (HSFS file system) available as a CacheFS file system named */cfssrc*. Because you cannot write to the CD, the `ro` argument is specified to make the CacheFS file system read-only. This example assumes that `vold` is not running.

```
# mount -F hsfs -o ro /dev/dsk/c0t6d0s0 /sol9
# mount -F cacheofs -o backfstype=hsfs,cachedir=/cfs/cache,ro,noconst,
backpath=/sol9 /dev/dsk/c0t6d0s0 /cfssrc
# ls /cfssrc
Copyright Solaris_9
```

The following example shows how to mount a Solaris 9 SPARC CD as a CacheFS file system with `vold` running.

```
# mount -F cachefs -o backfstype=hsfs,cachedir=/cfs/cache,ro,noconst,  
backpath=/cdrom/sol_9_sparc/s0 /vol/dev/dsk/c0t2d0/sol_9_sparc/s0 /cfssrc
```

The following example shows how to mount a CD as a CacheFS file system with `vold` running.

```
# mount -F cachefs -o backfstype=hsfs,cachedir=/cfs/cache,ro,noconst,  
backpath=/cdrom/epson /vol/dev/dsk/c0t2d0/epson /drvrs
```

The following example uses the `demandconst` option to specify consistency checking on demand for the NFS CacheFS file system `/docs`, whose back file system is `merlin:/docs`. For more information, see “Consistency Checking of a CacheFS File System” on page 586.

```
# mount -F cachefs -o backfstype=nfs,cachedir=/local/mycache,demandconst merlin:/docs /docs
```

▼ How to Mount a CacheFS File System (`/etc/vfstab`)

1. **Become superuser on the client system.**
2. **Using an editor, specify the file systems to be mounted in the `/etc/vfstab` file.**
See the example that follows.
For more information on the `/etc/vfstab` file, see “Field Descriptions for the `/etc/vfstab` File” on page 562.
3. **Mount the CacheFS file system.**

```
# mount /mount-point
```

Or, reboot the system.

Example—Mounting a CacheFS File System (`/etc/vfstab`)

The following example shows the `/etc/vfstab` entry for the `/data/abc` directory from remote system `starbug` that is mounted in the cached directory, `/opt/cache`.

```
#device          device          mount    FS    fsck  mount  mount  
#to mount        to fsck         point    type  pass  at boot options  
#  
starbug:/data/abc /local/abc      /opt/cache cachefs 7    yes    local-access,bg,  
nosuid,demandconst,backfstype=nfs,cachedir=/opt/cache
```

▼ How to Mount a CacheFS File System (AutoFS)

You can mount a file system in a cache with AutoFS by specifying the `-fstype=cachefs` mount option in your automount map. Note that the CacheFS mount options, for example, `backfstype` and `cachedir`, are also specified in the automount map. For details on automount maps, see `automount(1M)`.

1. **Become superuser on the client system.**

2. **Using an editor, add the following line to the `auto_direct` map:**

```
/mount-point -fstype=cachefs, cachedir=/directory, backfstype=nfs
server:/file-system
```

3. **Using an editor, add the following line to the `auto_master` map:**

```
/-
```

The `/-` entry is a pointer to check the `auto_direct` map.

4. **Reboot the system.**

5. **Verify that the entry was made correctly by changing to the file system you mounted in the cache, and then list the contents, as follows:**

```
# cd /filesystem
# ls
```

For more information about AutoFS and how to edit the maps, refer to “Task Overview for Autofs Administration” in *System Administration Guide: Resource Management and Network Services*.

Example—Mounting a CacheFS File System (AutoFS)

The following `auto_direct` entry automatically mounts the CacheFS file system in the `/docs` directory.

```
/docs -fstype=cachefs, cachedir=/local/mycache, backfstype=nfs merlin:/docs
```

Maintaining a CacheFS File System (Task Map)

After a CacheFS file system is set up, it requires little maintenance. Use the optional procedures in this table if you need to perform maintenance tasks on your CacheFS file systems.

Task	Description	For Instructions
1. Modify a CacheFS file system	Modify CacheFS file system behavior by unmounting, deleting, or re-creating the cache.	"Modifying a CacheFS File System" on page 584
2. Display CacheFS file system information	Display information about CacheFS file systems by using the <code>cfsadmin</code> command.	"How to Display Information About a CacheFS File System" on page 585
3. Perform consistency checking	Perform consistency checking on demand by using the <code>cfsadmin</code> command.	"How to Specify Cache Consistency Checking on Demand" on page 586
4. Delete a CacheFS file system	Delete a CacheFS file system by using the <code>umount</code> command and the <code>cfsadmin</code> command.	"How to Delete a CacheFS File System" on page 586
5. Check the integrity of a CacheFS file system	Check the integrity of a CacheFS file system by using the <code>fsck_cacheofs</code> command.	"How to Check the Integrity of a CacheFS File System" on page 588

Maintaining a CacheFS File System

This section describes how to maintain a CacheFS file system.

If you are using the `/etc/vfstab` file to mount file systems, you modify the cache by editing the file system options in the `/etc/vfstab` file. If you are using AutoFS, you modify the cache by editing the file system options in the AutoFS maps.

Modifying a CacheFS File System

When you modify a file system in the cache, you need to delete the cache and then re-create it. You might also need to reboot your machine in single-user mode, depending on how your file systems are shared and accessed.

In the following example, the cache is deleted, re-created, and then mounted again with the `demandconst` option specified for the `/docs` file system.

```
# shutdown -g30 -y
.
.
.
```



```

Type Cntrl-d to proceed with normal startup,
(or give root password for system maintenance):
# enter password:
.
.
.
Here is where you might be prompted to run fsck on the
file system where the cache is located.

# fsck /local
# mount /local
# cfsadmin -d all /local/mycache
# cfsadmin -c /local/mycache
# init 6
.
.
.
console login:
password:
# mount -F cachefs -o backfstype=nfs,cachedir=/local/cache1,demandconst
merlin:/docs /docs
#

```

▼ How to Display Information About a CacheFS File System

1. Become superuser on the client system.
2. Display information about all file systems cached under a specified cache.

```
# cfsadmin -l /cache-directory
```

/cache-directory is the name of the directory where the cache resides.

Example—Displaying Information About CacheFS File Systems

The following example shows information about the `/local/mycache` cache directory. In this example, the `/docs` file system is cached in `/local/mycache`. The last line displays the name of the CacheFS file system.

```
# cfsadmin -l /local/mycache
cfsadmin: list cache FS information
maxblocks      90%
minblocks      0%
threshblocks   85%
maxfiles       90%
minfiles       0%
threshfiles    85%

```

```
maxfilesize      3MB
merlin:_docs:_docs
#
```

Consistency Checking of a CacheFS File System

To ensure that the cached directories and files remain current, the CacheFS software periodically checks the consistency of files stored in the cache. To check consistency, the CacheFS software compares the current modification time to the previous modification time. If the modification times are different, all data and attributes for the directory or file are purged from the cache. And, new data and attributes are retrieved from the back file system.

Consistency Checking on Demand

Consistency checks can be performed only when you explicitly request checks for file systems that are mounted with `-o demandconst` option. If you mount a file system in a cache with this option, then use the `cfsadmin` command with the `-s` option to request a consistency check. By default, consistency checking is performed file by file as the files are accessed. If no files are accessed, no checks are performed. Using the `-o demandconst` option avoids the situation where the network is flooded with consistency checks.

For more information, see `mount_cachefs(1M)`.

▼ How to Specify Cache Consistency Checking on Demand

1. **Become superuser on the client system.**
2. **Mount the file system in the cache and specify cache consistency checking.**

```
# mount -F cachefs -o backfstype=nfs,cachedir=/directory,demandconst
server:/file-system /mount-point
```

3. **Initiate consistency checking on a specific CacheFS file system.**

```
# cfsadmin -s /mount-point
```

▼ How to Delete a CacheFS File System

1. **Become superuser on the client system.**
2. **Unmount the CacheFS file system.**

```
# umount /mount-point
```

/mount-point specifies the CacheFS file system that you want to delete.

3. Determine the name of the CacheFS file system (cache ID).

```
# cfsadmin -l /cache-directory
cfsadmin: list cache FS information
  maxblocks      90%
  minblocks      0%
  threshblocks   85%
  maxfiles       90%
  minfiles       0%
  threshfiles    85%
  maxfilesize    3MB
cache-ID
#
```

4. Delete the CacheFS file system from the specified cache.

```
# cfsadmin -d cache-ID /cache-directory
```

cache-ID Indicates the name of the CacheFS file system, which is the last line of the `cfsadmin -l` output. For more information, see “How to Display Information About a CacheFS File System” on page 585. You can delete all the CacheFS file systems in a particular cache by specifying `all` for *cache-ID*.

/cache-directory Specifies the directory where the cache resides.

5. Verify that the file system has been deleted.

The cache ID of the file system you just deleted should be missing from the `cfsadmin -l` output.

```
# cfsadmin -l /cache-directory
cfsadmin: list cache FS information
  maxblocks      90%
  minblocks      0%
  threshblocks   85%
  maxfiles       90%
  minfiles       0%
  threshfiles    85%
  maxfilesize    3MB
#
```

For more information about the fields that are specified in the command output, refer to `cfsadmin(1M)`.

6. Update the resource counts for the cache by running the `fsck -F cachefs` command.

For more information, see “How to Check the Integrity of a CacheFS File System” on page 588.

Examples—Deleting a CacheFS File System

The following example shows how to delete the file systems from the cache.

```
# umount /cfssrc
# cfsadmin -l /cfssrc
# cfsadmin -d _dev_dsk_c0t6d0s0:_cfssrc
# cfsadmin -l
```

▼ How to Check the Integrity of a CacheFS File System

Use the `fsck` command to check the integrity of CacheFS file systems. The CacheFS version of the `fsck` command automatically corrects problems without requiring user interaction. You should not need to run the `fsck` command manually for CacheFS file systems because the `fsck` command is run automatically at boot time or when the file system is mounted. If you want to manually check the integrity, you can use the following procedure.

For more information, see `fsck_cachefs(1M)`.

1. **Become superuser on the client system.**
2. **Check the file systems in the specified cache.**

```
# fsck -F cachefs [-m -o noclean] /cache-directory
```

<code>-m</code>	Causes the <code>fsck</code> command to check a CacheFS file system without making any repairs.
<code>-o noclean</code>	Forces a check on the CacheFS file systems only. Does not make any repairs.
<code>/cache-directory</code>	Indicates the name of the directory where the cache resides.

Example—Checking the Integrity of CacheFS File Systems

The following example shows how to check the file systems cached in the `/local/mycache` cache.

```
# fsck -F cachefs /local/mycache
#
```

Packing a Cached File System (Task Map)

The following task map describes the procedures that are associated with packing a CacheFS file system. All of these procedures are optional.

Task	Description	For Instructions
Pack files in the cache	Identify files and directories to be loaded in the cache and pack them. Packing ensures that current copies of these files are available in the cache.	"How to Pack Files in the Cache" on page 590
Create a packing list	Create a packing list if you do not want to specify each individual file that you want packed in the cache.	"How to Create a Packing List" on page 592
Pack files in the cache with a packing list	Specify the name of the packing list of the files to be packed in the cache.	"How to Pack Files in the Cache With a Packing List" on page 593
Unpack files or packing lists from the cache	Remove a file from the cache that is no longer needed.	"How to Unpack Files or Packing Lists From the Cache" on page 593
Display packed files information	View information about the files that you've packed, including their packing status.	"How to Display Packed Files Information" on page 591

Packing a CacheFS File System

For general use, the CacheFS software operates automatically after it is set up, without requiring any action from the user. Files are cached on a most recently used basis. With the *packing* feature, you can take a more active role in managing your cache by ensuring that certain files or directories are always updated in the cache.

You can specify files and directories to be loaded in the cache with the `cachefspack` command. This command ensures that current copies of these files are available in the cache.

The *packing list* contains the names of specific files and directories. The packing list can also contain other packing lists. This feature saves you having to specify individual files and directories when you have many items to pack in your cache.

You can print out a brief help summary of all the `cachefspack` options by using the `-h` option as follows:

```
$ cachefspack -h
Must select 1 and only 1 of the following 5 options
-d Display selected filenames
-i Display selected filenames packing status
-p Pack selected filenames
-u Unpack selected filenames
-U Unpack all files in directory 'dir'
-f Specify input file containing rules
-h Print usage information
-r Interpret strings in LIST rules as regular expressions
-s Strip './' from the beginning of a pattern name
-v Verbose option
files - a list of filenames to be packed/unpacked
```

How to Pack Files in the Cache

Pack files in the cache by using the `cachefspack` command.

```
$ cachefspack -p filename
```

<code>-p</code>	Specifies that you want the file or files to be packed. This option is also the default.
<code>filename</code>	Specifies the name of the files or directory you want packed in the cache. When you specify a directory, all of its subdirectories are also packed. For more information, see <code>cachefspack(1M)</code> .

Examples—Packing Files in the Cache

The following example shows the `projects` file being packed in the cache.

```
$ cachefspack -p projects
```

The following example shows three files being packed in the cache.

```
$ cachefspack -p projects updates master_plan
```

The following example shows a directory being packed in the cache.

```
$ cachefspack -p /data/abc/bin
```

How to Display Packed Files Information

Display packed files information by using the `cachefspack -i` command.

```
$ cachefspack -i[v] filename
```

<code>-i</code>	Specifies that you want to view information about your packed files.
<code>-v</code>	Is the verbose option.
<i>cached-filename-or-directory</i>	Specifies the name of the file or directory for which to display information.

Example—Displaying Packed Files Information

The following example shows that the `doc_file` file is successfully packed.

```
$ cachefspack -i doc_file  
cachefspack: file doc_file marked packed YES, packed YES
```

In the following example, the `/data/abc` directory contains the `bin` subdirectory. The `bin` subdirectory has three files: `big`, `medium`, and `small`. Although the `big` and `small` files are specified to be packed, they are not. The `medium` file is successfully packed.

```
$ cd /data/abc  
$ cachefspack -i bin  
.  
.  
.  
cachefspack: file /bin/big marked packed YES, packed NO  
cachefspack: file /bin/medium marked packed YES,  
packed YES  
cachefspack: file /bin/small marked packed YES,  
packed NO  
.  
.  
.
```

If you use the `-iv` options together, you get additional information as to whether the file or directory specified has been flushed from the cache. For example:

```
$ cd /data/bin  
$ cachefspack -iv bin  
.  
.  
.  
cachefspack: file /bin/big marked packed YES, packed NO,  
nocache YES  
cachefspack: file /bin/medium marked packed YES,  
packed YES, nocache NO
```

```
cachefspack: file /bin/small marked packed YES,  
packed NO  
nocache NO  
.  
.  
.
```

The last line of the preceding example shows that the directory contents have not been flushed from the cache.

Using Packing Lists

One feature of the `cachefspack` command is the ability to create packing lists.

A packing list contains files or directories to be packed in the cache. If a directory is in the packing list, all of its subdirectories and files will also be packed.

This feature saves the time of having to specify each individual file that you want packed in the cache.

How to Create a Packing List

To create a packing list, open a file by using `vi` or the editor of your choice. The packing list file format uses the same format as the `filesync` command. For more information, see `filesync(1)`.

Two packing list features are the following:

- You can identify files in the packing list as regular expressions rather than literal file names so that you don't have to specify each individual file name.
- You can pack files from a shared directory by ensuring that you pack only those files that you own.

For more information on using these features, see `cachefspack(1M)`.

Example—Creating a Packing List

The following example shows the contents of a packing list file.

```
BASE /home/ignatz  
LIST plans  
LIST docs  
IGNORE *.ps
```

- The path identified with the `BASE` statement is the directory where you have items you want to pack.

- The two `LIST` statements identify specific files within that directory to pack.
- The `IGNORE` statement identifies the file type of `.ps`, which you do not want to pack.

How to Pack Files in the Cache With a Packing List

Pack files in the packing list by using the `cachefspack -f` command, as follows:

```
$ cachefspack -f packing-list
```

`-f` Specifies that you want to use a packing list.

`packing-list` Specifies the name of the packing list.

Example—Packing Files in the Cache With a Packing List

This example uses the `list.pkg` file as the packing list for the `cachefspack` command.

```
$ cachefspack -f list.pkg
```

Unpacking Files or Packing Lists From the Cache

You might need to remove, or unpack, a file from the cache. Perhaps you have some files or directories that have a higher priority than others, so you need to unpack the less critical files. For example, you finished up a project and have archived the files that are associated with that project. You are now working on a new project, and therefore, a new set of files.

How to Unpack Files or Packing Lists From the Cache

Unpack files or packing lists from the cache by using the `-u` or `-U` option of the `cachefspack` command.

```
$ cachefspack -u filename | -U cache-directory
```

`-u` Specifies that you want the file or files unpacked. You must specify a filename with this option.

<i>filename</i>	Specifies the name of the file or packing list that you want unpacked in the cache.
-U	Specifies that you want to unpack all files in the cache.

For more information about the `cachefspack` command, see the man page.

Examples—Unpacking Files or Packing Lists From the Cache

The following example shows the file `/data/abc/bin/big` being unpacked from the cache.

```
$ cachefspack -u /data/abc/bin/big
```

The following example shows several files being unpacked from the cache.

```
$ cd /data/abc/bin/big
$ cachefspack -u big small medium
```

The following example shows how to unpack a packing list, which is a file that contains the path to a directory of files, as follows:

```
$ cachefspack -uf list.pkg
```

The following example uses the `-U` option to specify that all files in a cache directory being unpacked.

```
$ cachefspack -U /local/mycache
```

You cannot unpack a cache that does not have at least one file system mounted. With the `-U` option, if you specify a cache that does not contain mounted file systems, you see output similar to the following:

```
$ cachefspack -U /local/mycache
cachefspack: Could not unpack cache /local/mycache, no mounted
filesystems in the cache.
```

Troubleshooting `cachefspack` Errors

You might see the following error messages when you use the `cachefspack` command.

```
cachefspack: pathname - can't open directory: permission denied
```

Cause

You might not have the correct permissions to access the file or directory.

Action

Set the correct permissions.

cachefspack: *pathname* - can't open directory: no such file or directory

Cause

You might not have the correct file or directory.

Action

Check for a possible typo.

cachefspack: *pathname* - can't open directory: stale NFS file handle

Cause

The file or directory might have been moved or deleted from the server at the time you attempted to access it.

Action

Verify that the file or directory on the server is still accessible.

cachefspack: *pathname* - can't open directory: interrupted system call

Cause

You might have inadvertently pressed Control-C while issuing the command.

Action

Reissue the command.

cachefspack: *pathname* - can't open directory: I/O error

Cause

You might have a hardware problem.

Action

Check your hardware connections.

cachefspack: error opening dir

Cause

You might not have the correct file or directory. The path identified after the BASE command in the file format could be a file and not a directory. The path specified must be a directory.

Action

Check for a possible typo. Check the path identified after the BASE command in your file format. Make sure the path identifies a directory, not a file.

cachefspack: unable to get shared objects

Cause

The executable might be corrupt or in a format that is not recognizable.

Action

Replace the executable.

cachefspack: *filename* - can't pack file: permission denied

Cause

You might not have the correct permissions to access the file or directory.

Action

Set the correct permissions.

```
cachefspack: filename - can't pack file: no such file or directory
```

Cause

You might not have the correct file or directory.

Action

Check for a possible typo.

```
cachefspack: filename- can't pack file: stale NFS file handle
```

Cause

The file or directory might have been moved or deleted from the server at the time you attempted to access it.

Action

Verify that the file or directory on the server is still accessible.

```
cachefspack: filename- can't pack file: interrupted system call
```

Cause

You might have inadvertently pressed Control-C while issuing the command.

Action

Reissue the command.

```
cachefspack: filename- can't pack file: I/O error
```

Cause

You might have a hardware problem.

Action

Check your hardware connections.

```
cachefspack: filename- can't pack file: no space left on device.
```

Cause

The cache is out of disk space.

Action

You need to increase the size of the cache by increasing disk space.

```
cachefspack: filename - can't unpack file: permission denied
```

Cause

You might not have the correct permissions to access the file or directory.

Action

Set the correct permissions.

```
cachefspack: filename - can't unpack file: no such file or directory
```

Cause

You might not have the correct file or directory.

Action

Check for a possible typo.

```
cachefspack: filename- can't unpack file: stale NFS file handle
```

Cause

The file or directory might have been moved or deleted from the server at the time you attempted to access it.

Action

Verify that the file or directory on the server is still accessible.

```
cachefspack: filename - can't unpack file: interrupted system call
```

Cause

You might have pressed Control-C inadvertently while issuing the command.

Action

Reissue the command.

```
cachefspack: filename- can't unpack file I/O error
```

Cause

You might have a hardware problem.

Action

Check your hardware connections.

```
cachefspack: only one 'd', 'i', 'p', or 'u' option allowed
```

Cause

You entered more than one of these options in a command session.

Action

Select one option for the command session.

```
cachefspack: can't find environment variable.
```

Cause

You forgot to set a corresponding environment variable to match the \$ in your configuration file.

Action

Define the environment variable in the proper location.

```
cachefspack: skipping LIST command - no active base
```

Cause

A LIST command is present in your configuration file that has no corresponding BASE command.

Action

Define the BASE command.

Collecting CacheFS Statistics (Task Map)

The following task map shows the steps involved in collecting CacheFS statistics. All the procedures in this table are optional.

Task	Description	For Instructions
Set up logging	Set up logging on a CacheFS file system using the <code>cachefslog</code> command.	"How to Set Up CacheFS Logging" on page 600
Locate the log file	Locate the log file with the <code>cachefslog</code> command.	"How to Locate the CacheFS Log File" on page 600
Stop logging	Stop logging with the <code>cachefslog</code> command.	"How to Stop CacheFS Logging" on page 601
View the cache size	View the cache size by using the <code>cachefswssize</code> command.	"How to View the Working Set (Cache) Size" on page 601
View the cache statistics	View the statistics by using the <code>cachefsstat</code> command.	"How to View CacheFS Statistics" on page 602

Collecting CacheFS Statistics

Collecting CacheFS statistics enable you to do the following:

- Determine an appropriate cache size
- Observe the performance of the cache

These statistics will help you determine the trade-off between your cache size and the desired performance of the cache.

The CacheFS statistics commands consist of the following:

Command	Man Page	Description
<code>cachefslog</code>	<code>cachefslog(1M)</code>	Specifies the location of the log file. This command also displays where the statistics are currently being logged, and enables you to stop logging.
<code>cachefswssize</code>	<code>cachefswssize(1M)</code>	Interprets the log file to give a recommended cache size.
<code>cachefsstat</code>	<code>cachefsstat(1M)</code>	Displays statistical information about a specific file system or all CacheFS file systems. The information provided in the output of this command is taken directly from the cache.

Note – You can issue the CacheFS statistics commands from any directory. You must be superuser to issue the `cachefswssize` command.

The CacheFS statistics begin accumulating when you create the log file. When the work session is over, stop the logging by using the `cachefslog -h` command, as described in “How to Stop CacheFS Logging” on page 601.

Before using the CacheFS statistics commands, you must do the following:

- Set up your cache by using the `cfsadmin` command.
- Decide on an appropriate length of time to allow statistical information to collect in the log file you create. The length of time should equal a typical work session. For example, a day, a week, or a month.
- Select a location or path for the log file. Make sure that there is enough space to allow for the growth of the log file. The longer you intend to allow statistical information to collect in the log file, the more space you need.

Note – The following procedures are presented in a recommended order. The order is not required.

How to Set Up CacheFS Logging

1. Set up logging.

```
$ cachefslog -f log-file-path /mount-point
```

<i>-f</i>	Sets up logging.
<i>log-file-path</i>	Specifies the location of the log file. The log file is a standard file you create with an editor, such as vi.
<i>/mount-point</i>	Designates the mount point (CacheFS file system) for which statistics are being collected.

2. Verify that you correctly set up the log file.

```
$ cachefslog /mount-point
```

Example—Setting Up CacheFS Logging

The following example shows how to set up the `/var/tmp/samlog` log file to collect statistics about the `/home/sam` directory.

```
$ cachefslog -f /var/tmp/samlog /home/sam  
/var/tmp/samlog: /home/sam
```

How to Locate the CacheFS Log File

You can also use the `cachefslog` command with no options to locate a log file for a particular mount point.

```
$ cachefslog /mount-point
```

/mount-point specifies the CacheFS file system for which you want to view the statistics.

The following example shows what you would see if a log file has been set up. The location of the log file is `/var/tmp/stufflog`.

```
$ cachefslog /home/stuff  
/var/tmp/stufflog: /home/stuff
```

The following example shows that no log file has been set up for the specified file system.

```
$ cachefslog /home/zap  
not logged: /home/zap
```

How to Stop CacheFS Logging

Use the `cachefslog -h` option to stop logging.

```
$ cachefslog -h /mount-point
```

The following example shows how to stop logging on `/home/stuff`.

```
$ cachefslog -h /home/stuff
not logged: /home/stuff
```

If you get a system response other than the one specified here, you did not successfully stop logging. Check to see if you are using the correct log file name and mount point.

How to View the Working Set (Cache) Size

You might want to check if you need to increase the size of the cache. Or, you might want to determine what the ideal cache size is based on your activity since you last used the `cachefslog` command for a particular mount point.

1. **Become superuser on the client system.**
2. **View the current cache size and highest logged cache size.**

```
# cachefswssize log-file-path
For more information, see cachefswssize(1M).
```

Example—Viewing the Working Set (Cache) Size

In the following example, the `end size` is the size of the cache at the time you issued the `cachefswssize` command. The `high water size` is the largest size of the cache during the time frame in which logging occurred.

```
# cachefswssize /var/tmp/samlog

/home/sam
    end size: 10688k
    high water size: 10704k

/
    end size: 1736k
    high water size: 1736k

/opt
    end size: 128k
    high water size: 128k

/nfs/saturn.dist
    end size: 1472k
```

```

high water size: 1472k

/data/abc
  end size: 7168k
high water size: 7168k

/nfs/venus.svr4
  end size: 4688k
high water size: 5000k

/data
  end size: 4992k
high water size: 4992k

total for cache
  initial size: 110960k
  end size: 30872k
high water size: 30872k

```

Viewing CacheFS Statistics

You might want to view certain information about a specific CacheFS file system. The following table explains the terminology that is displayed in the statistics output.

TABLE 41-2 CacheFS Statistics Terminology

Output Term	Description
cache hit rate	The rate of cache hits versus cache misses, followed by the actual number of hits and misses. A cache hit occurs when the user wants to perform an operation on a file or files, and the file or files are actually in the cache. A cache miss occurs when the file is not in the cache. The load on the server is the sum of cache misses, consistency checks, and modifications (modifies).
consistency checks	The number of consistency checks performed, followed by the number that passed, and the number that failed.
modifies	The number of modify operations. For example, writes or creates.

How to View CacheFS Statistics

View the statistics with the `cachefsstat` command. You can view the statistics at any time. For example, you do not have to set up logging in order to view the statistics.

```
$ cachefsstat /mount-point
```

`/mount-point` specifies the CacheFS file system for which you want to view the statistics.

If you do not specify the mount point, statistics for all mounted CacheFS file systems will be displayed.

For more information, see `cachefsstat(1M)`.

Example—Viewing CacheFS Statistics

This example shows how to view statistics on the cached file system, `/home/sam`.

```
$ cachefsstat /home/sam
    cache hit rate: 73% (1234 hits, 450 misses)
    consistency checks: 700 (650 pass, 50 fail)
        modifies: 321
garbage collection: 0
```

Configuring Additional Swap Space (Tasks)

This chapter provides guidelines and step-by-step instructions for configuring additional swap space after the Solaris release is installed.

This is a list of step-by-step instructions in this chapter.

- “How to Create a Swap File and Make It Available” on page 612
- “How to Remove Unneeded Swap Space” on page 613

This is a list of the overview information in this chapter.

- “About Swap Space” on page 605
- “How Do I Know If I Need More Swap Space?” on page 607
- “How Swap Space Is Allocated” on page 608
- “Planning for Swap Space” on page 609
- “Monitoring Swap Resources” on page 610
- “Adding More Swap Space” on page 611

About Swap Space

System administrators should understand the features of the SunOS swap mechanism to determine the following:

- Swap space requirements
- The relationship between swap space and the TMPFS file system
- Recovery from error messages related to swap space

Swap Space and Virtual Memory

The Solaris software uses some disk slices for temporary storage rather than for file systems. These slices are called *swap* slices. Swap slices are used as virtual memory storage areas when the system does not have enough physical memory to handle current processes.

The virtual memory system maps physical copies of files on disk to virtual addresses in memory. Physical memory pages that contain the data for these mappings can be backed by regular files in the file system, or by swap space. If the memory is backed by swap space it is referred to as *anonymous* memory because there is no identity assigned to the disk space that is backing the memory.

The Solaris environment uses the concept of *virtual swap space*, a layer between anonymous memory pages and the physical storage (or disk-backed swap space) that actually back these pages. A system's virtual swap space is equal to the sum of all its physical (disk-backed) swap space plus a portion of the currently available physical memory.

Virtual swap space has these advantages:

- The need for large amounts of physical swap space is reduced because virtual swap space does not necessarily correspond to physical (disk) storage.
- A pseudo file system called SWAPFS provides addresses for anonymous memory pages. Because SWAPFS controls the allocation of memory pages, it has greater flexibility in deciding what happens to a page. For example, SWAPFS might change the page's requirements for disk-backed swap storage.

Swap Space and the TMPFS File System

The TMPFS file system is activated automatically in the Solaris environment by an entry in the `/etc/vfstab` file. The TMPFS file system stores files and their associated information in memory (in the `/tmp` directory) rather than on disk, which speeds access to those files. This feature results in a major performance enhancement for applications such as compilers and DBMS products that use `/tmp` heavily.

The TMPFS file system allocates space in the `/tmp` directory from the system's swap resources. This feature means that as you use up space in the `/tmp` directory, you are also using up swap space. So if your applications use the `/tmp` directory heavily and you do not monitor swap space usage, your system could run out of swap space.

Use the following if you want to use TMPFS but your swap resources are limited:

- Mount the TMPFS file system with the `size` option (`-o size`) to control how much swap resources TMPFS can use.
- Use your compiler's `TMPDIR` environment variable to point to another larger directory.

Using your compiler's `TMPDIR` variable only controls whether the compiler is using the `/tmp` directory. This variable has no effect on other programs' use of the `/tmp` directory.

Swap Space as a Dump Device

A dump device is usually disk space that is reserved to store system crash dump information. By default, a system's dump device is configured to be an appropriate swap partition. If possible, you should configure a alternate disk partition as a *dedicated dump device* instead to provide increased reliability for crash dumps and faster reboot time after a system failure. You can configure a dedicated dump device by using the `dumpadm` command. For more information, see "Managing System Crash Information (Tasks)" in *System Administration Guide: Advanced Administration*.

If you are using a volume manager to manage your disks, such as Solaris Volume Manager, do not configure your dedicated dump device to be under the control of Solaris Volume Manager. You can keep your swap areas under Solaris Volume Manager's control, which is a recommended practice. However, for accessibility and performance reasons, configure another disk as a dedicated dump device outside of Solaris Volume Manager's control.

How Do I Know If I Need More Swap Space?

Use the `swap -l` command to determine if your system needs more swap space.

For example, the following `swap -l` output shows that this system's swap space is almost entirely consumed or at 100% allocation.

```
% swap -l
swapfile          dev  swaplo blocks   free
/dev/dsk/c0t0d0s1 136,1    16 1638608    88
```

When a system's swap space is at 100% allocation, an application's memory pages become temporarily locked. Application errors might not occur, but system performance will likely suffer.

For information on adding more swap space to your system, see "How to Create a Swap File and Make It Available" on page 612.

Swap-Related Error Messages

These messages indicate that an application was trying to get more anonymous memory, and there was no swap space left to back it.

```
application is out of memory
```

```
malloc error 0
```

```
messages.1:Sep 21 20:52:11 mars genunix: [ID 470503 kern.warning]  
WARNING: Sorry, no swap space to grow stack for pid 100295 (myprog)
```

TMPFS-Related Error Messages

The following message is displayed if a page could not be allocated when writing a file. This problem can occur when TMPFS tries to write more than it is allowed or if currently executed programs are using a lot of memory.

```
directory: File system full, swap space limit exceeded
```

The following message means TMPFS ran out of physical memory while attempting to create a new file or directory.

```
directory: File system full, memory allocation failed
```

For information on recovering from the TMPFS-related error messages, see TMPFS(7FS).

How Swap Space Is Allocated

Initially, swap space is allocated as part of the Solaris installation process. If you use the installation program's automatic layout of disk slices and do not manually change the size of the swap slice, the Solaris installation program allocates a default swap area of 512 Mbytes.

Starting in the Solaris 9 release, the installation program allocates swap space starting at the first available disk cylinder (typically cylinder 0). This placement provides maximum space for the root (/) file system during the default disk layout and enables the growth of the root (/) file system during an upgrade.

For general guidelines on allocating swap space, see "Planning for Swap Space" on page 609.

You can allocate additional swap space to the system by creating a swap file. For information about creating a swap file, see "Adding More Swap Space" on page 611.

The /etc/vfstab File

After the system is installed, swap slices and swap files are listed in the `/etc/vfstab` file. They are activated by the `/sbin/swapadd` script when the system is booted.

An entry for a swap device in the `/etc/vfstab` file contains the following:

- The full path name of the swap slice or swap file
- File system type of swap

The file system that contains a swap file must be mounted before the swap file is activated. So, in the `/etc/vfstab` file, make sure that the entry that mounts the file system comes before the entry that activates the swap file.

Planning for Swap Space

The most important factors in determining swap space size are the requirements of the system's software applications. For example, large applications such as computer-aided-design simulators, database-management products, transaction monitors, and geologic analysis systems can consume as much as 200-1000 Mbytes of swap space.

Consult your application vendor for swap space requirements for their applications.

If you are unable to determine swap space requirements from your application vendor, use the following general guidelines based on your system type to allocate swap space:

System Type	Swap Space Size	Dedicated Dump Device Size
Workstation with approximately 4 Gbytes of physical memory	1 Gbyte	1 Gbyte
Mid-range server with approximately 8 Gbytes of physical memory	2 Gbytes	2 Gbytes
High-end server with approximately 16 to 128 Gbytes of physical memory	4 Gbytes	4 Gbytes

In addition to the general guidelines, consider allocating swap or disk space for the following:

- A dedicated dump device.

- Determine whether large applications (like compilers) will be using the `/tmp` directory. Then allocate additional swap space to be used by TMPFS. For information about TMPFS, see “Swap Space and the TMPFS File System” on page 606.

Monitoring Swap Resources

The `/usr/sbin/swap` command is used to manage swap areas. Two options, `-l` and `-s`, display information about swap resources.

Use the `swap -l` command to identify a system’s swap areas. Activated swap devices or files are listed under the `swapfile` column.

```
# swap -l
swapfile          dev  swaplo blocks  free
/dev/dsk/c0t0d0s1 136,1    16 1638608 1600528
```

Use the `swap -s` command to monitor swap resources.

```
# swap -s
total: 57416k bytes allocated + 10480k reserved = 67896k used,
833128k available
```

The `used` value plus the `available` value equals the total swap space on the system, which includes a portion of physical memory and swap devices (or files).

You can use the amount of available and used swap space (in the `swap -s` output) as a way to monitor swap space usage over time. If a system’s performance is good, use `swap -s` to see how much swap space is available. When the performance of a system slows down, check the amount of available swap space to see if it has decreased. Then you can identify what changes to the system might have caused swap space usage to increase.

When using this command, keep in mind that the amount of physical memory available for swap usage changes dynamically as the kernel and user processes lock down and release physical memory.

Note – The `swap -l` command displays swap space in 512-byte blocks and the `swap -s` command displays swap space in 1024-byte blocks. If you add up the blocks from `swap -l` and convert them to Kbytes, the result will be less than `used + available` (in the `swap -s` output) because `swap -l` does not include physical memory in its calculation of swap space.

The output from the `swap -s` command is summarized in the following table.

TABLE 42-1 Output of the `swap -s` Command

Keyword	Description
bytes allocated	The total amount of swap space in 1024-byte blocks that is currently allocated as backing store (disk-backed swap space).
reserved	The total amount of swap space in 1024-byte blocks that is not currently allocated, but claimed by memory for possible future use.
used	The total amount of swap space in 1024-byte blocks that is either allocated or reserved.
available	The total amount of swap space in 1024-byte blocks that is currently available for future reservation and allocation.

Adding More Swap Space

As system configurations change and new software packages are installed, you might need to add more swap space. The easiest way to add more swap space is to use the `mkfile` and `swap` commands to designate a part of an existing UFS or NFS file system as a supplementary swap area. These commands, described in the following sections, enable you to add more swap space without repartitioning a disk.

Alternative ways to add more swap space are to repartition an existing disk or add another disk. For information on how to repartition a disk, see Chapter 32.

Creating a Swap File

The following general steps are involved in creating a swap file:

- Creating a swap file with the `mkfile` command
- Activating the swap file with the `swap` command
- Adding an entry for the swap file in the `/etc/vfstab` file so that the swap file is activated automatically when the system is booted.

The `mkfile` Command

The `mkfile` command creates a file that is suitable for use as either an NFS-mounted or a local swap area. The sticky bit is set, and the file is filled with zeros. You can specify the size of the swap file in bytes (the default) or in Kbytes, blocks, or Mbytes by using the `k`, `b`, or `m` suffixes, respectively.

The following table shows the `mkfile` command options.

TABLE 42-2 Options to the `mkfile` Command

Option	Description
-n	Creates an empty file. The size is noted, but the disk blocks are not allocated until data is written to them.
-v	Reports the names and sizes of created files.



Caution – Use the `-n` option only when you create an NFS swap file.

▼ How to Create a Swap File and Make It Available

1. Become superuser.

You can create a swap file without root permissions. However, to avoid accidental overwriting, root should be the owner of the swap file.

2. Create a directory for the swap file, if needed.

3. Create the swap file.

```
# mkfile nnn[k|b|m] filename
```

The swap file of the size *nnn* (in Kbytes, bytes, or Mbytes) and filename you specify is created.

4. Activate the swap file.

```
# /usr/sbin/swap -a /path/filename
```

You must use the absolute path name to specify the swap file. The swap file is added and available until the file system is unmounted, the system is rebooted, or the swap file is removed. Keep in mind that you can't unmount a file system while some process or program is swapping to the swap file.

5. Add an entry for the swap file to the `/etc/vfstab` file that specifies the full path name of the file, and designates `swap` as the file system type, as follows:

```
/path/filename - - swap - no -
```

6. Verify that the swap file is added.

```
$ /usr/sbin/swap -l
```

Example—Creating a Swap File and Making It Available

The following examples shows how to create a 100-Mbyte swap file called `/files/swapfile`.

```
# mkdir /files
# mkfile 100m /files/swapfile
# swap -a /files/swapfile
# vi /etc/vfstab
(An entry is added for the swap file) :
/files/swapfile - - swap - no -
# swap -l
swapfile          dev  swaplo blocks  free
/dev/dsk/c0t0d0s1 136,1    16 1638608 1600528
/files/swapfile   -        16 204784 204784
```

Removing a Swap File From Use

If you have unneeded swap space, you can remove it.

▼ How to Remove Unneeded Swap Space

1. **Become superuser.**

2. **Remove the swap space.**

```
# /usr/sbin/swap -d /path/filename
```

The swap file name is removed so that it is no longer available for swapping. The file itself is not deleted.

3. **Edit the `/etc/vfstab` file and delete the entry for the swap file.**

4. **Recover the disk space so that you can use it for something else.**

```
# rm /path/filename
```

If the swap space is a file, remove it. Or, if the swap space is on a separate slice and you are sure you will not need it again, make a new file system and mount the file system.

For information on mounting a file system, see Chapter 40.

5. **Verify that the swap file is no longer available.**

```
# swap -l
```

Example—Removing Unneeded Swap Space

The following examples shows how to delete the `/files/swapfile` swap file.

```
# swap -d /files/swapfile
# (Remove the swap entry from the /etc/vfstab file)
# rm /files/swapfile
# swap -l
swapfile          dev  swaplo  blocks  free
/dev/dsk/c0t0d0s1 136,1    16 1638608 1600528
```

Checking UFS File System Consistency (Tasks)

This chapter provides overview information and step-by-step instructions about checking UFS file system consistency.

This is a list of step-by-step instructions in this chapter.

- “How to See If a File System Needs Checking” on page 625
- “How to Check File Systems Interactively” on page 625
- “How to Preen a UFS File System” on page 627
- “How to Restore a Bad Superblock” on page 628

This is a list of the overview information in this chapter.

- “File System Consistency” on page 615
- “How the File System State Is Recorded” on page 616
- “What the `fsck` Command Checks and Tries to Repair” on page 618
- “Interactively Checking and Repairing a UFS File System” on page 624
- “Restoring a Bad Superblock” on page 628
- “Syntax and Options for the `fsck` Command” on page 630

For information about `fsck` error messages, see “Resolving UFS File System Inconsistencies (Tasks)” in *System Administration Guide: Advanced Administration*.

For background information on the UFS file system structures referred to in this chapter, see Chapter 44.

File System Consistency

The UFS file system relies on an internal set of tables to keep track of inodes used and available blocks. When these internal tables are not properly synchronized with data on a disk, inconsistencies result and file systems need to be repaired.

File systems can be inconsistent because of abrupt termination of the operating system in these ways:

- Power failure
- Accidental unplugging of the system
- Turning off the system without proper shutdown procedure
- A software error in the kernel

File system inconsistencies, while serious, are not common. When a system is booted, a check for file system consistency is automatically performed (with the `fsck` command). Most of the time, this file system check repairs problems it encounters.

The `fsck` command places files and directories that are allocated but unreferenced in the `lost+found` directory. A inode number is assigned as the name of unreferenced file and directory. If the `lost+found` directory does not exist, the `fsck` command creates it. If there is not enough space in the `lost+found` directory, the `fsck` command increases its size.

For a description of inodes, see “Inodes” on page 640.

How the File System State Is Recorded

The `fsck` command uses a state flag, which is stored in the superblock, to record the condition of the file system. This flag is used by the `fsck` command to determine whether a file system needs to be checked for consistency. The flag is used by the `/sbin/rcS` script during booting and by the `fsck -m` command. If you ignore the result from the `fsck -m` command, all file systems can be checked regardless of the setting of the state flag.

For a description of the superblock, see “The Superblock” on page 640.

The possible state flag values are described in the following table.

TABLE 43-1 Values of File System State Flags

State Flag Values	Description
FSACTIVE	When a file system is mounted and then modified, the state flag is set to FSACTIVE. The file system might contain inconsistencies. A file system is marked as FSACTIVE before any modified metadata is written to the disk. When a file system is unmounted gracefully, the state flag is set to FSCLEAN. A file system with the FSACTIVE flag must be checked by the <code>fsck</code> command because it might be inconsistent.

TABLE 43–1 Values of File System State Flags (Continued)

State Flag Values	Description
FSBAD	If the root (/) file system is mounted when its state is not FSCLEAN or FSSTABLE, the state flag is set to FSBAD. The kernel will not change this file system state to FSCLEAN or FSSTABLE. If a root (/) file system is flagged FSBAD as part of the boot process, it will be mounted read-only. You can run the <code>fsck</code> command on the raw root device. Then remount the root (/) file system with read and write access.
FSCLEAN	If a file system is unmounted properly, the state flag is set to FSCLEAN. Any file system with an FSCLEAN state flag is not checked when the system is booted.
FSLOG	If a file system is mounted with UFS logging, the state flag is set to FSLOG. Any file system with an FSLOG state flag is not checked when the system is booted.
FSSTABLE	The file system is (or was) mounted but has not changed since the last checkpoint (<code>sync</code> or <code>fsflush</code>) that normally occurs every 30 seconds. For example, the kernel periodically checks if a file system is idle and, if so, flushes the information in the superblock back to the disk and marks it as FSSTABLE. If the system crashes, the file system structure is stable, but users might lose a small amount of data. File systems that are marked as FSSTABLE can skip the checking before mounting. The <code>mount</code> command will not mount a file system for read and write access if the file system state is not FSCLEAN, FSSTABLE, or FSLOG.

The following table shows how the state flag is modified by the `fsck` command, based on its initial state.

TABLE 43–2 How the State Flag is Modified by `fsck`

Initial State: Before <code>fsck</code>	State After <code>fsck</code>		
	No Errors	All Errors Corrected	Uncorrected Errors
unknown	FSSTABLE	FSSTABLE	unknown
FSACTIVE	FSSTABLE	FSSTABLE	FSACTIVE
FSSTABLE	FSSTABLE	FSSTABLE	FSACTIVE
FSCLEAN	FSCLEAN	FSSTABLE	FSACTIVE
FSBAD	FSSTABLE	FSSTABLE	FSBAD
FSLOG	FSLOG	FSLOG	FSLOG

What the `fsck` Command Checks and Tries to Repair

This section describes what happens in the normal operation of a file system, what can go wrong, what problems the `fsck` command (the checking and repair utility) looks for, and how this command corrects the inconsistencies it finds.

Why Inconsistencies Might Occur

Every working day hundreds of files might be created, modified, and removed. Each time a file is modified, the operating system performs a series of file system updates. These updates, when written to the disk reliably, yield a consistent file system.

When a user program does an operation to change the file system, such as a write, the data to be written is first copied into an in-core buffer in the kernel. Normally, the disk update is handled asynchronously. The user process is allowed to proceed even though the data write might not happen until long after the write system call has returned. Thus, at any given time, the file system, as it resides on the disk, lags behind the state of the file system that is represented by the in-core information.

The disk information is updated to reflect the in-core information when the buffer is required for another use or when the kernel automatically runs the `fsflush` daemon (at 30-second intervals). If the system is halted without writing out the in-core information, the file system on the disk might be in an inconsistent state.

A file system can develop inconsistencies in several ways. The most common causes are operator error and hardware failures.

Problems might result from an *unclean shutdown*, if a system is shut down improperly, or when a mounted file system is taken offline improperly. To prevent unclean shutdowns, the current state of the file systems must be written to disk (that is, “synchronized”) before you shut down the system, physically take a disk pack out of a drive, or take a disk offline.

Inconsistencies can also result from defective hardware. Blocks can become damaged on a disk drive at any time, or a disk controller can stop functioning correctly.

The UFS Components That Are Checked for Consistency

This section describes the kinds of consistency checks that the `fsck` command applies to these UFS file system components: superblock, cylinder group blocks, inodes, indirect blocks, and data blocks.

For information about UFS file system structures, see “The Structure of Cylinder Groups for UFS File Systems” on page 639.

Superblock Checks

The superblock stores summary information, which is the most commonly corrupted component in a UFS file system. Each change to the file system inodes or data blocks also modifies the superblock. If the CPU is halted and the last command is not a `sync` command, the superblock almost certainly becomes corrupted.

The superblock is checked for inconsistencies in the following:

- File system size
- Number of inodes
- Free block count
- Free inode count

File System Size and Inode List Size Checks

The file system size must be larger than the number of blocks used by the superblock and the list of inodes. The number of inodes must be less than the maximum number allowed for the file system. An inode represents all the information about a file. The file system size and layout information are the most critical pieces of information for the `fsck` command. Although there is no way to actually check these sizes because they are statically determined when the file system is created. However, the `fsck` command can check that the sizes are within reasonable bounds. All other file system checks require that these sizes be correct. If the `fsck` command detects corruption in the static parameters of the primary superblock, it requests the operator to specify the location of an alternate superblock.

For more information about the structure of the UFS file system, see “The Structure of Cylinder Groups for UFS File Systems” on page 639.

Free Block Checks

Free blocks are stored in the cylinder group block maps. The `fsck` command checks that all the blocks marked as free are not claimed by any files. When all the blocks have been accounted for, the `fsck` command checks to see if the number of free blocks plus the number of blocks that are claimed by the inodes equal the total number of blocks in the file system. If anything is wrong with the block maps, the `fsck` command rebuilds them, leaving out blocks already allocated.

The summary information in the superblock includes a count of the total number of free blocks within the file system. The `fsck` command compares this count to the number of free blocks it finds within the file system. If the counts do not agree, the `fsck` command replaces the count in the superblock with the actual free-block count.

Free Inode Checks

The summary information in the superblock contains a count of the free inodes within the file system. The `fsck` command compares this count to the number of free inodes it finds within the file system. If the counts do not agree, `fsck` replaces the count in the superblock with the actual free inode count.

Inodes

The list of inodes is checked sequentially starting with inode 2 (inode 0 and inode 1 are reserved). Each inode is checked for inconsistencies in the following:

- Format and type
- Link count
- Duplicate block
- Bad block numbers
- Inode size

Format and Type of Inodes

Each inode contains a mode word, which describes the type and state of the inode. Inodes might be one of nine types:

- Regular
- Directory
- Block special
- Character special
- FIFO (named-pipe)
- Symbolic link
- Shadow (used for ACLs)
- Attribute directory
- Socket

Inodes might be in one of three states:

- Allocated
- Unallocated
- Partially allocated

When the file system is created, a fixed number of inodes are set aside, but they are not allocated until they are needed. An allocated inode is one that points to a file. An unallocated inode does not point to a file and, therefore, should be empty. The partially allocated state means that the inode is incorrectly formatted. An inode can get into this state if, for example, bad data is written into the inode list because of a hardware failure. The only corrective action the `fsck` command can take is to clear the inode.

Link Count Checks

Each inode contains a count of the number of directory entries linked to it. The `fsck` command verifies the link count of each inode by examining the entire directory structure, starting from the root directory, and calculating an actual link count for each inode.

Discrepancies between the link count stored in the inode and the actual link count as determined by the `fsck` command might be of three types:

- The stored count is *not* 0 and the actual count is 0.
This condition can occur if no directory entry exists for the inode. In this case, the `fsck` command puts the disconnected file in the `lost+found` directory.
- The stored count is *not* 0 and the actual count is *not* 0, but the counts are *unequal*.
This condition can occur if a directory entry has been added or removed, but the inode has not been updated. In this case, the `fsck` command replaces the stored link count with the actual link count.
- The stored count is 0 and the actual count is not 0.
In this case, the `fsck` command changes the link count of the inode to the actual count.

Duplicate Block Checks

Each inode contains a list, or pointers to lists (indirect blocks), of all the blocks claimed by the inode. Because indirect blocks are owned by an inode, inconsistencies in indirect blocks directly affect the inode that owns the indirect block.

The `fsck` command compares each block number claimed by an inode to a list of allocated blocks. If another inode already claims a block number, the block number is put on a list of duplicate blocks. Otherwise, the list of allocated blocks is updated to include the block number.

If there are any duplicate blocks, the `fsck` command makes a second pass of the inode list to find the other inode that claims each duplicate block. (A large number of duplicate blocks in an inode might be caused by an indirect block not being written to the file system.) It is not possible to determine with certainty which inode is in error. The `fsck` command prompts you to choose which inode should be kept and which should be cleared.

Bad Block Number Checks

The `fsck` command checks each block number claimed by an inode to see that its value is higher than that of the first data block and lower than that of the last data block in the file system. If the block number is outside this range, it is considered a bad block number.

Bad block numbers in an inode might be caused by an indirect block not being written to the file system. The `fsck` command prompts you to clear the inode.

Inode Size Checks

Each inode contains a count of the number of data blocks that it references. The number of actual data blocks is the sum of the allocated data blocks and the indirect blocks. The `fsck` command computes the number of data blocks and compares that block count against the number of blocks that the inode claims. If an inode contains an incorrect count, the `fsck` command prompts you to fix it.

Each inode contains a 64-bit size field. This field shows the number of characters (data bytes) in the file associated with the inode. A rough check of the consistency of the size field of an inode is done by using the number of characters shown in the size field to calculate how many blocks should be associated with the inode, and then comparing that to the actual number of blocks claimed by the inode.

Indirect Blocks

Indirect blocks are owned by an inode. Therefore, inconsistencies in an indirect block affect the inode that owns it. Inconsistencies that can be checked are the following:

- Blocks already claimed by another inode
- Block numbers outside the range of the file system

These consistency checks listed are also performed for indirect blocks.

Data Blocks

An inode can directly or indirectly reference three kinds of data blocks. All referenced blocks must be of the same kind. The three types of data blocks are the following:

- Plain data blocks
- Symbolic-link data blocks
- Directory data blocks

Plain data blocks contain the information stored in a file. Symbolic-link data blocks contain the path name stored in a symbolic link. Directory data blocks contain directory entries. The `fsck` command can check only the validity of directory data blocks.

Directories are distinguished from regular files by an entry in the mode field of the inode. Data blocks associated with a directory contain the directory entries. Directory data blocks are checked for inconsistencies involving the following:

- Directory inode numbers that point to unallocated inodes
- Directory inode numbers that are greater than the number of inodes in the file system

- Incorrect directory inode numbers for “.” and “..” directories
- Directories that are disconnected from the file system

Directory Unallocated Checks

If the inode number in a directory data block points to an unallocated inode, the `fsck` command removes the directory entry. This condition can occur if the data blocks that contain a new directory entry are modified and written out, but the inode does not get written out. This condition can occur if the CPU is shutdown abruptly.

Bad Inode Number Checks

If a directory entry inode number points beyond the end of the inode list, the `fsck` command removes the directory entry. This condition can occur when bad data is written into a directory data block.

Incorrect “.” and “..” Entry Checks

The directory inode number entry for “.” must be the first entry in the directory data block. The directory inode number must reference itself; that is, its value must be equal to the inode number for the directory data block.

The directory inode number entry for “..” must be the second entry in the directory data block. The directory inode number value must be equal to the inode number of the parent directory (or the inode number of itself if the directory is the root directory).

If the directory inode numbers for “.” and “..” are incorrect, the `fsck` command replaces them with the correct values. If there are multiple hard links to a directory, the first hard link found is considered the real parent to which “..” should point. In this case, the `fsck` command recommends that you have it delete the other names.

Disconnected Directories

The `fsck` command checks the general connectivity of the file system. If a directory is found that is not linked to the file system, the `fsck` command links the directory to the `lost+found` directory of the file system. This condition can occur when inodes are written to the file system, but the corresponding directory data blocks are not.

Regular Data Blocks

Data blocks associated with a regular file hold the contents of the file. The `fsck` command does not attempt to check the validity of the contents of a regular file’s data blocks.

The fsck Summary Message

When you run the `fsck` command interactively and it completes successfully, a message similar to the following is displayed:

```
# fsck /dev/rdisk/c0t0d0s7
** /dev/rdisk/c0t0d0s7
** Last Mounted on /export/home
** Phase 1 - Check Blocks and Sizes
** Phase 2 - Check Pathnames
** Phase 3 - Check Connectivity
** Phase 4 - Check Reference Counts
** Phase 5 - Check Cyl groups
2 files, 9 used, 2833540 free (20 frags, 354190 blocks, 0.0% fragmentation)
#
```

The last line of `fsck` output describes the following information about the file system:

# files	Number of inodes in use
# used	Number of fragments in use
# free	Number of unused fragments
# frags	Number of unused non-block fragments
# blocks	Number of unused full blocks
% fragmentation	Percentage of fragmentation, where: free fragments x 100 / total fragments in the file system

For information about fragments, see “Fragment Size” on page 644.

Interactively Checking and Repairing a UFS File System

You might need to interactively check file systems in the following instances:

- When they cannot be mounted
- When they develop inconsistencies while in use

When an in-use file system develops inconsistencies, error messages might be displayed in the console window or the system might crash.

Before using the `fsck` command, you might want to refer to “Syntax and Options for the `fsck` Command” on page 630 and “Resolving UFS File System Inconsistencies (Tasks)” in *System Administration Guide: Advanced Administration* for more information.

▼ How to See If a File System Needs Checking

1. Become superuser or assume an equivalent role.
2. Unmount the file system if it is mounted.

```
# umount /mount-point
```

3. Check the file system.

```
# fsck -m /dev/rdisk/device-name
```

The state flag in the superblock of the file system you specify is checked to see whether the file system is clean or requires checking.

If you omit the device argument, all the UFS file systems listed in the `/etc/vfstab` file with a `fsck pass` value greater than 0 are checked.

Example—Seeing If a File System Needs Checking

The following example shows that the file system needs checking.

```
# fsck -m /dev/rdisk/c0t0d0s6
** /dev/rdisk/c0t0d0s6
ufs fsck: sanity check: /dev/rdisk/c0t0d0s6 needs checking
```

▼ How to Check File Systems Interactively

1. Become superuser or assume an equivalent role.
2. Unmount the local file systems except root (/) and /usr.

```
# umountall -l
```

3. Check the file systems.

```
# fsck
```

All file systems in the `/etc/vfstab` file with entries in the `fsck pass` field greater than 0 are checked. You can also specify the mount point directory or `/dev/rdisk/device-name` as arguments to the `fsck` command. Any inconsistency messages are displayed.

For information about how to respond to the error message prompts while interactively checking one or more UFS file systems, see “Resolving UFS File System Inconsistencies (Tasks)” in *System Administration Guide: Advanced Administration*.



Caution – Running the `fsck` command on a mounted file system might cause a system to crash if the `fsck` command makes any changes, unless stated otherwise, such as running the `fsck` command in single-user mode to repair a file system.

4. If you corrected any errors, type `fsck` and press Return.

The `fsck` command might be unable to fix all errors in one execution. If you see the message `FILE SYSTEM STATE NOT SET TO OKAY`, run the command again. If that does not work, see “Fixing a UFS File System That the `fsck` Command Cannot Repair” on page 627.

5. Rename and move any files put in the `lost+found` directory.

Individual files put in the `lost+found` directory by the `fsck` command are renamed with their inode numbers. If possible, rename the files and move them where they belong. You might be able to use the `grep` command to match phrases with individual files and the `file` command to identify file types. When whole directories are put into the `lost+found` directory, it is easier to figure out where they belong and to move them back.

Example—Checking File Systems Interactively

The following example shows how to check the `/dev/rdisk/c0t0d0s6` file system and corrects the incorrect block count.

```
# fsck /dev/rdisk/c0t0d0s6
checkfilesystems: /dev/rdisk/c0t0d0s6
** Phase 1 - Check Block and Sizes
INCORRECT BLOCK COUNT I=2529 (6 should be 2)
CORRECT? y

** Phase 2 - Check Pathnames
** Phase 3 - Check Connectivity
** Phase 4 - Check Reference Counts
** Phase 5 - Cylinder Groups
929 files, 8928 used, 2851 free (75 frags, 347 blocks, 0.6%
fragmentation)
/dev/rdisk/c0t0d0s6 FILE SYSTEM STATE SET TO OKAY

***** FILE SYSTEM WAS MODIFIED *****
```

Preening UFS File Systems

The `fsck -o p` command (`p` is for preen) checks UFS file systems and automatically fixes the problems that normally result from an unexpected system shutdown. This command exits immediately if it encounters a problem that requires operator intervention. This command also permits parallel checking of file systems.

You can run the `fsck -o p` command to preen the file systems after an unclean shutdown. In this mode, the `fsck` command does not look at the clean flag and does a full check. These actions are a subset of the actions that the `fsck` command takes when it runs interactively.

▼ How to Preen a UFS File System

1. **Become superuser or assume an equivalent role.**
2. **Unmount the UFS file system.**

```
# umount /mount-point
```

3. **Check the UFS file system with the preen option.**

```
# fsck -o p /dev/rdisk/device-name
```

You can preen individual file systems by using `/mount-point` or `/dev/rdisk/device-name` as arguments to the `fsck` command.

Example—Preening a UFS File System

The following example shows how to preen the `/usr` file system.

```
# fsck -o p /usr
```

Fixing a UFS File System That the `fsck` Command Cannot Repair

Sometimes, you need to run the `fsck` command a few times to fix a file system because problems corrected on one pass might uncover other problems not found in earlier passes. The `fsck` command does not keep running until it comes up clean, so you must rerun it manually.

Pay attention to the information displayed by the `fsck` command. This information might help you fix the problem. For example, the messages might point to a damaged directory. If you delete the directory, you might find that the `fsck` command runs cleanly.

If the `fsck` command still cannot repair the file system, you can try to use the `fsdb`, `ff`, `clri`, and `ncheck` commands to figure out and fix what is wrong. For information about how to use these commands, see `fsdb(1M)`, `ff(1M)`, `clri(1M)`, and `ncheck(1M)`. You might, ultimately, need to re-create the file system and restore its contents from backup media.

For information about restoring complete file systems, see Chapter 49.

If you cannot fully repair a file system but you can mount it read-only, try using the `cp`, `tar`, or `cpio` commands to retrieve all or part of the data from the file system.

If hardware disk errors are causing the problem, you might need to reformat and divide the disk into slices again before re-creating and restoring file systems. Hardware errors usually display the same error again and again across different commands. The `format` command tries to work around bad blocks on the disk. If the disk is too severely damaged, however, the problems might persist, even after reformatting. For information about using the `format` command, see `format(1M)`. For information about installing a new disk, see Chapter 34 or Chapter 35.

Restoring a Bad Superblock

When the superblock of a file system becomes damaged, you must restore it. The `fsck` command tells you when a superblock is bad. Fortunately, copies of the superblock are stored within a file system. You can use the `fsck -ob` command to replace the superblock with one of the copies.

For more information about the superblock, see “The Superblock” on page 640.

If the superblock in the root (`/`) file system becomes damaged and you cannot restore it, you have two choices:

- Reinstall the system
- Boot from the network or local CD, and attempt the following steps. If these steps fail, recreate the root (`/`) file system with the `newfs` command and restore it from a backup copy.

▼ How to Restore a Bad Superblock

1. **Become superuser or assume an equivalent role.**
2. **Determine whether the bad superblock is in the root (`/`) or `/usr` file system and select one of the following:**
 - a. **Stop the system and boot from the network or a locally-connected CD if the bad superblock is in the root (`/`) or `/usr` file system.**

From a locally-connected CD, use the following command:

```
ok boot cdrom -s
```

From the network where a boot or install server is already setup, use the following command:

```
ok boot net -s
```

If you need help stopping the system, see “SPARC: How to Stop the System for Recovery Purposes” on page 190 or “x86: How to Stop a System for Recovery Purposes” on page 204.

- b. Change to a directory outside the damaged file system and unmount the file system if the bad superblock is not in the root (/) or /usr file system.

```
# umount /mount-point
```



Caution – Be sure to use the `newfs -N` in the next step. If you omit the `-N` option, you will create a new, empty file system.

3. Display the superblock values with the `newfs -N` command.

```
# newfs -N /dev/rdisk/device-name
```

The output of this command displays the block numbers that were used for the superblock copies when the `newfs` command created the file system, unless the file system was created with special parameters. For information on creating a customized file system, see “Custom File System Parameters” on page 643.

4. Provide an alternate superblock with the `fsck` command.

```
# fsck -F ufs -o b=block-number /dev/rdisk/device-name
```

The `fsck` command uses the alternate superblock you specify to restore the primary superblock. You can always try 32 as an alternate block, or use any of the alternate blocks shown by the `newfs -N` command.

Example—Restoring a Bad Superblock

The following example shows how to restore the superblock copy 5264.

```
# newfs -N /dev/rdisk/c0t3d0s7
/dev/rdisk/c0t3d0s7: 163944 sectors in 506 cylinders of 9 tracks, 36 sectors
 83.9MB in 32 cyl groups (16 c/g, 2.65MB/g, 1216 i/g)
super-block backups (for fsck -b #) at:
 32, 5264, 10496, 15728, 20960, 26192, 31424, 36656, 41888,
 47120, 52352, 57584, 62816, 68048, 73280, 78512, 82976, 88208,
 93440, 98672, 103904, 109136, 114368, 119600, 124832, 130064, 135296,
 140528, 145760, 150992, 156224, 161456,
# fsck -F ufs -o b=5264 /dev/rdisk/c0t3d0s7
Alternate superblock location: 5264.
** /dev/rdisk/c0t3d0s7
** Last Mounted on
** Phase 1 - Check Blocks and Sizes
** Phase 2 - Check Pathnames
** Phase 3 - Check Connectivity
** Phase 4 - Check Reference Counts
** Phase 5 - Check Cyl groups
```

```
36 files, 867 used, 75712 free (16 frags, 9462 blocks, 0.0% fragmentation)
/dev/rdsk/c0t3d0s7 FILE SYSTEM STATE SET TO OKAY
```

```
***** FILE SYSTEM WAS MODIFIED *****
#
```

Syntax and Options for the `fsck` Command

The `fsck` command checks and repairs inconsistencies in file systems. If you run the `fsck` command without any options, it interactively asks for confirmation before making repairs. This command has four options:

Command and Option	Description
<code>fsck -m</code>	Checks whether a file system can be mounted
<code>fsck -y</code>	Assumes a yes response for all repairs
<code>fsck -n</code>	Assumes a no response for all repairs
<code>fsck -o p</code>	Noninteractively preens the file system, fixing all expected (innocuous) inconsistencies, but exits when a serious problem is encountered

UFS File System (Reference)

This is a list of the reference information in this chapter.

- “Default Directories for root (/) and /usr File Systems” on page 631
- “The Platform-Dependent Directories” on page 639
- “The Structure of Cylinder Groups for UFS File Systems” on page 639
- “Custom File System Parameters” on page 643
- “Commands for Creating a Customized File System” on page 646

Default Directories for root (/) and /usr File Systems

The `/kernel` directory contains only platform-independent objects, including a platform-independent kernel, `genunix`. For a description of `/platform` and `/usr/platform`, the platform-dependent directories, see Table 44–3.

The following table describes the directories that are contained in the root (/) file system.

TABLE 44–1 Default Directories in the root (/) File System

Directory	Description
/	Root of the overall file system name space
/dev	Primary location for logical device files
/dev/cfg	Symbolic links to physical <code>ap_ids</code>
/dev/cua	Device files for <code>uucp</code>

TABLE 44-1 Default Directories in the root (/) File System (Continued)

Directory	Description
/dev/dsk	Block disk devices
/dev/fbs	Frame buffer device files
/dev/fd	File descriptors
/dev/md	Volume management device names
/dev/printers	USB printer device files
/dev/pts	pty slave devices
/dev/rdisk	Raw disk devices
/dev/rmt	Raw tape devices
/dev/sad	Entry points for the STREAMS Administrative Driver
/dev/sound	Audio device and audio device control files
/dev/swap	Default swap device
/dev/term	Serial devices
/devices	Physical device files
/etc	Host-specific system administration configuration files and databases
/etc/acct	Accounting configuration information
/etc/apache	Apache configuration files
/etc/cron.d	Configuration information for cron
/etc/default	Defaults information for various programs
/etc/dfs	Configuration information for shared file systems
/etc/dhcp	Dynamic Host Configuration Protocol (DHCP) configuration files
/etc/dmi	Solstice Enterprise Agents configuration files
/etc/fn	Federated Naming Service and x.500 support files
/etc/fs	Binaries organized by file system types
/etc/ftpd	ftpd configuration files
/etc/gss	Generic Security Service (GSS) Application Program Interface configuration files
/etc/gtk	GNOME (GNU Network Object Model Environment) configuration files

TABLE 44-1 Default Directories in the root (/) File System (Continued)

Directory	Description
/etc/inet	Configuration files for Internet services
/etc/init.d	Scripts for changing run levels
/etc/iplanet	iPlanet configuration files
/etc/krb5	Kerberos configuration files
/etc/lib	Dynamic linking libraries that are needed when /usr is not available
/etc/l1c2	Logical link control (l1c2) driver configuration files
/etc/lp	Configuration information for the printer subsystem
/etc/lu	Solaris Live Upgrade configuration files
/etc/lvm	Solaris Volume Manager configuration files
/etc/mail	Mail subsystem configuration information
/etc/nca	Solaris Network Cache and Accelerator (NCA) configuration files
/etc/net	Configuration information for TI (transport- independent) network services
/etc/nfs	NFS server logging configuration file
/etc/openwin	OpenWindows configuration files
/etc/opt	Configuration information for optional packages
/etc/ppp	Solaris PPP configuration files
/etc/rc0.d	Scripts for entering or leaving run level 0
/etc/rc1.d	Scripts for entering or leaving run level 1
/etc/rc2.d	Scripts for entering or leaving run level 2
/etc/rc3.d	Scripts for entering or leaving run level 3
/etc/rcS.d	Scripts for bringing the system to single-user mode
/etc/rcm	Directory for reconfiguration manager (RCM) custom scripts
/etc/rpcsec	Might contain an NIS+ authentication configuration file
/etc/saf	Service access facility files (including FIFOs)
/etc/security	Basic Security Module (BSM) configuration files
/etc/sfw	Samba configuration files
/etc/skel	Default profile scripts for new user accounts

TABLE 44-1 Default Directories in the root (/) File System (Continued)

Directory	Description
/etc/smartcard	Solaris SmartCards configuration files
/etc/snmp	Solstice Enterprise Agents configuration files
/etc/ssh	Secure shell configuration files
/etc/sysevent	syseventd configuration files
/etc/tm	Trademark files, whose contents are displayed at boot time
/etc/usb	USB configuration information
/etc/uucp	uucp configuration information
/etc/wrsm	WCI Remote Shared Memory (WRSM) configuration information
/export	Default directory for users' home directories, client file systems, or other shared file systems
/home	Default directory or mount point for a user's home directory on a standalone system. When AutoFS is running, you cannot create any new entries in this directory.
/kernel	Directory of platform-independent loadable kernel modules that are required as part of the boot process. Includes the generic part of the core kernel that is platform-independent, /kernel/genunix. See Table 44-3 for the /platform and /usr/platform directory structure.
/mnt	Convenient, temporary mount point for file systems
/opt	Default directory or mount point for add-on application packages
/platform	Supported platform files. For more information, see Table 44-3.
/proc	Process information
/sbin	Essential executables used in the booting process and in manual system failure recovery
/tmp	Temporary files, whose contents are cleared during boot sequence
/usr	Mount point for the /usr file system. For more information, see Table 44-2.
/var	Directory for varying files, which usually includes temporary files, logging files, or status files
/var/adm	System logging files and accounting files

TABLE 44-1 Default Directories in the root (/) File System (Continued)

Directory	Description
/var/apache	Scripts, icons, logs, and cache pages for Apache web server
/var/audit	Basic Security Module (BSM) audit files
/var/crash	Default depository for kernel crash dumps
/var/cron	cron's log file
/var/dmi	Solstice Enterprise Agents Desktop Management Interface (DMI) run-time components
/var/dt	dtlogin configuration files
/var/inet	IPv6 router state files
/var/krb5	Database and log files for Kerberos
/var/ld	Configuration files for run-time linker
/var/ldap	LDAP client configuration files
/var/log	System log files
/var/lp	Line printer subsystem logging information
/var/mail	Directory where user mail is kept
/var/news	Community service messages. These messages are not the same as USENET-style news.
/var/nfs	NFS server log files
/var/nis	NIS+ databases
/var/ntp	Network Time Protocol (NTP) server state directory
/var/opt	Root of a subtree for varying files that are associated with software packages
/var/preserve	Backup files for vi and ex
/var/run	Temporary system files that are not needed across system reboots. A TMPFS-mounted directory.
/var/sadm	Databases that are maintained by the software package management utilities
/var/saf	saf (service access facility) logging files and accounting files
/var/samba	Log files and lock files for Samba
/var/snmp	SNMP status and configuration information
/var/spool	Directories for spooled temporary files

TABLE 44-1 Default Directories in the root (/) File System (Continued)

Directory	Description
/var/spool/clientmqueue	Sendmail client files
/var/spool/cron	cron and at spool files
/var/spool/locks	Spooling lock files
/var/spool/lp	Line printer spool files
/var/spool/mqueue	Mail queued for delivery
/var/spool/pkg	Spoiled packages
/var/spool/print	LP print service client-side request staging area
/var/spool/samba	Samba print queue
/var/spool/uucp	Queued uucp jobs
/var/spool/uucppublic	Files deposited by uucp
/var/statmon	Network status monitor files
/var/tmp	Directory for temporary files that are not cleared during boot sequence
/var/uucp	uucp log files and status files
/var/yp	NIS databases

The following table describes the default directories in the /usr file system.

TABLE 44-2 Default Directories in the /usr File System

Directory	Description
4lib	SunOS 4.1 binary compatibility package libraries
5bin	Symbolic link to the /usr/bin directory
X	Symbolic link to the /usr/openwin directory
adm	Symbolic link to the /var/adm directory
apache	Apache executables, loadable modules, and documentation
aset	Directory for Automated Security Enhancement Tools (ASET) programs and files
bin	Location for standard system commands
ccs	C compilation programs and libraries
demo	Demo programs and data

TABLE 44-2 Default Directories in the /usr File System (Continued)

Directory	Description
dict	Symbolic link to the /usr/share/lib/dict directory, which contains the dictionary file used by the UNIX spell program
dt	Directory or mount point for CDE software
games	An empty directory, which is a remnant of the SunOS 4.0-4.1 software
include	Header files for C programs, and so on.
iplanet	Directory server executables, loadable modules, and documentation
j2se	Java 2 SDK executables, loadable modules, and documentation
java*	Directories that contain Java programs and libraries
kernel	Additional kernel modules
kvm	Obsolete
lib	Various program libraries, architecture-dependent databases, and binaries not invoked directly by the user
local	Commands local to a site
mail	Symbolic link to the /var/mail directory
man	Symbolic link to the /usr/share/man directory
net	Directory for network listener services
news	Symbolic link to the /var/news directory
oasys	Files for the Form and Menu Language Interpreter (FMLI) execution environment
old	Programs that are being phased out
openwin	Directory or mount point for OpenWindows software
perl5	Perl 5 programs and documentation
platform	Supported platform files. For more information, see Table 44-3.
preserve	Symbolic link to the /var/preserve directory
proc	Directory for the proc tools
pub	Files for online man page and character processing

TABLE 44-2 Default Directories in the /usr File System (Continued)

Directory	Description
sadm	Various files and directories related to system administration
sbin	Executables for system administration
sbin/install.d	Custom JumpStart scripts and executables
sbin/static	Statically linked version of selected programs from /usr/bin and /usr/sbin
sbin/sparc7 and sparc9	32-bit and 64-bit versions of commands
sfw	GNU and open source executables, libraries, and documentation
share	Architecture-independent sharable files
share/admserv5.1	iPlanet Console and Administration Server 5.0 documentation
share/audio	Sample audio files
share/ds5	iPlanet Directory Server 5.1 Documentation
share/lib	Architecture-independent databases
share/man	Solaris manual pages
share/src	Source code for kernel, libraries, and utilities
snadm	Programs and libraries related to system and network administration
spool	Symbolic link to the /var/spool directory
src	Symbolic link to the share/src directory
tmp	Symbolic link to the var/tmp directory
ucb	Berkeley compatibility package binaries
ucbinclude	Berkeley compatibility package header files
ucblib	Berkeley compatibility package libraries
vmsys	Directory for Framed Access Command Environment (FACE) programs
xpg4	Directory for POSIX-compliant utilities

The Platform-Dependent Directories

The following table describes the platform-dependent objects in the `/platform` and `/usr/platform` directories.

TABLE 44-3 The `/platform` and `/usr/platform` Directories

Directory	Description
<code>/platform</code>	Contains a series of directories, one directory per supported platform that needs to reside in the root (<code>/</code>) file system.
<code>/platform/*/kernel</code>	Contains platform-dependent kernel components, including the file <code>unix</code> , the core kernel that is platform-dependent. For more information, see <code>kernel(1M)</code> .
<code>/usr/platform</code>	Contains platform-dependent objects that do not need to reside in the root (<code>/</code>) file system.
<code>/usr/platform/*/lib</code>	Contains platform-dependent objects similar to those objects found in the <code>/usr/lib</code> directory.
<code>/usr/platform/*/sbin</code>	Contains platform-dependent objects similar to those objects found in the <code>/usr/sbin</code> directory.

The Structure of Cylinder Groups for UFS File Systems

When you create a UFS file system, the disk slice is divided into *cylinder groups*, which is made up of one or more consecutive disk cylinders. The cylinder groups are then further divided into addressable blocks to control and organize the structure of the files within the cylinder group. Each type of block has a specific function in the file system. A UFS file system has these four types of blocks:

Block Type	Type of Information Stored
Boot block	Information used when booting the system
Superblock	Detailed information about the file system
Inode	All information about a file

Block Type	Type of Information Stored
Storage or data block	Data for each file

The following sections provide additional information about the organization and function of these blocks.

The Boot Block

The boot block stores objects that are used in booting the system. If a file system is not to be used for booting, the boot block is left blank. The boot block appears only in the first cylinder group (cylinder group 0) and is the first 8 Kbytes in a slice.

The Superblock

The superblock stores much of the information about the file system, which includes the following:

- Size and status of the file system
- Label, which includes file system name and volume name
- Size of the file system logical block
- Date and time of the last update
- Cylinder group size
- Number of data blocks in a cylinder group
- Summary data block
- File system state
- Path name of the last mount point

Because the superblock contains critical data, multiple superblocks are made when the file system is created.

A summary information block is kept within the superblock. The summary information block is not replicated, but is grouped with the primary superblock, usually in cylinder group 0. The summary block records changes that take place as the file system is used. In addition, the summary block lists the number of inodes, directories, fragments, and storage blocks within the file system.

Inodes

An inode contains all the information about a file except its name, which is kept in a directory. An inode is 128 bytes. The inode information is kept in the cylinder information block, and contains the following:

- The type of the file:

- Regular
- Directory
- Block special
- Character special
- FIFO, also known as named pipe
- Symbolic link
- Socket
- Other inodes – attribute directory and shadow (used for ACLs)
- The mode of the file (the set of read-write-execute permissions)
- The number of hard links to the file
- The user ID of the owner of the file
- The group ID to which the file belongs
- The number of bytes in the file
- An array of 15 disk-block addresses
- The date and time the file was last accessed
- The date and time the file was last modified
- The date and time the file was created

The array of 15 disk addresses (0 to 14) points to the data blocks that store the contents of the file. The first 12 are direct addresses. That is, they point directly to the first 12 logical storage blocks of the file contents. If the file is larger than 12 logical blocks, the 13th address points to an indirect block, which contains direct block addresses instead of file contents. The 14th address points to a double indirect block, which contains addresses of indirect blocks. The 15th address is for triple indirect addresses. The following figure shows this chaining of address blocks starting from the inode.

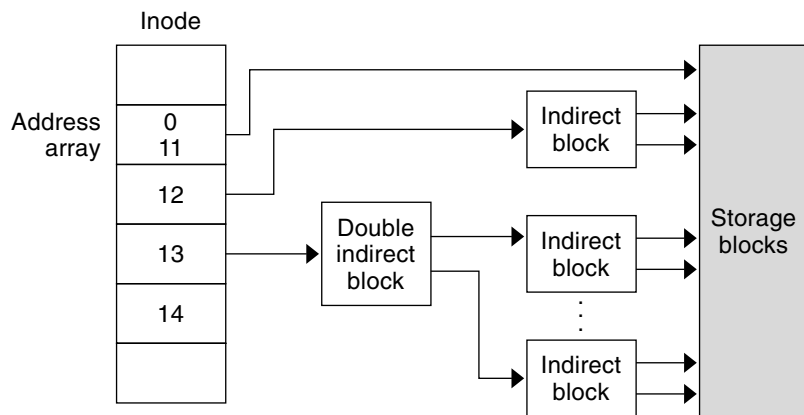

FIGURE 44-1 Address Chain for a UFS File System

Data Blocks

Data blocks, also called storage blocks, contain the rest of the space that is allocated to the file system. The size of these data blocks is determined at the time a file system is created. Data blocks are allocated, by default, in two sizes: an 8-Kbyte logical block size, and a 1-Kbyte fragment size.

For a regular file, the data blocks contain the contents of the file. For a directory, the data blocks contain entries that give the inode number and the file name of the files in the directory.

Free Blocks

Blocks that are not currently being used as inodes, as indirect address blocks, or as storage blocks are marked as free in the cylinder group map. This map also keeps track of fragments to prevent fragmentation from degrading disk performance.

To give you an idea of the appearance of a typical UFS file system, the following figure shows a series of cylinder groups in a generic UFS file system.

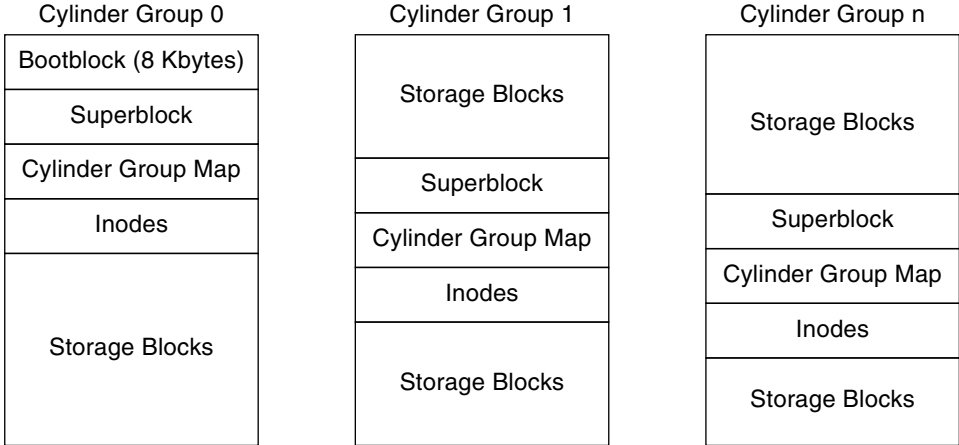

FIGURE 44-2 A Typical UFS File System

Custom File System Parameters

Before you choose to alter the default file system parameters that are assigned by the `newfs` command, you need to understand them. This section describes each of these parameters:

- Logical block size
- Fragment size
- Minimum free space
- Rotational delay
- Optimization type
- Number of files

Logical Block Size

The logical block size is the size of the blocks that the UNIX kernel uses to read or write files. The logical block size is usually different from the physical block size. The physical block size is usually 512 bytes, which is the size of the smallest block that the disk controller can read or write.

Logical block size is set to the page size of the system by default. The default logical block size is 8192 bytes (8 Kbytes) for UFS file systems. The UFS file system supports block sizes of 4096 or 8192 bytes (4 or 8 Kbytes). The recommended logical block size is 8 Kbytes.

SPARC only – You can specify only the 8192-byte block size on the sun4u platform.

To choose the best logical block size for your system, consider both the performance desired and the available space. For most UFS systems, an 8-Kbyte file system provides the best performance, offering a good balance between disk performance and the use of space in primary memory and on disk.

As a general rule, to increase efficiency, use a larger logical block size for file systems where most of the files are very large. Use a smaller logical block size for file systems where most of the files are very small. You can use the `quot -c file-system` command on a file system to display a complete report on the distribution of files by block size.

However, the page size set when the file system is created is probably best in most cases.

Fragment Size

As files are created or expanded, they are allocated disk space in either full logical blocks or portions of logical blocks called *fragments*. When disk space is needed for a file, full blocks are allocated first, and then one or more fragments of a block are allocated for the remainder. For small files, allocation begins with fragments.

The ability to allocate fragments of blocks to files, rather than just whole blocks, saves space by reducing *fragmentation* of disk space that results from unused holes in blocks.

You define the *fragment size* when you create a UFS file system. The default fragment size is 1 Kbyte. Each block can be divided into 1, 2, 4, or 8 fragments, which results in fragment sizes from 8192 bytes to 512 bytes (for 4-Kbyte file systems only). The lower bound is actually tied to the disk sector size, typically 512 bytes.

For multiterabyte file systems, the fragment size must be equal to the file system block size.

Note – The upper bound for the fragment is the logical block size, in which case the fragment is not a fragment at all. This configuration might be optimal for file systems with very large files when you are more concerned with speed than with space.

When choosing a fragment size, look at the trade-off between time and space: a small fragment size saves space, but requires more time to allocate. As a general rule, to increase storage efficiency, use a larger fragment size for file systems where most of the files are large. Use a smaller fragment size for file systems where most of the files are small.

Minimum Free Space

The *minimum free space* is the percentage of the total disk space that is held in reserve when you create the file system. The default reserve is $((64 \text{ Mbytes}/\text{partition size}) * 100)$, rounded down to the nearest integer and limited between 1 percent and 10 percent, inclusively.

Free space is important because file access becomes less and less efficient as a file system gets full. As long as an adequate amount of free space exists, UFS file systems operate efficiently. When a file system becomes full, using up the available user space, only root can access the reserved free space.

Commands such as `df` report the percentage of space that is available to users, excluding the percentage allocated as the minimum free space. When the command reports that more than 100 percent of the disk space in the file system is in use, some of the reserve has been used by root.

If you impose quotas on users, the amount of space available to the users does not include the reserved free space. You can change the value of the minimum free space for an existing file system by using the `tune2fs` command.

Rotational Delay

This parameter is obsolete for modern disks. If you need to use this parameter, the default value provided when the file system is created is probably best for most cases.

Optimization Type

The *optimization type* parameter is set to either *space* or *time*.

- **Space** – When you select space optimization, disk blocks are allocated to minimize fragmentation and disk use is optimized.
- **Time** – When you select time optimization, disk blocks are allocated as quickly as possible, with less emphasis on their placement. When there is enough free space, it is relatively easy to allocate disk blocks effectively, without resulting in too much fragmentation. The default is *time*.

You can change the value of the optimization type parameter for an existing file system by using the `tune2fs` command.

For more information, see `tune2fs(1M)`.

Number of Inodes (Files)

The number of inodes parameter determines the number of files you can have in the file system: one inode for each file. The *number of bytes per inode* determines the total number of inodes that are created when the file system is made: the total size of the file system divided by the number of bytes per inode. Once the inodes are allocated, you cannot change the number without re-creating the file system.

The default number of bytes per inode is 2048 bytes (2 Kbytes) if the file system is less than one Gbyte. If the file system is larger than one Gbyte, the following formula is used:

File System Size	Number of Bytes Per Inode
Less than or equal to 1 Gbyte	2048
Less than 2 Gbytes	4096

File System Size	Number of Bytes Per Inode
Less than 3 Gbytes	6144
3 Gbytes up to 1 Tbyte	8192
Greater than 1 Tbyte	1048576

If you have a file system with many symbolic links, they can lower the average file size. If your file system is going to have many small files, you can give this parameter a lower value. Note, however, that having too many inodes is much better than running out of inodes. If you have too few inodes, you could reach the maximum number of files on a disk slice that is practically empty.

Maximum UFS File and File System Size

The maximum size of a UFS file system is approximately 16 terabytes of usable space, minus approximately one percent overhead. A *sparse* file can have a logical size of one terabyte. However, the actual amount of data that can be stored in a file is approximately one percent less than one terabyte because of the file system overhead.

Maximum Number of UFS Subdirectories

The maximum number of subdirectories per directory in a UFS file system is 32,767. This limit is predefined and cannot be changed.

Commands for Creating a Customized File System

This section describes the two commands that you use to create a customized file system:

- `newfs`
- `mkfs`

The `newfs` Command Syntax, Options, and Arguments

The `newfs` command is a friendlier version of the `mkfs` command that is used to create file systems.

The syntax is as follows:

```
/usr/sbin/newfs [-Nv] [mkfs_options] raw_device
```

The following table describes the options and arguments for the `newfs` command.

TABLE 44-4 The `newfs` Command Options and Arguments

Option	Description
-N	Displays the file system parameters that would be used in creating the file system without actually creating it. This option does not display the parameters that were used to create an existing file system.
-T	Set the parameters of the file system to allow eventual growth to over a terabyte in total file system size. This option sets <i>fragsize</i> to be the same as <i>bsize</i> , and sets <i>nbpi</i> to 1 Mbyte, unless the <i>-i</i> option is used to make it even larger. If you use the <i>-f</i> or <i>-i</i> options to specify a <i>fragsize</i> or <i>nbpi</i> that is incompatible with this option, the user-supplied value of <i>fragsize</i> or <i>nbpi</i> is ignored.
-v	Displays the parameters that are passed to the <code>mkfs</code> command.
<i>mkfs-options</i>	Use the options in this table, from <i>-s size</i> to <i>-C maxcontig</i> , to set the <code>mkfs</code> parameters. The options are listed in the order they are passed to the <code>mkfs</code> command. Separate the options with spaces.
<i>-s size</i>	The size of the file system in sectors. The default is automatically determined from the disk label.
<i>-t ntrack</i>	The number of tracks per cylinder on the disk. The default is determined from the disk label.
<i>-b bsize</i>	The logical block size in bytes to use for data transfers. Specify the size of 4096 or 8192 (4 or 8 Kbytes). The default is 8192 bytes (8 Kbytes).
<i>-f fragsize</i>	The smallest amount of disk space in bytes that is allocated to a file. Specify the fragment size in powers of two in the range from 512 to 8192 bytes. The default is 1024 bytes (1 Kbyte). For file systems greater than 1 terabyte or for file systems created with the <i>-T</i> option, <i>fragsize</i> is forced to match block size (<i>bsize</i>).
<i>-c cgsiz</i>	The number of disk cylinders per cylinder group. The default value is calculated by dividing the number of sectors in the file system by the number of sectors in 1 Gbyte, and then multiplying the result by 32. The default value ranges from 16 to 256.
<i>-m free</i>	The minimum percentage of free disk space to allow. The default is $((64 \text{ Mbytes} / \text{partition size}) * 100)$, rounded down to the nearest integer and limited between 1% and 10%, inclusively.

TABLE 44-4 The `newfs` Command Options and Arguments (Continued)

Option	Description
<code>-r rpm</code>	The speed of the disk, in revolutions per minute. This setting is driver- or device-specific. If the drive can report how fast it spins, the <code>mkfs</code> command uses this value. If not, the default is 3600. This parameter is converted to revolutions per second before it is passed to the <code>mkfs</code> command.
<code>-i nbpi</code>	The number of bytes per inode to use in computing how many inodes to create. For the default values, see “Number of Inodes (Files)” on page 645.
<code>-o opt</code>	Optimization type to use for allocating disk blocks to files: <code>space</code> or <code>time</code> . The default is <code>time</code> .
<code>-a apc</code>	The number of alternate blocks per disk cylinder (SCSI devices only) to reserve for bad block placement. The default is 0.
<code>-d gap</code>	(Rotational delay) The expected minimum number of milliseconds it takes the CPU to complete a data transfer and initiate a new data transfer on the same disk cylinder. The default is zero, indicating a disk drive with track readahead buffering.
<code>-n nrpos</code>	The number of different rotation positions in which to divide a cylinder group. The default is 8.
<code>-C maxcontig</code>	<p>The maximum number of blocks, belonging to one file, that will be allocated contiguously before inserting a rotational delay. The default varies from drive to drive. Drives without internal (track) buffers (or drives or controllers that don’t advertise the existence of an internal buffer) default to 1. Drives with buffers default to 7.</p> <p>This parameter is limited in the following way:</p> <p>$blocksize \times maxcontig$ must be $\leq maxphys$</p> <p><i>maxphys</i> is a read-only kernel variable that specifies the maximum block transfer size (in bytes) that the I/O subsystem is capable of satisfying. This limit is enforced by the <code>mount</code> command, not by <code>newfs</code> or <code>mkfs</code> command.</p> <p>This parameter also controls clustering. Regardless of the value of <i>rotdelay</i>, clustering is enabled only when <i>maxcontig</i> is greater than 1. Clustering allows higher I/O rates for sequential I/O and is described in <code>tunefs(1M)</code>.</p>
<code>raw_device</code>	The special character (raw) device file name of the partition that will contain the file system. This argument is required.

Example—`newfs` Command Options and Arguments

This example shows how to use the `-N` option to display file system information, including the backup superblocks.

```
# newfs -N /dev/rdisk/c0t0d0s0
/dev/rdisk/c0t0d0s0: 37260 sectors in 115 cylinders of 9 tracks, 36 sectors
    19.1MB in 8 cyl groups (16 c/g, 2.65MB/g, 1216 i/g)
superblock backups (for fsck -b #) at:
    32, 5264, 10496, 15728, 20960, 26192, 31424, 36656,
#
```

The Generic `mkfs` Command

The generic `mkfs` command calls a file system-specific `mkfs` command, which then creates a file system of a specified type on a specified disk slice. Although the `mkfs` command can support different types of file systems, in practice you would use it to create UFS, UDFS, or PCFS file systems. To make other types of file systems, you would have to write the software for the file system-specific versions of the `mkfs` command to use. Normally, you do not run the `mkfs` command directly. The `mkfs` command is called by the `newfs` command.

The generic `mkfs` command is located in the `/usr/sbin` directory. For a description of the arguments and options, see `mkfs(1M)`.

Backing Up and Restoring Files and File Systems Topics

This topic map lists the chapters that provide information on backing up and restoring files and file systems.

Chapter 46	Provides guidelines and planning information on backing up and restoring files and file systems.
Chapter 47	Provides step-by-step instructions for backing up individual files and complete file systems from local devices or remote devices.
Chapter 48	Provides step-by-step instructions for creating snapshots of UFS file systems.
Chapter 49	Provides step-by-step instructions for restoring individual files and complete file systems.
Chapter 50	Describes how the <code>ufsdump</code> command works, and the syntax and options for the <code>ufsdump</code> and <code>ufsrestore</code> commands.
Chapter 51	Provides step-by-step instructions for using the <code>dd</code> , <code>pax</code> , <code>cpio</code> , and <code>tar</code> commands with different backup media, and for copying files with a different header format.
Chapter 52	Provides step-by-step instructions for how to add a tape device, how to determine the type of tape device and backup device names, and working with magnetic tape cartridges.

Backing Up and Restoring File Systems (Overview)

This chapter provides guidelines and planning information on the backing up and restoring of file systems by using the `ufsdump` and `ufsrestore` commands.

This is a list of the overview information in this chapter.

- “What’s New in Backing Up and Restoring File Systems?” on page 653
- “Where to Find Backup and Restore Tasks” on page 654
- “Definition: Backing Up and Restoring File Systems” on page 654
- “Why You Should Back Up File Systems” on page 655
- “Planning Which File Systems to Back Up” on page 655
- “Choosing the Type of Backup” on page 657
- “Choosing a Tape Device” on page 658
- “High-Level View of Backing Up and Restoring File Systems (Task Map)” on page 659
- “Guidelines for Scheduling Backups” on page 660
- “Sample Backup Schedules” on page 662

What’s New in Backing Up and Restoring File Systems?

This section describes new backup and restore features in the Solaris 9 release.

UFS Snapshots

The Solaris 9 release includes the `fsdump` command for the backing up of file systems while the file system is mounted.

You can use the `fssnap` command to create a read-only snapshot of a file system. A *snapshot* is a file system's temporary image that is intended for backup operations.

For more information, see Chapter 48.

Where to Find Backup and Restore Tasks

Backup or Restore Task	For More Information
Back up file systems with the <code>ufsdump</code> command	Chapter 47
Create UFS snapshots with the <code>fssnap</code> command	Chapter 48
Restore file systems with the <code>ufsrestore</code> command	Chapter 49
Copy files and directories with the <code>cpio</code> , <code>dd</code> , <code>pax</code> , and <code>cpio</code> commands	Chapter 51

Definition: Backing Up and Restoring File Systems

Backing up file systems means the copying of file systems to removable media, such as tape, to safeguard against loss, damage, or corruption. Restoring file systems means the copying of reasonably current backup files from removable media to a working directory.

This chapter describes the `ufsdump` and `ufsrestore` commands for backing up and restoring UFS file systems. Other commands are available for copying files and file systems for the purpose of sharing or transporting files. The following table provides pointers to all commands that copy individual files and file systems to media.

TABLE 46-1 Commands for Backing Up and Restoring Files and File Systems

Task	Command	For More Information
Back up one or more file systems to a local tape device or a remote tape device	<code>ufsdump</code>	Chapter 47 or Chapter 50
Create read-only copies of file systems	<code>fssnap</code>	Chapter 48
Back up all file systems for systems on a network from a backup server	Solstice Backup™ software	<i>Solstice Backup 5.1 Administration Guide</i>
Back up and restore an NIS+ master server	<code>nisbackup</code> and <code>nisrestore</code>	<i>System Administration Guide: Naming and Directory Services (FNS and NIS+)</i>
Copy, list, and retrieve files on tape or diskette	<code>tar</code> , <code>cpio</code> , or <code>pax</code>	Chapter 51
Copy master disk to a clone disk	<code>dd</code>	Chapter 51
Restore complete file systems or individual files from removable media to a working directory	<code>ufsrestore</code>	Chapter 49

Why You Should Back Up File Systems

Backing up files is one of the most crucial system administration functions. You should perform regularly scheduled backups to prevent loss of data due to the following:

- System crashes
- Accidental deletion of files
- Hardware failures
- Natural disasters such as fire, hurricanes, or earthquakes
- Problems when you reinstall or upgrade a system

Planning Which File Systems to Back Up

You should back up all file systems that are critical to users, including file systems that change frequently. The following tables provide general guidelines on the file systems to back up for standalone systems and servers.

TABLE 46-2 File Systems to Back Up for Standalone Systems

File System to Back Up	Description	Back Up Interval
root (/) – slice 0	This file system contains the kernel and possibly contains the /var directory. The /var directory might include frequently modified files such as mail and accounting files.	At regular intervals such as weekly or daily.
/usr – slice 6, /opt	The installation of new software and adding new commands typically affects the /usr and /opt file systems. The /opt directory is either part of root (/) or is its own file system.	Occasionally.
/export/home – slice 7	This file system contains the directories and subdirectories of all users on the standalone system.	More often than root (/) or /usr, perhaps as often as once a day, depending on your site's needs.
/export, /var, or other file systems	During installation of Solaris software, you might have created these file systems.	As your site requires.

TABLE 46-3 File Systems to Back Up for Servers

File System to Back Up	Description	Back Up Interval
root (/) – slice 0	This file system contains the kernel and executables.	Once a day to once a month depending on your site's needs. If you frequently add and remove users and systems on the network, you have to change configuration files in this file system. In this case, you should do a full backup of the root (/) file system at intervals between once a week and once a month. If your site keeps user mail in the /var/mail directory on a mail server, which client systems then mount, you might want to back up root (/) daily. Or, backup the /var directory, if it is a separate file system.

TABLE 46-3 File Systems to Back Up for Servers *(Continued)*

File System to Back Up	Description	Back Up Interval
/export – slice 3	This file system can contain the kernel and executables for diskless clients.	Once a day to once a month depending on your site's needs. Because the information in this file system is similar to the server's root directory in slice 0, the file system does not change frequently. You need to back up this file system only occasionally, unless your site delivers mail to client systems. Then, you should back up /export more frequently.
/usr – slice 6, /opt		Once a day to once a month depending on your site's needs. These file systems are fairly static and need to be backed up once a week to once a month.
/export/home – slice 7	This file system contains the home directories of all the users on the system. The files in this file system are volatile.	Once a day to once a week.

Choosing the Type of Backup

You can perform full or incremental backups with the `ufsdump` command. You can create a temporary image of a file system with the `fsnap` command. The following table lists the differences between these types of backup procedures.

TABLE 46-4 Differences Between Types of Backups

Backup Type	Result	Advantages	Disadvantages
Full	Copies a complete file system or directory	All data is in one place	Requires large numbers of backup tapes that take a long time to write. Takes longer to retrieve individual files because the drive has to move sequentially to the point on the tape where the file is located. You might have to search multiple tapes.
Snapshot	Creates a temporary image of a file system	System can be in multiuser mode	System performance might degrade while the snapshot is created.
Incremental	Copies only those files in the specified file system that have changed since a previous backup	Easier to retrieve small changes in file systems	Finding which incremental tape contains a file can take time. You might have to go back to last full dump.

Choosing a Tape Device

The following table shows typical tape devices that are used for storing file systems during the backup process. The capacity depends on the type of drive and the data being written to the tape. For more detailed information on tape devices, see Chapter 52.

TABLE 46-5 Typical Media for Backing Up File Systems

Media	Capacity
1/2-inch reel tape	140 Mbytes (6250 bpi)
2.5-Gbyte 1/4 inch cartridge (QIC) tape	2.5 Gbytes
DDS3 4-mm cartridge tape (DAT)	12–24 Gbytes
14-Gbyte 8-mm cartridge tape	14 Gbytes
DLT 7000 1/2-inch cartridge tape	35–70 Gbytes

High-Level View of Backing Up and Restoring File Systems (Task Map)

Use this task map to identify all the tasks for the backing up and restoring of file systems. Each task points to a series of additional tasks such as determining the type of backup to perform.

Task	Description	For Instructions
1. Identify the file systems to back up	Identify which file systems need to be backed up on a daily, weekly, or monthly basis.	"Planning Which File Systems to Back Up" on page 655
2. Determine the type of backup	Determine the type of backup you need for the file systems at your site.	"Choosing the Type of Backup" on page 657
3. Create the backup	Use one of the following methods: If you want to have full and incremental backups of your file systems, use the <code>ufsdump</code> command. If you would like to create a snapshot of file system while it is active and mounted, consider using the <code>fsnap</code> command. If you just want to have full backups of your personal home directory or smaller, less-important file systems, use the <code>tar</code> , <code>cpio</code> , or <code>pax</code> commands.	Chapter 47 Chapter 48 Chapter 51
4. Restore a file system	(Optional) Select the restoration method that is based on the command used to back up the files or file system.	
	Restore a file system backup that was created with the <code>ufsdump</code> command.	Chapter 49
	Restore a file system that was created with the <code>tar</code> , <code>cpio</code> , or <code>pax</code> command.	Chapter 51

Task	Description	For Instructions
5. Restore the root (/) or /usr file system	Optional Restoring the root (/) or /usr file system is more complicated than restoring a non-critical file system because you need to boot from a local CD or from the network while these file systems are being restored.	"How to Restore the root (/) and /usr File Systems" on page 700

Guidelines for Scheduling Backups

A *backup schedule* is the schedule that you establish to run the `ufsdump` command. This section discusses guidelines on the factors to weigh when you create a backup schedule and how often to back up file systems. This section also includes sample backup schedules.

The backup schedule that you create depends on the following:

- Your need to minimize the number of tapes that are used for backups
- Time available for doing backups
- Time available for doing a full restore of a damaged file system
- Time available for retrieving individual files that are accidentally deleted

How Often Should You Do Backups?

If you do not need to minimize time and the amount of media that is used for backups, you can do full backups every day. However, this backup method is not realistic for most sites, so incremental backups are used most often. In this case, you should back up your site enough to restore files from the last four weeks. This schedule requires at least four sets of tapes—one for each week, which you would reuse each month. In addition, you should archive the monthly backups for at least a year, and then keep yearly backups for a number of years.

Using Dump Levels to Create Incremental Backups

The dump level you specify in the `ufsdump` command (0-9) determines which files are backed up. Dump level 0 creates a full backup. Levels 1–9 are used to schedule incremental backups, but have *no defined meanings*. Levels 1–9 are just a range of numbers that are used to schedule cumulative or discrete backups. The only meaning levels 1–9 have is in relationship to each other, as a higher or lower number.

The following examples show the flexibility of the incremental dump procedure using levels 1–9.

Dump Levels for Daily, Cumulative Backups

Doing daily, cumulative incremental backups is the most commonly used backup scheme and is recommended for most situations. The following example shows a schedule that uses a level 9 dump each day, and a level 5 dump on Friday to restart the process.

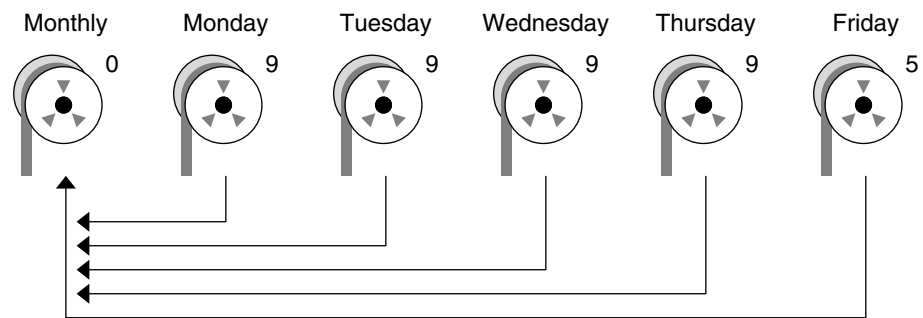

FIGURE 46-1 Incremental Backup: Daily Cumulative

In the preceding example, you could have used other numbers in the 1–9 range to produce the same results. The key is having the same number each day, with any *lower* number on Friday. For example, you could have specified levels 4, 4, 4, 4, 2 or 7, 7, 7, 7, 5.

Dump Levels for Daily, Discrete Backups

The following example shows a schedule where you capture only a day's work on different tapes. In this case, sequential dump level numbers are used during the week (3,4,5,6) with a lower number (2) on Friday.

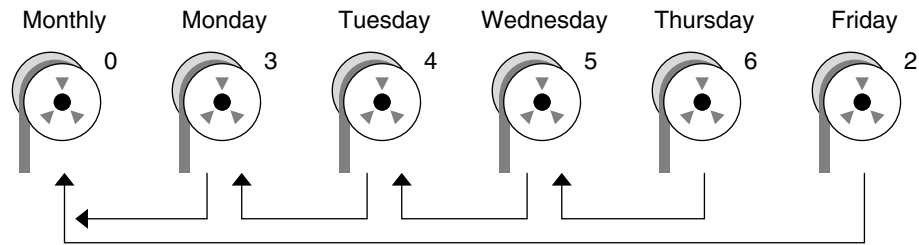

FIGURE 46-2 Incremental Backup: Daily Discrete

In the preceding example, you could have used the sequence 6, 7, 8, 9 followed by 2, or 5, 6, 7, 8 followed by 3. Remember, the numbers themselves have no defined meaning. You attribute meaning by ordering them in a high/low sequence.

Sample Backup Schedules

This section provides sample backup schedules. All schedules assume that you begin with a full backup (dump level 0), and that you use the `-u` option to record each backup.

Example—Daily Cumulative, Weekly Cumulative Backups

The following table shows the most commonly used incremental backup schedule. This schedule is recommended for most situations. With this schedule, the following occurs:

- All files that have changed since the lower-level backup at the end of the previous week are saved each day.
- For each weekday level 9 backup, the previous level 0 or level 5 is the closest backup at a lower level. Therefore, each weekday tape contains all the files that changed since the end of the previous week or the initial level 0 for the first week.
- For each Friday level 5 backup, the nearest lower-level backup is the level 0 done at the beginning of the month. Therefore, each Friday's tape contains all the files changed during the month to that point.

TABLE 46-6 Daily Cumulative or Weekly Cumulative Backup Schedule

	Floating	Mon	Tues	Wed	Thurs	Fri
1st of Month	0					
Week 1		9	9	9	9	5
Week 2		9	9	9	9	5
Week 3		9	9	9	9	5
Week 4		9	9	9	9	5

The following table shows how the contents of the tapes can change across two weeks with the daily cumulative, weekly cumulative schedule. Each letter represents a different file.

TABLE 46-7 Contents of Tapes for Daily Cumulative/Weekly Cumulative Backup Schedule

	Mon	Tues	Wed	Thurs	Fri
Week 1	a b	a b c	a b c d	a b c d e	a b c d e f
Week 2	g	g h	g h i	g h i j	a b c d e f g h i j k

Tape Requirements for the Daily Cumulative, Weekly Cumulative Schedule

With this schedule, you need six tapes if you want to reuse daily tapes, or nine tapes if you want to use four different daily tapes: one tape for the level 0, four tapes for Fridays, and one or four daily tapes.

If you need to restore a complete file system, you need the following tapes: the level 0, the most recent Friday tape, and the most recent daily tape since the last Friday tape, if any.

Example—Daily Cumulative, Weekly Incremental Backups

The following table shows a schedule where each weekday tape accumulates all files that changed since the beginning of the week, or the initial level 0 for the first week, and each Friday's tape contains all the files that changed that week.

TABLE 46-8 Daily Cumulative, Weekly Incremental Backup Schedule

	Floating	Mon	Tues	Wed	Thurs	Fri
1st of Month	0					
Week 1		9	9	9	9	3
Week 2		9	9	9	9	4
Week 3		9	9	9	9	5
Week 4		9	9	9	9	6

The following table shows how the contents of the tapes can change across two weeks with the daily cumulative, weekly incremental backup schedule. Each letter represents a different file.

TABLE 46-9 Contents of Tapes for Daily Cumulative, Weekly Incremental Backup Schedule

	Mon	Tues	Wed	Thurs	Fri
Week 1	a b	a b c	a b c d	a b c d e	a b c d e f
Week 2	g	g h	g h i	g h i j	g h i j k

Tape Requirements for the Daily Cumulative, Weekly Incremental Backup Schedule

With this schedule, you need six tapes, if you want to reuse daily tapes, or nine tapes, if you want to use four different daily tapes: one tape for the level 0, four tapes for Fridays, and one or four daily tapes.

If you need to restore a complete file system, you need the following tapes: the level 0, all the Friday tapes, and the most recent daily tape since the last Friday tape, if any.

Example—Daily Incremental, Weekly Cumulative Backups

The following table shows a schedule where each weekday tape contains only the files that changed since the previous day, and each Friday's tape contains all files changed since the initial level 0 at the beginning of the month.

TABLE 46–10 Daily Incremental, Weekly Cumulative Backup Schedule

	Floating	Mon	Tues	Wed	Thurs	Fri
1st of Month	0					
Week 1		3	4	5	6	2
Week 2		3	4	5	6	2
Week 3		3	4	5	6	2
Week 4		3	4	5	6	2

The following table shows how the contents of the tapes can change across two weeks with the daily incremental, weekly cumulative schedule. Each letter represents a different file.

TABLE 46–11 Contents of Tapes for Daily Incremental, Weekly Cumulative Backup Schedule

	Mon	Tues	Wed	Thurs	Fri
Week 1	a b	c d	e f g	h i	a b c d e f g h i
Week 2	j k l	m	n o	p q	a b c d e f g h i j k l m n o p q r s

Tape Requirements for Daily Incremental, Weekly Cumulative Schedule

With this schedule, you need at least nine tapes if you want to reuse daily tapes, which is not recommended. Or, you need 21 tapes if you save weekly tapes for a month: one tape for the level 0, four tapes for the Fridays, and four or 16 daily tapes.

If you need to restore the complete file system, you need the following tapes: the level 0, the most recent Friday tape, and all the daily tapes since the last Friday tape, if any.

Example—Monthly Backup Schedule for a Server

The following table shows an example backup strategy for a heavily used file server on a small network where users are doing file-intensive work, such as program development or document production. This example assumes that the backup period begins on a Sunday and consists of four seven-day weeks.

TABLE 46-12 Example of Monthly Backup Schedule for a Server

Directory	Date	Level	Tape Name
root (/)	1st Sunday	0	<i>n</i> tapes
/usr	1st Sunday	0	<i>n</i> tapes
/export	1st Sunday	0	<i>n</i> tapes
/export/home	1st Sunday	0	<i>n</i> tapes
	1st Monday	9	A
	1st Tuesday	9	B
	1st Wednesday	5	C
	1st Thursday	9	D
	1st Friday	9	E
	1st Saturday	5	F
root (/)	2nd Sunday	0	<i>n</i> tapes
/usr	2nd Sunday	0	"
/export	2nd Sunday	0	"
/export/home	2nd Sunday	0	"
	2nd Monday	9	G
	2nd Tuesday	9	H
	2nd Wednesday	5	I
	2nd Thursday	9	J
	2nd Friday	9	K
	2nd Saturday	5	L
root (/)	3rd Sunday	0	<i>n</i> tapes
/usr	3rd Sunday	0	"
/export	3rd Sunday	0	"
/export/home	3rd Sunday	0	"
	3rd Monday	9	M
	3rd Tuesday	9	N
	3rd Wednesday	5	O
	3rd Thursday	9	P

TABLE 46–12 Example of Monthly Backup Schedule for a Server (Continued)

Directory	Date	Level	Tape Name
	3rd Friday	9	Q
	3rd Saturday	5	R
root (/)	4th Sunday	0	<i>n</i> tapes
/usr	4th Sunday	0	"
/export	4th Sunday	0	"
/export/home	4th Sunday	0	"
	4th Monday	9	S
	4th Tuesday	9	T
	4th Wednesday	5	U
	4th Thursday	9	V
	4th Friday	9	W
	4th Saturday	5	X

With this schedule, you use $4n$ tapes, the number of tapes needed for four full backups of the root (/), /usr, /export, and /export/home file systems, plus 24 additional tapes for the incremental backups of the /export/home file systems. This schedule assumes that each incremental backup uses one tape and that you save the tapes for a month.

Here's how this schedule works:

1. On each Sunday, do a full backup (level 0) of the root (/), /usr, /export, and /export/home file systems. Save the level 0 tapes for at least 3 months.
2. On the first Monday of the month, use tape A to do a level 9 backup of the /export/home file system. The `ufsdump` command copies all files changed since the previous lower-level backup. In this case, the level 0 backup that you did on Sunday.
3. On the first Tuesday of the month, use tape B to do a level 9 backup of the /export/home file system. Again, the `ufsdump` command copies all files changed since the last lower-level backup, which is Sunday's level 0 backup.
4. On the first Wednesday, use tape C to do a level 5 backup. The `ufsdump` command copies all files that changed since Sunday.
5. Do the Thursday and Friday level 9 backups on tapes D and E. The `ufsdump` command copies all files that changed since the last lower-level backup, which is Wednesday's level 5 backup.

6. On the first Saturday of the month, do a level 5 backup of `/export/home`, which copies all files changed since the previous lower-level backup (in this case, the level 0 backup you did on Sunday). Store tapes A-F until the first Monday of the next 4-week period, when you use them again.
7. Repeat steps 1–6 for the next three weeks, using tapes G-L and $4n$ tapes for the level 0 on Sunday, and so on.
8. For each 4-week period, repeat steps 1–7, using a new set of tapes for the level 0s and reusing tapes A–X for the incremental backups. The level 0 tapes could be reused after 3 months.

This schedule lets you save files in their various states for a month. This plan requires many tapes, but ensures that you have a library of tapes to draw upon. To reduce the number of tapes, you could reuse Tapes A-F each week.

Suggestions for Scheduling Backups

The following table provides other suggestions for scheduling backups.

TABLE 46-13 Suggestions for Backup Schedules

File Restoration Need	Backup Interval	Comments
To restore different versions of files (for example, file systems that are used for word processing)	<ul style="list-style-type: none"> ■ Do daily incremental backups every working day. ■ Do <i>not</i> reuse the same tape for daily incremental backups. 	This schedule saves all files modified that day, as well as those files still on disk that were modified since the last backup of a lower level. However, with this schedule, you should use a different tape each day because a file that changed on Tuesday, and again on Thursday, goes onto Friday's lower-level backup looking like it did Thursday night—not Tuesday night. If a user needs the Tuesday version, you cannot restore it unless you have a Tuesday backup tape (or a Wednesday backup tape). Similarly, a file that is present on Tuesday and Wednesday, but removed on Thursday, does not appear on the Friday lower-level backup.
To quickly restore a complete file system	Do lower-level backups more frequently.	—
To backup a number of file systems on the same server	Consider offsetting the schedule for different file systems.	This way you're not doing all level 0 backups on the same day.

TABLE 46-13 Suggestions for Backup Schedules *(Continued)*

File Restoration Need	Backup Interval	Comments
To minimize tapes	Increase the level of incremental backups that are done across the week.	Only changes from day to day are saved on each daily tape.
	Increase the level of backups that are done at the end of the week. Put each day's and week's incremental backups onto the same tape.	Only changes from week to week (rather than the entire month) are saved on the weekly tapes.
	Put each day's and week's incremental backups onto the same tape.	To do so, use the no rewind option in the <code>ufsdump</code> command.

Backing Up Files and File Systems (Tasks)

This chapter describes the procedures for backing up file systems by using the `ufsdump` command.

For information on these procedures, see “Backing Up Files and File System (Task Map)” on page 671.

For overview information about performing backups, see Chapter 46.

For detailed information on `ufsdump` syntax, options, and arguments, see Chapter 50.

Backing Up Files and File System (Task Map)

Task	Description	For Instructions
1. Prepare for file system backups	Identify the file systems, the type of backup, and the tape device to be used for the backups.	“Preparing for File System Backups” on page 672
2. Determine the number of tapes needed to back up a file system	Determine the number of tapes that are needed for a full backup of a file system.	“How to Determine the Number of Tapes Needed for a Full Backup” on page 673

Task	Description	For Instructions
3. Back up your file systems	<p>Perform a full backup of your file systems to get baseline copies of all files.</p> <p>Perform an incremental backup of your file systems based on whether keeping copies of files that have changed on a daily basis is important at your site.</p>	“How to Backup a File System to Tape” on page 674

Preparing for File System Backups

The preparation for backing up file systems begins with planning, which is described in Chapter 46 and includes choosing the following:

- The file systems to back up
- The type of backup (full or incremental) to perform
- A backup schedule
- A tape drive

This section describes other tasks you might need to perform before you back up file systems, including the following:

- Finding names of file systems to back up
- Determining the number of tapes that are needed for a full backup

▼ How to Find File System Names

1. Display the contents of the `/etc/vfstab` file.

```
$ more /etc/vfstab
```

2. Look in the `mount point` column for the name of the file system.
3. Use the directory name listed in the `mount point` column when you back up the file system.

Example—Finding File System Names

The file systems to be backed up in this example are root (`/`), `/usr`, `/datab`, and `/export/home`.

```
$ more /etc/vfstab
#device          device          mount          FS    fsck mount      mount
```

#to mount	to fsck	point	type	pass	at boot	options
#						
fd	-	/dev/fd	fd	-	no	-
/proc	-	/proc	proc	-	no	-
/dev/dsk/c0t0d0s1	-	-	swap	-	no	-
/dev/dsk/c0t0d0s0	/dev/rdisk/c0t0d0s0	/	ufs	1	no	-
/dev/dsk/c0t0d0s6	/dev/rdisk/c0t0d0s6	/usr	ufs	1	no	-
/dev/dsk/c0t0d0s5	/dev/rdisk/c0t0d0s5	/datab	ufs	2	yes	-
/dev/dsk/c0t0d0s7	/dev/rdisk/c0t0d0s7	/export/home	ufs	2	yes	-
swap	-	/tmp	tmpfs	-	yes	-

▼ How to Determine the Number of Tapes Needed for a Full Backup

1. Become superuser or assume an equivalent role.
2. Estimate the size of the backup in bytes.

```
# ufsdump S file-system
```

The S displays the estimated number of bytes that are needed to do the backup.

3. Divide the estimated size by the capacity of the tape to see how many tapes you need.

For a list of tape capacities, see Table 46–5.

Example—Determining Number of Tapes

In this example, the file system of 489,472 bytes easily fits on a 150-Mbyte tape.

```
# ufsdump S /export/home
489472
```

Backing Up a File System

The following are general guidelines for performing backups:

- Use single-user mode or unmount the file system, unless you are creating a snapshot of a file system. For information about UFS snapshots, see Chapter 48.
- Be aware that the backing up of file systems when there are directory-level operations (such as creating, removing, and renaming files) and file-level activity occurring means that some data will not be included in the backup.
- You can run the `ufsdump` command from a single system and remotely back up groups of systems across the network through remote shell or remote login, and direct the output to the system on which the tape drive is located. (Typically, the

tape drive is located on the system from which you run the `ufsdump` command, but it does not have to be.)

Another way to back up files to a remote drive is to pipe the output from the `ufsdump` command to the `dd` command. For information about using the `dd` command, see Chapter 51.

- If you are doing remote backups across the network, the system with the tape drive must have entries in its `.rhosts` file for each client that will be using the drive. Also, the system that initiates the backup must be included in the `.rhosts` file on each system that it will back up.
- To specify a remote tape device on a system, use the naming convention that matches the OS release of the system with the remote tape drive. For example, use the `/dev/rst0` device for a remote drive on a system that is running the SunOS 4.1.1 release or compatible versions. Use the `/dev/rmt/0` device for a system running the Solaris 9 release or compatible versions.

Note – Use the `nisbackup` command to back up a NIS+ master server. For information on using this command, see *System Administration Guide: Naming and Directory Services (FNS and NIS+)*.

▼ How to Backup a File System to Tape

The following steps provide the general steps for backing up file systems using the `ufsdump` command. The examples show specific uses of options and arguments.

1. **Become superuser or assume an equivalent role.**
2. **Bring the system to run level S (single-user mode).**

```
# shutdown -g30 -y
```

3. **(Optional) Check the file system for consistency.**

```
# fsck -m /dev/rdisk/device-name
```

The `fsck -m` command checks for the consistency of file systems. For example, power failures can leave files in an inconsistent state. For more information on the `fsck` command, see Chapter 43.

4. **If you need to back up file systems to a remote tape drive:**
 - a. **On the system to which the tape drive is attached (the tape server), add the following entry to its `.rhosts` file.**

```
host root
```

The `host` entry specifies the name of the system on which you will run the `ufsdump` command to perform the backup.

- b. On the tape server, verify that the host added to the `/.rhosts` file is accessible through the name service.
5. Identify the device name of the tape drive.
The default tape drive is the `/dev/rmt/0` device.
 6. Insert a tape that is not write-protected into the tape drive.
 7. Back up file systems.

```
# ufsdump options arguments filenames
```

The following examples show how to use the most common `ufsdump` options and arguments:
 - “Example—Performing a Full Backup of root (/)” on page 675
 - “Example—Performing an Incremental Backup of root (/)” on page 676
 - “Example—Performing a Full Backup, Individual Home Directory” on page 677
 - “Example—Performing a Full Backup to Remote System (Solaris 9 Data to Solaris 9 System)” on page 678
 For other `ufsdump` options and arguments, see Chapter 50.
 8. If prompted, remove the tape and insert the next tape volume.
 9. Label each tape with the volume number, dump level, date, system name, disk slice, and file system.
 10. Bring the system back to run level 3 by pressing Control-D.
 11. Verify that the backup was successful.

```
# ufsrestore tf device-name
```

Example—Performing a Full Backup of root (/)

The following example shows how to do a full backup of the root (/) file system. The system in this example is brought to single-user mode before the backup. The following `ufsdump` options are included:

- `0` specifies that this is a 0 level dump (or a full backup)
 - `u` specifies that the `/etc/dumpdates` file is updated with the date of this backup
 - `c` identifies a cartridge tape device
 - `f /dev/rmt/0` identifies the tape device
 - `/` is the file system being backed up
- ```
shutdown -g30 -y
ufsdump 0ucf /dev/rmt/0 /
DUMP: Writing 63 Kilobyte records
DUMP: Date of this level 0 dump: Wed Sep 05 13:27:20 2001
DUMP: Date of last level 0 dump: the epoch
```

```

DUMP: Dumping /dev/rdsk/c0t1d0s0 (earth:/) to /dev/rmt/0.
DUMP: Mapping (Pass I) [regular files]
DUMP: Mapping (Pass II) [directories]
DUMP: Estimated 57150 blocks (27.91MB).
DUMP: Dumping (Pass III) [directories]
DUMP: Dumping (Pass IV) [regular files]
DUMP: Tape rewinding
DUMP: 57076 blocks (27.87MB) on 1 volume at 265 KB/sec
DUMP: DUMP IS DONE
DUMP: Level 0 dump on Wed Sep 05 13:27:20 2001
ufsrestore tf /dev/rmt/0
 2 .
 3 ./lost+found
 3776 ./usr
 7552 ./var
11328 ./export
15104 ./export/home
18880 ./etc
22656 ./etc/default
22657 ./etc/default/sys-suspend
22673 ./etc/default/cron
22674 ./etc/default/devfsadm
22675 ./etc/default/dhccpagent
22676 ./etc/default/fs
22677 ./etc/default/inetinit
22678 ./etc/default/kbd
22679 ./etc/default/mpathd
22680 ./etc/default/nfslogd
22681 ./etc/default/passwd
 .
 .
 .
(Press Control-d to bring system to run level 3)

```

## Example—Performing an Incremental Backup of root (/)

The following example shows how to do an incremental backup of the root (/) file system. The following `ufsdump` options are included:

- 9 specifies that this is a 9 level dump (or an incremental backup)
- u specifies that the `/etc/dumpdates` file is updated with the date of this backup
- c identifies a cartridge tape device
- f `/dev/rmt/0` identifies the tape device
- / is the file system being backed up

```

ufsdump 9ucf /dev/rmt/0 /
DUMP: Writing 63 Kilobyte records
DUMP: Date of this level 9 dump: Fri Jul 13 10:58:12 2001
DUMP: Date of last level 0 dump: Fri Jul 13 10:46:09 2001
DUMP: Dumping /dev/rdsk/c0t0d0s0 (starbug:/) to /dev/rmt/0.
DUMP: Mapping (Pass I) [regular files]

```

```

DUMP: Mapping (Pass II) [directories]
DUMP: Mapping (Pass II) [directories]
DUMP: Mapping (Pass II) [directories]
DUMP: Mapping (Pass II) [directories]
DUMP: Estimated 200 blocks (100KB).
DUMP: Dumping (Pass III) [directories]
DUMP: Dumping (Pass IV) [regular files]
DUMP: Tape rewinding
DUMP: 124 blocks (62KB) on 1 volume at 8 KB/sec
DUMP: DUMP IS DONE
DUMP: Level 9 dump on Fri Jul 13 10:58:12 2001
ufsrestore tf /dev/rmt/0
 2 .
 3 ./lost+found
 5696 ./usr
11392 ./var
17088 ./export
22784 ./export/home
28480 ./opt
 5697 ./etc
11393 ./etc/default
11394 ./etc/default/sys-suspend
11429 ./etc/default/cron
11430 ./etc/default/devfsadm
11431 ./etc/default/dhcpagent
11432 ./etc/default/fs
11433 ./etc/default/inetinit
11434 ./etc/default/kbd
11435 ./etc/default/nfslogd
11436 ./etc/default/passwd
11437 ./etc/default/tar
 .
 .
 .

```

## Example—Performing a Full Backup, Individual Home Directory

The following example shows how to do a full backup of the `/export/home/kryten` directory. The following `ufsdump` options are included:

- `0` specifies that this is a 0 level dump (or a full backup)
- `u` specifies that the `/etc/dumpdates` file is updated with the date of this backup
- `c` identifies a cartridge tape device
- `f /dev/rmt/0` identifies the tape device
- `/export/home/kryten` is the directory being backed up

```

ufsdump 0ucf /dev/rmt/0 /export/home/kryten
DUMP: Writing 63 Kilobyte records
DUMP: Date of this level 0 dump: Fri Jul 13 11:30:45 2001

```

```

DUMP: Date of last level 0 dump: the epoch
DUMP: Dumping /dev/rdisk/c0t3d0s7 (pluto:/export/home) to /dev/rmt/0.
DUMP: Mapping (Pass I) [regular files]
DUMP: Mapping (Pass II) [directories]
DUMP: Estimated 232 blocks (116KB).
DUMP: Dumping (Pass III) [directories]
DUMP: Dumping (Pass IV) [regular files]
DUMP: Tape rewinding
DUMP: 124 blocks (62KB) on 1 volume at 8 KB/sec
DUMP: DUMP IS DONE
ufsrestore tf /dev/rmt/0
 2 .
2688 ./kryten
5409 ./kryten/letters
5410 ./kryten/letters/letter1
5411 ./kryten/letters/letter2
5412 ./kryten/letters/letter3
2689 ./kryten/.profile
8096 ./kryten/memos
 30 ./kryten/reports
 31 ./kryten/reports/reportA
 32 ./kryten/reports/reportB
 33 ./kryten/reports/reportC
#

```

## Example—Performing a Full Backup to Remote System (Solaris 9 Data to Solaris 9 System)

The following example shows how to do a full backup of a local `/export/home` file system on a Solaris 9 system (`starbug`) to a tape device on a remote Solaris 9 system (`earth`). The following `ufsdump` options are included:

- `0` specifies that this is a 0 level dump (or a full backup)
- `u` specifies that the `/etc/dumpdates` file is updated with the date of this backup
- `c` identifies a cartridge tape device
- `f earth:/dev/rmt/0` identifies the remote system name and tape device
- `/export/home` is the file system being backed up

```

ufsdump 0ucf earth:/dev/rmt/0 /export/home
DUMP: Writing 63 Kilobyte records
DUMP: Date of this level 0 dump: Wed Sep 05 14:52:31 2001
DUMP: Date of last level 0 dump: the epoch
DUMP: Dumping /dev/rdisk/c0t0d0s7 (starbug:/export/home) to earth:/dev ...
DUMP: Mapping (Pass I) [regular files]
DUMP: Mapping (Pass II) [directories]
DUMP: Estimated 266 blocks (133KB).
DUMP: Dumping (Pass III) [directories]
DUMP: Dumping (Pass IV) [regular files]
DUMP: Tape rewinding
DUMP: 250 blocks (125KB) on 1 volume at 247 KB/sec

```

```
DUMP: DUMP IS DONE
DUMP: Level 0 dump on Wed Sep 05 14:52:31 2001
ufsrestore tf earth:/dev/rmt/0
 2 .
 3 ./lost+found
 7168 ./rimmer
 7169 ./rimmer/.profile
21504 ./rimmer/skdir
21505 ./rimmer/skdir/scd557
21506 ./rimmer/skdir/scd772
10752 ./lister
10753 ./lister/.profile
10754 ./lister/filea
10755 ./lister/fileb
10756 ./lister/filec
14336 ./pmorph
14337 ./pmorph/.profile
 3584 ./pmorph/bigdir
 3585 ./pmorph/bigdir/bigfile
17920 ./pmorph/smalldir
17921 ./pmorph/smalldir/smallfile
#
```





---

## Using UFS Snapshots (Tasks)

---

This chapter describes how to create and back up UFS snapshots.

For information on the procedures associated with creating UFS snapshots, see “Using UFS Snapshots (Task Map)” on page 681.

For overview information about performing backups, see Chapter 46.

---

## Using UFS Snapshots (Task Map)

| Task                                | Description                                                                   | For Instructions                                                                     |
|-------------------------------------|-------------------------------------------------------------------------------|--------------------------------------------------------------------------------------|
| 1. Create a UFS snapshot            | Create a read-only copy of a file system with the <code>fsnap</code> command. | “How to Create a UFS Snapshot” on page 684                                           |
| 2. Display UFS snapshot information | Identify UFS snapshot information such as the raw snapshot device.            | “How to Display UFS Snapshot Information” on page 684                                |
| 3. (Optional) Delete a UFS snapshot | Delete a snapshot that is already backed up or no longer needed.              | “How to Delete a UFS Snapshot” on page 685                                           |
| 4. Back up a UFS snapshot           | Choose one of the following backup methods:                                   |                                                                                      |
|                                     | Create a full backup of a UFS snapshot with the <code>ufsdump</code> command. | “How to Create a Full Backup of a UFS Snapshot ( <code>ufsdump</code> )” on page 686 |

| Task                                           | Description                                                                                               | For Instructions                                                                             |
|------------------------------------------------|-----------------------------------------------------------------------------------------------------------|----------------------------------------------------------------------------------------------|
|                                                | Create an incremental backup of a UFS snapshot with the <code>ufsdump</code> command.                     | "How to Create an Incremental Backup of a UFS Snapshot ( <code>ufsdump</code> )" on page 687 |
|                                                | Back up a UFS snapshot with the <code>tar</code> command.                                                 | "How to Back Up a UFS Snapshot ( <code>tar</code> )" on page 688                             |
| 5. (Optional) Restore data from a UFS snapshot | Restore the UFS snapshot the same way as you would restore data with the <code>ufsrestore</code> command. | "How to Restore a Complete File System" on page 697                                          |

---

## UFS Snapshots Overview

The Solaris release includes the `fssnap` command for backing up file systems while the file system is mounted. You can use the `fssnap` command to create a read-only snapshot of a file system. A *snapshot* is a file system's temporary image that is intended for backup operations.

When the `fssnap` command is run, it creates a virtual device and a backing-store file. You can back up the *virtual device*, which looks and acts like a real device, with any of the existing Solaris backup commands. The *backing-store* file is a bitmapped file that contains copies of pre-snapshot data that has been modified since the snapshot was taken.

### Why Use UFS Snapshots?

UFS snapshots enables you to keep the file system mounted and the system in multiuser mode during backups. Previously, you were advised to bring the system to single-user mode to keep the file system inactive when you used the `ufsdump` command to perform backups. You can also use additional Solaris backup commands like `tar` and `cpio` to back up a UFS snapshot for more reliable backups.

The `fssnap` command gives administrators of non-enterprise-level systems the power of enterprise-level tools like Sun StorEdge™ Instant Image without the large storage demands.

UFS snapshots is similar to the Instant Image product. Instant Image allocates space equal to the size of the entire file system that is being captured. However, the backing-store file that is created by UFS snapshots occupies only as much disk space as needed, and you can place a maximum size on the backing-store file.

This table describes specific differences between UFS snapshots and Instant Image.

| UFS Snapshots                                                                                    | Instant Image                                                                                    |
|--------------------------------------------------------------------------------------------------|--------------------------------------------------------------------------------------------------|
| Size of the backing-store file depends on how much data has changed since the snapshot was taken | Size of the backing-store file equivalent equals the size of the entire file system being copied |
| Does not persist across system reboots                                                           | Persists across system reboots                                                                   |
| Works on UFS file systems                                                                        | Cannot be used with root (/) or /usr file systems                                                |
| Starting with the Solaris 8 1/01 release                                                         | Part of Sun StorEdge products                                                                    |

Although UFS snapshots can make copies of large file systems, Instant Image is better suited for enterprise-level systems. UFS snapshots is better suited for smaller systems.

## UFS Snapshots Performance Issues

When the UFS snapshot is first created, users of the file system might notice a slight pause. The length of the pause increases with the size of the file system to be captured. While the snapshot is active, users of the file system might notice a slight performance impact when the file system is written to, but they will see no impact when the file system is read.

---

## Creating and Deleting UFS Snapshots

When you use the `fsnap` command to create a UFS snapshot, observe how much disk space the backing-store file consumes. The backing-store file uses no space, and then it grows quickly, especially on heavily used systems. Make sure the backing-store file has enough space to grow, or limit its size with the `-o maxsize=n [k, m, g]` option, where *n* [k, m, g] is the maximum size of the backing-store file.



---

**Caution** – If the backing-store file runs out of space, the snapshot might delete itself, which causes the backup to fail. Check the `/var/adm/messages` file for possible snapshot errors.

---

For more information, see `fsnap_ufs(1M)`.

## ▼ How to Create a UFS Snapshot

1. Become superuser or assume an equivalent role.
2. Make sure that the file system has enough disk space for the backing-store file.

```
df -k
```

3. Make sure that a backing-store file of the same name and location does not already exist.

```
ls /backing-store-file
```

4. Create the UFS snapshot.

```
fssnap -F ufs -o bs=/backing-store-file /file-system
```

---

**Note** – The backing-store file must reside on a different file system than the file system that is being snapshot.

---

5. Verify that the snapshot has been created.

```
/usr/lib/fs/ufs/fssnap -i /file-system
```

## Examples—Creating a UFS Snapshot

The following example shows how to create a snapshot of the `/usr` file system. The backing-store file is `/scratch/usr.back.file`, and the virtual device is `/dev/fssnap/1`.

```
fssnap -F ufs -o bs=/scratch/usr.back.file /usr
/dev/fssnap/1
```

The following example shows how to limit the backing-store file to 500 Mbytes.

```
fssnap -F ufs -o maxsize=500m,bs=/scratch/usr.back.file /export/home
/dev/fssnap/1
```

## ▼ How to Display UFS Snapshot Information

You can display the current snapshots on the system by using the `fssnap -i` option. If you specify a file system, you see detailed information about that snapshot. If you don't specify a file system, you see information about all of the current UFS snapshots and their corresponding virtual devices.

---

**Note** – Use the UFS file system-specific `fssnap` command to view the extended snapshot information as shown in the following examples.

---

**1. Become superuser or assume an equivalent role.**

**2. List current snapshots.**

```
/usr/lib/fs/ufs/fssnap -i
Snapshot number : 0
Block Device : /dev/fssnap/0
Raw Device : /dev/rfssnap/0
Mount point : /export/home
Device state : idle
Backing store path : /var/tmp/bs.file
Backing store size : 0 KB
Maximum backing store size : Unlimited
Snapshot create time : Wed Aug 29 15:22:06 2001
Copy-on-write granularity : 32 KB
```

To display detailed information about a specific snapshot, use the following:

```
/usr/lib/fs/ufs/fssnap -i /usr
Snapshot number : 0
Block Device : /dev/fssnap/0
Raw Device : /dev/rfssnap/0
Mount point : /usr
Device state : idle
Backing store path : /var/tmp/bs.file
Backing store size : 0 KB
Maximum backing store size : Unlimited
Snapshot create time : Wed Aug 29 15:23:35 2001
Copy-on-write granularity : 32 KB
```

## Deleting a UFS Snapshot

When you create a UFS snapshot, you can specify that the backing-store file is unlinked, which means that the backing-store file is removed after the snapshot is deleted. If you don't specify the `-o unlink` option when you create a UFS snapshot, you will have to delete it manually.

The backing-store file occupies disk space until the snapshot is deleted, whether you use the `-o unlink` option to remove the backing-store file or you remove it manually.

### ▼ How to Delete a UFS Snapshot

You can delete a snapshot either by rebooting the system or by using the `fssnap -d` command and specifying the path of the file system that contains the UFS snapshot.

1. **Become superuser or assume an equivalent role.**

2. **Identify the snapshot to be deleted.**

```
/usr/lib/fs/ufs/fssnap -i
```

3. **Delete the snapshot.**

```
fssnap -d /file-system
Deleted snapshot 1.
```

4. **(Optional) If you did not use the `-o unlink` option when you created the snapshot, you need to delete the backing-store file manually.**

```
rm /file-system/backing-store-file
```

## Example—Deleting a UFS Snapshot

The following example shows how to delete a snapshot and assumes that the `unlink` option was not used.

```
fssnap -i
0 / 1 /usr
fssnap -d /usr
Deleted snapshot 1.
rm /scratch/usr.back.file
```

---

## Backing Up a UFS Snapshot

You can create a full or incremental back up of UFS snapshot. You can use the standard Solaris backup commands to back up a UFS snapshot.

The virtual device that contains the UFS snapshot acts as a standard read-only device. This means you can back up the virtual device as if you were backing up a file system device.

If you are using the `ufsdump` command to back up a UFS snapshot, you can specify the snapshot name during the backup. See the following section for more information.

### ▼ How to Create a Full Backup of a UFS Snapshot (`ufsdump`)

1. **Become superuser or assume an equivalent role.**

2. **Identify the UFS snapshot to be backed up.**

```
/usr/lib/fs/ufs/fssnap -i /file-system
```

For example:

```
/usr/lib/fs/ufs/fssnap -i /usr
Snapshot number : 0
Block Device : /dev/fssnap/0
Raw Device : /dev/rfssnap/0
Mount point : /usr
Device state : idle
Backing store path : /var/tmp/back.store
Backing store size : 576 KB
Maximum backing store size : Unlimited
Snapshot create time : Wed Dec 12 09:39:37 2001
Copy-on-write granularity : 32 KB
```

### 3. Back up the UFS snapshot.

```
ufsdump 0ucf /dev/rmt/0 /snapshot-name
```

For example:

```
ufsdump 0ucf /dev/rmt/0 /dev/rfssnap/1
```

### 4. Verify that the snapshot is backed up.

```
ufsrestore tf /dev/rmt/0
```

## ▼ How to Create an Incremental Backup of a UFS Snapshot (`ufsdump`)

If you want to back up a UFS snapshot incrementally, which means only the files that have been modified since the last snapshot are backed up, use the `ufsdump` command with the `new N` option. This option specifies the file system device name to be inserted into the `/etc/dumpdates` file for tracking incremental dumps.

The following `ufsdump` command specifies an embedded `fssnap` command to create an incremental backup of a file system.

#### 1. Become superuser or assume an equivalent role.

#### 2. Create an incremental backup of a UFS snapshot.

For example:

```
ufsdump 1ufN /dev/rmt/0 /dev/rdisk/c0t1d0s0 `fssnap -F ufs -o raw,bs=
/export/scratch,unlink /dev/rdisk/c0t1d0s0`
```

The `-o raw` option is used in the example to display the name of the raw device instead of the block device. By using this option, you make it easier to embed the `fssnap` command in commands that require the raw device instead, such as the `ufsdump` command.

3. Verify that the snapshot is backed up.

```
ufsrestore ta /dev/rmt/0
```

## ▼ How to Back Up a UFS Snapshot (`tar`)

If you are using the `tar` command to back up the snapshot, mount the snapshot before backing it up.

1. Become superuser or assume an equivalent role.

2. Create a mount point for the snapshot.

For example:

```
mkdir /backups/home.bkup
```

3. Mount the snapshot.

```
mount -F ufs -o ro /dev/fssnap/1 /backups/home.bkup
```

4. Change to the mounted snapshot directory.

```
cd /backups/home.bkup
```

5. Back up the snapshot with the `tar` command.

```
tar cvf /dev/rmt/0 .
```

## Restoring Data From a UFS Snapshot Backup

The backup created from the virtual device is essentially just a backup of what the original file system looked like when the snapshot was taken. When you restore from the backup, restore as if you had taken the backup directly from the original file system, such as a backup that used the `ufsrestore` command. For information on using the `ufsrestore` command to restore a file or file system, see Chapter 49.



## Restoring Files and File Systems (Tasks)

---

This chapter describes how to use the `ufsrestore` command to restore files and file systems that were backed up by using the `ufsdump` command.

For information on the procedures associated with restoring files and file systems, see “Restoring Files and File System Backups (Task Map)” on page 689.

For information about other commands you can use to archive, restore, copy, or move files and file systems, see Chapter 51.

---

## Restoring Files and File System Backups (Task Map)

The following task map describes the procedures associated with restoring files and file systems.

| Task                                      | Description                                                                                                                    | Instructions                                              |
|-------------------------------------------|--------------------------------------------------------------------------------------------------------------------------------|-----------------------------------------------------------|
| Prepare to restore files and file systems | Identify the file system or files to be restored, the tape device, and how you will restore the files.                         | “Preparing to Restore Files and File Systems” on page 690 |
| Determine which tapes to use              | Refer to your backup tapes to find the date of the last backup that contains the file or file system that you need to restore. | “How to Determine Which Tapes to Use” on page 692         |
| Restore files                             | Choose one of the following restore methods:                                                                                   |                                                           |

| Task                                      | Description                                                                                                                                                                                                                                                                                                                                                                                                                             | Instructions                                                                                                                                                                            |
|-------------------------------------------|-----------------------------------------------------------------------------------------------------------------------------------------------------------------------------------------------------------------------------------------------------------------------------------------------------------------------------------------------------------------------------------------------------------------------------------------|-----------------------------------------------------------------------------------------------------------------------------------------------------------------------------------------|
|                                           | <p>Restore files interactively - Use this method when you are unsure of the file names because you can browse the media contents and select individual files and directories.</p> <p>Restore files non-interactively - Using this method is probably faster if you already know the few file names to be restored.</p> <p>Restore a file system - Use this method when you get a new disk drive or as part of a recovery procedure.</p> | <p>"How to Restore Files Interactively" on page 693</p> <p>"How to Restore Specific Files Non-Interactively" on page 695</p> <p>"How to Restore a Complete File System" on page 697</p> |
| Restore the root (/) or /usr file systems | Restoring the root (/) or /usr file systems involves booting the system from a local CD or the network.                                                                                                                                                                                                                                                                                                                                 | "How to Restore the root (/) and /usr File Systems" on page 700                                                                                                                         |

---

## Preparing to Restore Files and File Systems

The `ufsrestore` command copies files to disk, relative to the current working directory, from backups that were created by using the `ufsdump` command. You can use the `ufsrestore` command to reload an entire file system hierarchy from a level 0 dump and incremental dumps that follow it or to restore one or more single files from any backup tape. If the `ufsrestore` command is run as superuser, files are restored with their original owner, last modification time, and mode (permissions).

Before you start to restore files or file systems, you need to know the following:

- The tapes (or diskettes) you need
- The raw device name on which you want to restore the file system
- The type of tape device you will use
- The device name (local or remote) for the tape drive

### Determining the File System Name

If you have properly labeled your backup tapes, you should be able to use the file system name (`/dev/rdisk/device-name`) from the tape label. For more information, see "How to Find File System Names" on page 672.

## Determining the Type of Tape Device You Need

You must use a tape device that is compatible with the backup media to restore the files. The format of the backup media determines which drive you must use to restore files. For example, if your backup media is 8-mm tape, you must use an 8-mm tape drive to restore the files.

## Determining the Tape Device Name

You might have specified the tape device name (`/dev/rmt/n`) as part of the backup tape label information. If you are using the same drive to restore a backup tape, you can use the device name from the label. For more information on media devices and device names, see Chapter 52.

---

# Restoring Files and File Systems

When you back up files and directories, you save them relative to the file system in which they belong. When you restore files and directories, the `ufsrestore` command re-creates the file hierarchy in the current working directory.

For example, files backed up from the `/export/doc/books` directory (where `/export` is the file system), are saved relative to `/export`. In other words, the `book1` file in the `books` directory is saved as `./doc/books/book1` on the tape. Later on, if you restored the `./doc/books/book1` file to the `/var/tmp` directory, the file would be restored to `/var/tmp/doc/books/book1`.

When you restore individual files and directories, it is a good idea to restore them to a temporary location, such as the `/var/tmp` directory. After you verify them, you can move the files to their proper locations. You can restore individual files and directories to their original locations. If you do so, be sure you are not overwriting newer files with older versions from the backup tape.

To avoid conflicts with other users, you might want to create and change to a subdirectory, such as the `/var/tmp/restore` file, in which to restore the files.

If you are restoring a hierarchy, you should restore the files in a temporary directory on the same file system where the files will reside. So, you can use the `mv` command to move the entire hierarchy where it belongs after it is restored.

---

**Note** – Do not restore files in the `/tmp` directory even temporarily. The `/tmp` directory is usually mounted as a TMPFS file system and TMPFS does not support UFS file system attributes such as ACLs.

---

## ▼ How to Determine Which Tapes to Use

1. Ask the user for the approximate date the files to be restored were last modified.
2. Refer to your backup plan to find the date of the last backup that contains the file or file system.

To retrieve the most recent version of a file, work backward through the incremental backups from highest to lowest level and most recent to least recent, unless the user requests otherwise.

3. (Optional) If you have online archive files, identify the correct media.

```
ufsrestore ta archive-name ./path/filename ./path/filename
```

|                        |                                                                                                                                                                                                                                        |
|------------------------|----------------------------------------------------------------------------------------------------------------------------------------------------------------------------------------------------------------------------------------|
| t                      | Lists each file on the tape.                                                                                                                                                                                                           |
| a                      | Reads the table of contents from the online archive file instead of the tape.                                                                                                                                                          |
| <i>archive-name</i>    | Identifies the online archive file name.                                                                                                                                                                                               |
| <i>./path/filename</i> | Identifies the file name(s) you are looking for on the online archive. If successful, the <code>ufsrestore</code> command prints out the inode number and file name. If unsuccessful, <code>ufsrestore</code> prints an error message. |

For more information, see `ufsrestore(1M)`.

4. Insert the media that contains the files to be restored in the drive and verify the correct media.

```
ufsrestore tf /dev/rmt/n ./path/filename ./path/filename
```

Be sure to use the complete path for the *filename(s)*. If a file is in the backup, its name and inode number is listed. Otherwise, a message says that the file is not on the volume.

5. (Optional) If you have multiple dump files on the same tape, position the tape at the dump file you want to use.

```
ufsrestore tfs /dev/rmt/n tape-number
```

## Examples—Determining Which Tapes to Use

The following example shows how to check if `/etc/passwd` file is in the online archive.

```
ufsrestore ta /var/tmp/root.archive ./etc/passwd
```

The following example shows how to verify that the `/etc/passwd` is on the backup tape.

```
ufsrestore tf /dev/rmt/0 ./etc/passwd
```

## ▼ How to Restore Files Interactively

1. **Become superuser or assume an equivalent role.**
2. **(Optional) Write-protect the tapes for safety.**
3. **Insert the volume 1 tape into the tape drive.**
4. **Change to a directory that will be used to restore the files temporarily.**

```
cd /var/tmp
```

5. **Start the interactive restoration.**

```
ufsrestore if /dev/rmt/n
```

Some informational messages and the `ufsrestore>` prompt are displayed.

6. **Create a list of files to be restored.**

- a. **List the contents of a directory.**

```
ufsrestore> ls directory
```

- b. **Change to a directory.**

```
ufsrestore> cd directory-name
```

- c. **Create a list of files and directories that you want to restore.**

```
ufsrestore> add filename filename
```

- d. **(Optional) (Optional) Remove any directory or file name from the list of files to be restored, if necessary.**

```
ufsrestore> delete filename
```

7. **(Optional) (Optional) Display the file names as they are being restored.**

```
ufsrestore> verbose
```

8. **Restore the files.**

```
ufsrestore> extract
```

The `ufsrestore` command asks you which volume number to use.

9. **Type the volume number and press Return. If you have only one volume, type 1 and press Return.**

```
Specify next volume #: 1
```

The files and directories in the list are extracted and restored to the current working directory.

10. **To keep the mode of the current directory unchanged, enter `n` at the `set owner/mode` prompt.**

```
set owner/mode for `.'? [yn] n
```

You must wait while the `ufsrestore` command performs its final cleanup.

11. **Quit the `ufsrestore` program.**

```
ufsrestore> quit
```

You then see the shell prompt.

12. **Verify the restored files.**

- a. **List the restored files and directories.**

```
ls -l
```

A list of files and directories is displayed.

- b. **Check the list to be sure all the files and directories you specified in the list have been restored.**

13. **Move the files to the proper directories.**

## Example—Restoring Files Interactively

The following example shows how to extract the `/etc/passwd` and `/etc/shadow` files from the backup tape.

```
cd /var/tmp
ufsrestore if /dev/rmt/0
ufsrestore> ls
.:
.cpr_config etc/ lost+found/ sbin/ usr/
TT_DB/ export/ mnt/ sccs/ var/
b/ home/ net/ share/ vol/
bin kernel/ opt/ shared/ ws/
dev/ lib platform/ src/ xfn/
devices/ license/ proc/ tmp/
ufsrestore> cd etc
ufsrestore> add passwd shadow
ufsrestore> verbose
verbose mode on
```

```

ufsrestore> extract
Extract requested files
You have not read any volumes yet.
Unless you know which volume your file(s) are on you should start
with the last volume and work towards the first.
Specify next volume #: 1
extract file ./etc/shadow
extract file ./etc/passwd
Add links
Set directory mode, owner, and times.
set owner/mode for `.'? [yn] n
ufsrestore> quit
#

```

## ▼ How to Restore Specific Files Non-Interactively

1. **Become superuser or assume an equivalent role.**
2. **(Optional) Write-protect the tape for safety.**
3. **Insert the volume 1 tape into the tape drive.**
4. **Change to a directory that will be used to restore files temporarily.**

```
cd /var/tmp
```

5. **Restore the file or files.**

```
ufsrestore xvf /dev/rmt/n filename
```

|                                  |                                                                                                                                                           |
|----------------------------------|-----------------------------------------------------------------------------------------------------------------------------------------------------------|
| <code>x</code>                   | Tells <code>ufsrestore</code> to copy specific files or directories in the <i>filename</i> argument.                                                      |
| <code>v</code>                   | Displays the file names as they are restored.                                                                                                             |
| <code>f /dev/rmt/<i>n</i></code> | Identifies the tape device name.                                                                                                                          |
| <code><i>filename</i></code>     | Specifies one or more individual file names or directory names separated by spaces, for example:<br>./export/home/user1/mail<br>./export/home/user2/mail. |

6. **Type the volume number where files are located and press Return.**

```
Specify next volume #: 1
```

The file or files are restored to the current working directory.

7. **To keep the mode of the current directory unchanged, type `n` and press Return at the `set owner/mode` prompt.**

```
set owner/mode for `.'? [yn] n
```

**8. Verify the restored files.**

**a. List the restored files and directories.**

```
ls -l
```

A list of files and directories is displayed.

**b. Check the list to be sure all the files and directories you specified in the list have been restored.**

**9. Move the files to the proper directories.**

## Example—Restoring Specific Files Non-Interactively

The following example shows how to restore the `passwd` and `shadow` files to the `/var/tmp` directory.

```
cd /var/tmp
ufsrestore xvf /dev/rmt/0 ./etc/passwd ./etc/shadow
Verify volume and initialize maps
Media block size is 126
Dump date: Wed Dec 12 10:54:45 2001
Dumped from: the epoch
Level 0 dump of / on earth:/dev/dsk/c0t1d0s0
Label: none
Extract directories from tape
Initialize symbol table.
Make node ./etc
Extract requested files
You have not read any volumes yet.
Unless you know which volume your file(s) are on you should start
with the last volume and work towards the first.
Specify next volume #: 1
extract file ./etc/passwd
extract file ./etc/shadow
Add links
Set directory mode, owner, and times.
set owner/mode for `.'? [yn] n
cd etc
mv passwd /etc
mv shadow /etc
ls -l /etc
```

## Example—Restoring Files From a Remote Tape Device

You can restore files from a remote tape drive by adding `remote-host :` to the front of the tape device name, when using the `ufsrestore` command.

The following example shows how to restore files using a remote tape drive `/dev/rmt/0` on the system `venus`.



```
ufsrestore xf venus:/dev/rmt/0 ./etc/hosts
```

## ▼ How to Restore a Complete File System

Occasionally, a file system becomes so damaged that you must completely restore it. Typically, you need to restore a complete file system after a disk failure. You might need to replace the hardware before you can restore the software. For information on how to replace a disk, see Chapter 34 or Chapter 35. Full restoration of a file system such as `/export/home` can take a lot of time. If you have consistently backed up file systems, you can restore them to their state from the time of the last incremental backup.

---

**Note** – You cannot use this procedure to restore the root (`/`) or `/usr` file systems. For instructions on restoring these file systems, see “How to Restore the root (`/`) and `/usr` File Systems” on page 700.

---

1. **Become superuser or assume an equivalent role.**

2. **If necessary, unmount the file system.**

```
umount /dev/rdisk/device-name
```

3. **Create the new file system.**

```
newfs /dev/rdisk/device-name
```

You are asked if you want to construct a new file system on the raw device. Verify that the *device-name* is correct so you don't destroy the wrong file system.

For more information, see `newfs(1M)`.

4. **Confirm that the new file system should be created.**

```
newfs: construct a new file system /dev/rdisk/cwtxdysz: (y/n)? y
```

The new file system is created.

5. **Mount the new file system on a temporary mount point.**

```
mount /dev/dsk/device-name /mnt
```

6. **Change to the mount point directory.**

```
cd /mnt
```

7. **(Optional) Write-protect the tapes for safety.**

8. **Insert the first volume of the level 0 tape into the tape drive.**

9. **Restore the files.**

```
ufsrestore rvf /dev/rmt/n
```

The level 0 dump is restored. If the dump required multiple tapes, you are prompted to load each tape in numeric order.

**10. Remove the tape and load the next level tape in the drive.**

Always restore tapes starting with 0 and continuing until you reach the highest level.

**11. Repeat Step 8 through Step 10 for each dump level, from the lowest to the highest level.**

**12. Verify that the file system is restored.**

```
ls
```

**13. Remove the `restoresymtable` file.**

```
rm restoresymtable
```

The `restoresymtable` file that is created and used by the `ufsrestore` command to check-point the restore is removed.

**14. Change to another directory.**

```
cd /
```

**15. Unmount the newly restored file system.**

```
umount /mnt
```

**16. Remove the last tape and insert a new tape that is not write-protected in the tape drive.**

**17. Make a level 0 backup of the newly restored file system.**

```
ufsdump 0uf /dev/rmt/n /dev/rdsk/device-name
```

A level 0 backup is performed. Always do an immediate backup of a newly created file system because `ufsrestore` repositions the files and changes the inode allocation.

**18. Mount the restored file system.**

```
mount /dev/dsk/device-name mount-point
```

The restored file system is mounted and available for use.

**19. Verify that the restored and mounted file system is available.**

```
ls mount-point
```

## Example—Restoring a Complete File System

The following example shows how to restore the `/export/home` file system.

```

umount /export/home
newfs /dev/rdisk/c0t3d0s7
newfs: construct a new file system /dev/rdisk/c0t3d0s7: (y/n)? y
/dev/rdisk/c0t3d0s7: 410400 sectors in 270 cylinders of 19 tracks,
80 sectors
200.4MB in 17 cyl groups (16 c/g, 11.88MB/g, 5696 i/g)
super-block backups (for fsck -F ufs -o b=#) at:
 32, 24432, 48832, 73232, 97632, 122032, 146432, 170832, 195232, 219632,
244032, 268432, 292832, 317232, 341632, 366032, 390432,
mount /dev/dsk/c0t3d0s7 /mnt
cd /mnt
ufsrestore rvf /dev/rmt/0
Verify volume and initialize maps
Media block size is 126
Dump date: Sat Jul 14 08:49:33 2001
Dumped from: the epoch
Level 0 dump of /export/home on earth:/dev/dsk/c0t3d0s7
Label: none
Begin level 0 restore
Initialize symbol table.
Extract directories from tape
Calculate extraction list.
Warning: ./lost+found: File exists
Make node ./kryten
Make node ./kryten/letters
Make node ./kryten/reports
Extract new leaves.
Check pointing the restore
extract file ./kryten/.cshrc
extract file ./kryten/.login
extract file ./kryten/b
extract file ./kryten/memos
extract file ./kryten/letters/b
extract file ./kryten/letters/letter1
extract file ./kryten/letters/letter2
extract file ./kryten/letters/letter3
extract file ./kryten/reports/reportA
extract file ./kryten/reports/reportB
extract file ./kryten/reports/reportC
Add links
Set directory mode, owner, and times.
Check the symbol table.
Check pointing the restore
ls
rm restoresymtable
cd /
umount /mnt
ufsdump 0ucf /dev/rmt/0 /export/home
.
.
.
mount /dev/dsk/c0t3d0s7 /export/home
ls /export/home

```

## ▼ How to Restore the root (/) and /usr File Systems

1. **Become superuser or assume an equivalent role.**
2. **Add a new system disk to the system where the root (/) and /usr file systems will be restored.**

For a detailed description about adding a system disk, refer to Chapter 34 or Chapter 35.
3. **Mount the new file system on a temporary mount point.**

```
mount /dev/dsk/device-name /mnt
```
4. **Change to the /mnt directory.**

```
cd /mnt
```
5. **(Optional) Write-protect the tapes for safety.**
6. **Restore the root file system.**

```
ufsrestore rvf /dev/rmt/n
```

The level 0 tape is restored.
7. **Remove the tape and load the next level tape in the drive.**

Always restore tapes starting with dump level 0 and continuing from lowest to highest level.
8. **Continue restoring as needed.**

```
ufsrestore rvf /dev/rmt/n
```

The next level tape is restored.
9. **Repeat Step 7 and Step 8 for each additional tape.**
10. **Verify the file system is restored.**

```
ls
```
11. **Remove the `restoresymtable` file.**

```
rm restoresymtable
```

The `restoresymtable` file that is created and used by the `ufsrestore` command to check-point the restore is removed.
12. **Change to the root (/) directory.**

```
cd /
```
13. **Unmount the newly created file system.**

```
umount /mnt
```

#### 14. Check the new file system.

```
fsck /dev/rdisk/device-name
```

The restored file system is checked for consistency.

#### 15. Create the boot blocks on the root partition.

```
installboot /usr/platform/`uname-i`/lib/fs/ufs/bootblk
/dev/rdisk/device-name
```

For more information, see `installboot(1M)`.

For an example of using the `installboot` command on a SPARC based system, see “SPARC: Example—Restoring the root (/) File System” on page 701. For an example of using the `installboot` command on an x86 based system, see “x86: Example—Restoring the root (/) File System” on page 702.

#### 16. Insert a new tape in the tape drive.

#### 17. Back up the new file system.

```
ufsdump 0uf /dev/rmt/n /dev/rdisk/device-name
```

A level 0 backup is performed. Always do an immediate backup of a newly created file system because `ufsrestore` repositions the files and changes the inode allocation.

#### 18. Repeat steps 5 through 16 for the /usr file system, if necessary.

#### 19. Reboot the system.

```
init 6
```

The system is rebooted.

## SPARC: Example—Restoring the root (/) File System

This example shows how to restore the root (/) file system on a SPARC system. This example assumes that the system is booted from a local CD or from the network.

```
mount /dev/dsk/c0t3d0s0 /mnt
cd /mnt
tapes
ufsrestore rvf /dev/rmt/0
ls
rm restoresymtable
cd /
umount /mnt
fsck /dev/rdisk/c0t3d0s0
installboot /usr/platform/sun4u/lib/fs/ufs/bootblk /dev/rdisk/c0t3d0s0
ufsdump 0uf /dev/rmt/0 /dev/rdisk/c0t3d0s0
init 6
```

## x86: Example—Restoring the root (/) File System

This example shows how to restore the root (/) file system on an x86 system. This example assumes that the system is booted from a local CD or from the network.

```
mount /dev/dsk/c0t3d0s0 /mnt
cd /mnt
tapes
ufsrestore rvf /dev/rmt/0
ls
rm restoresymtable
cd /
umount /mnt
fsck /dev/rdisk/c0t3d0s0
installboot /usr/platform/`uname -i`/lib/fs/ufs/pboot /usr/platform/`uname -i`/lib/fs/
ufs/bootblk /dev/rdisk/c0t3d0s2
ufsdump 0uf /dev/rmt/0 /dev/rdisk/c0t3d0s0
init 6
```

## UFS Backup and Restore Commands (Reference)

---

This chapter contains reference information on the `ufsdump` and `ufsrestore` commands.

This is a list of information in this chapter.

- “How the `ufsdump` Command Works” on page 703
- “Options and Arguments for the `ufsdump` Command” on page 708
- “The `ufsdump` Command and Security Issues” on page 710
- “Options and Arguments for the `ufsrestore` Command” on page 711

---

### How the `ufsdump` Command Works

The `ufsdump` command makes two passes when it backs up a file system. On the first pass, this command scans the raw device file for the file system and builds a table of directories and files in memory. Then, this command writes the table to the backup media. In the second pass, the `ufsdump` command goes through the inodes in numerical order, reading the file contents and writing the data to the media.

### Determining Device Characteristics

The `ufsdump` command needs to know only an appropriate block size and how to detect the end of media.

## Detecting the End of Media

The `ufsdump` command writes a sequence of fixed-size records. When the `ufsdump` command receives notification that a record was only partially written, it assumes that it has reached the physical end of the media. This method works for most devices. If a device is not able to notify the `ufsdump` command that only a partial record has been written, a media error occurs as the `ufsdump` command tries to write another record.

---

**Note** – DAT devices and 8-mm tape devices detect end-of-media. Cartridge tape devices and 1/2-inch tape devices do not detect end-of-media.

---

The `ufsdump` command automatically detects the end-of-media for most devices. Therefore, you do not usually need to use the `-c`, `-d`, `-s`, and `-t` options to perform multivolume backups.

The only time you need to use the end-of-media options is when the `ufsdump` command does not understand the way the device detects the end-of-media or you are going to restore the files on a SunOS 4.1 system with an the `restore` command. To ensure compatibility with the `restore` command, the `size` option can still force the `ufsdump` command to go to the next tape or diskette before reaching the end of the current tape or diskette.

## Copying Data With `ufsdump`

The `ufsdump` command copies data only from the raw disk slice. If the file system is still active, anything in memory buffers is probably not copied. The backup done by `ufsdump` does not copy free blocks, nor does it make an image of the disk slice. If symbolic links point to files on other slices, the link itself is copied.

## Role of the `/etc/dumpdates` File

The `ufsdump` command, when used with the `-u` option, maintains and updates the `/etc/dumpdates` file. Each line in the `/etc/dumpdates` file shows the file system backed up, the level of the last backup, and the day, date, and time of the backup. For example:

```
/dev/rdsk/c0t0d0s7 0 Mon Dec 10 16:26:10 2001
/dev/rdsk/c0t0d0s7 9 Tue Dec 11 16:45:14 2001
/dev/rdsk/c0t0d0s7 9 Wed Dec 12 16:54:47 2001
```



When you do an incremental backup, the `ufsdump` command checks the `/etc/dumpdates` file to find the date of the most recent backup of the next lower level. Then, this command copies to the media all files that were modified since the date of that lower-level backup. After the backup is complete, a new information line, which describes the backup you just completed, replaces the information line for the previous backup at that level.

Use the `/etc/dumpdates` file to verify that backups are being done. This verification is particularly important if you are having equipment problems. If a backup cannot be completed because of equipment failure, the backup is not recorded in the `/etc/dumpdates` file.

If you need to restore an entire disk, check the `/etc/dumpdates` file for a list of the most recent dates and levels of backups so that you can determine which tapes you need in order to restore the entire file system.

---

**Note** – The `/etc/dumpdates` file is a text file that can be edited, but edit it only at your own risk. If you make changes to the file that do not match your archive tapes, you might not be able to find the tapes (or files) you need.

---

## Backup Device (*dump-file*) Argument

The *dump-file* argument (to the `-f` option) specifies the destination of the backup, which can be one of the following:

- Local tape drive or diskette drive
- Remote tape drive or diskette drive
- Standard output

Use this argument when the destination is not the default local tape drive `/dev/rmt/0`. If you use the `-f` option, then you must specify a value for *dump-file*.

---

**Note** – The *dump-file* argument can also point to a file on a local or remote disk, which, if used by mistake, can fill up a file system.

---

## Local Tape or Diskette Drive

Typically, the *dump-file* argument specifies a raw device file for a tape device or diskette. When the `ufsdump` command writes to an output device, it creates a single backup file that might span multiple tapes or diskettes.

You specify a tape device or diskette on your system by using a device abbreviation. The first device is always 0. For example, if you have a SCSI tape controller and one QIC-24 tape drive that uses medium-density formatting, use this device name:

```
/dev/rmt/0m
```

When you specify a tape device name, you can also type the letter “n” at the end of the name to indicate that the tape drive should not rewind after the backup is completed. For example:

```
/dev/rmt/0mn
```

Use the “no-rewind” option if you want to put more than one file onto the tape. If you run out of space during a backup, the tape does not rewind before the `ufsdump` command asks for a new tape. For a complete description of device naming conventions, see “Backup Device Names” on page 740.

## Remote Tape or Diskette Drive

You specify a remote tape device or diskette by using the syntax *host:device*. The `ufsdump` command writes to the remote device when root on the local system has access to the remote system. If you usually run the `ufsdump` command as root, the name of the local system must be included in the `.rhosts` file on the remote system. If you specify the device as *user@host:device*, the `ufsdump` command tries to access the device on the remote system as the specified user. In this case, the specified user must be included in the `.rhosts` file on the remote system.

Use the naming convention for the device that matches the operating system for the system on which the device resides, not the system from which you run the `ufsdump` command. If the drive is on a system that is running a previous SunOS release (for example, 4.1.1), use the SunOS 4.1 device name (for example, `/dev/rst0`). If the system is running Solaris software, use the SunOS 5.9 convention (for example, `/dev/rmt/0`).

## Using Standard Output With the `ufsdump` Command

When you specify a dash (-) as the *dump-file* argument, the `ufsdump` command writes to standard output.

---

**Note** – The `-v` option (verify) does not work when the *dump-file* argument is standard output.

---

You can use the `ufsdump` and `ufsrestore` commands in a pipeline to copy a file system by writing to the standard output with the `ufsdump` command and reading from standard input with the `ufsrestore` command, as shown in this example:

```
ufsdump 0f - /dev/rdisk/c0t0d0s7 | (cd /home; ufsrestore xf -)
```

## Specifying Files to Back Up

You must always include *filenames* as the last argument on the command line. This argument specifies the source or contents of the backup.

For a file system, specify the raw device file as follows:

```
/dev/rdisk/c0t0d0s6
```

You can specify the file system by its mount point directory (for example, */export/home*), as long as there is an entry for it in the */etc/vfstab* file.

For a complete description of device naming conventions, see “Backup Device Names” on page 740.

For individual files or directories, type one or more names separated by spaces.

---

**Note** – When you use the `ufsdump` command to back up one or more directories or files (rather than a complete file system), a level 0 backup is done. Incremental backups do not apply.

---

## Specifying Tape Characteristics

If you do not specify any tape characteristics, the `ufsdump` command uses a set of defaults. You can specify tape cartridge (*c*), density (*d*), size (*s*), and number of tracks (*t*). Note that you can specify the options in any order as long as the arguments that follow match the order of the options.

## Limitations of the `ufsdump` Command

The `ufsdump` command cannot do the following:

- Automatically calculate the number of tapes or diskettes that are needed for backing up file systems. You can use the dry run mode (*S* option) to determine the amount of space that is needed before actually backing up file systems.
- Provide built-in error checking to minimize problems when it backs up an active file system.
- Back up files that are remotely mounted from a server. Files on the server must be backed up on the server itself. Users are denied permission to run the `ufsdump` command on files they own that are located on a server.

---

## Options and Arguments for the `ufsdump` Command

This section describes in detail the options and arguments for the `ufsdump` command. The syntax for the `ufsdump` command is as follows:

```
/usr/sbin/ufsdump options arguments filenames
```

|                  |                                                                                                                                              |
|------------------|----------------------------------------------------------------------------------------------------------------------------------------------|
| <i>options</i>   | Is a single string of one-letter option names.                                                                                               |
| <i>arguments</i> | Identifies option arguments and might be multiple strings. The option letters and the arguments that go with them must be in the same order. |
| <i>filenames</i> | Identifies the files to back up. These arguments must always come last.                                                                      |

### Default `ufsdump` Options

If you run the `ufsdump` command without any options, use this syntax:

```
ufsdump filenames
```

The `ufsdump` command uses these options and arguments, by default:

```
ufsdump 9uf /dev/rmt/0 filenames
```

These options do a level 9 incremental backup to the default tape drive at its preferred density.

### Options for the `ufsdump` Command

The following table describes the options for the `ufsdump` command.

**TABLE 50-1** Options for the `ufsdump` Command

| Option | Description                                                                                                                                                                                                       |
|--------|-------------------------------------------------------------------------------------------------------------------------------------------------------------------------------------------------------------------|
| 0-9    | Dump level. Level 0 is for a full backup of the complete file system that is specified by <i>filenames</i> . Levels 1-9 are for incremental backups of files that have changed since the last lower-level backup. |

**TABLE 50–1** Options for the `ufsdump` Command (Continued)

| Option                | Description                                                                                                                                                                                                                                                                                                                                                                                                                                                  |
|-----------------------|--------------------------------------------------------------------------------------------------------------------------------------------------------------------------------------------------------------------------------------------------------------------------------------------------------------------------------------------------------------------------------------------------------------------------------------------------------------|
| <i>a archive-file</i> | Archive file. Stores (archives) a backup table of contents in a specified file on the disk. The file can be understood only by the <code>ufsrestore</code> command, which uses it to determine whether a file to be restored is present in a backup file, and if so, on which volume of the media it resides.                                                                                                                                                |
| <i>b factor</i>       | Blocking factor. Specifies the number of 512-byte blocks to write to tape at a time.                                                                                                                                                                                                                                                                                                                                                                         |
| <i>c</i>              | Cartridge. Back up to cartridge tape. When end-of-media detection applies, this option sets the block size to 126.                                                                                                                                                                                                                                                                                                                                           |
| <i>d bpi</i>          | Tape density. Use this option only when the <code>ufsdump</code> command cannot detect the end of the media.                                                                                                                                                                                                                                                                                                                                                 |
| <i>D</i>              | Diskette. Backs up to diskette.                                                                                                                                                                                                                                                                                                                                                                                                                              |
| <i>f dump-file</i>    | Dump file. Writes the files to the destination that is specified by <i>dump-file</i> instead of the default device. If the file is specified as <i>user@system:device</i> , the <code>ufsdump</code> command attempts to execute as the specified user on the remote system. The specified user must have a <code>.rhosts</code> file on the remote system that allows the user who is invoking the command on the local system to access the remote system. |
| <i>l</i>              | Autoload. Use this option if you have an autoloading (stackloader) tape drive. When the end of a tape is reached, this option takes the drive offline and waits up to two minutes for the tape drive to be ready again. If the drive is ready within two minutes, it continues. If the drive is not ready after two minutes, it prompts the operator to load another tape.                                                                                   |
| <i>n</i>              | Notify. When intervention is needed, this option sends a message to all terminals of all users in the <code>sys</code> group.                                                                                                                                                                                                                                                                                                                                |
| <i>o</i>              | Offline. When finished with a tape or diskette, this option takes the drive offline, rewinds (if tape), and if possible removes the media (for example, ejects a diskette or removes an 8-mm autoloaded tape).                                                                                                                                                                                                                                               |
| <i>s size</i>         | Size. Specifies the length of tapes in feet or for diskettes, the number of 1024-byte blocks. Use this option only when the <code>ufsdump</code> command cannot detect the end of the media.                                                                                                                                                                                                                                                                 |
| <i>S</i>              | Estimates the size of the backup. Determines the amount of space that is needed to perform the backup, without actually doing it, and outputs a single number that indicates the estimated size of the backup in bytes.                                                                                                                                                                                                                                      |

**TABLE 50-1** Options for the `ufsdump` Command (Continued)

| Option                | Description                                                                                                                                                                                                                                                                                                                                                                                                                      |
|-----------------------|----------------------------------------------------------------------------------------------------------------------------------------------------------------------------------------------------------------------------------------------------------------------------------------------------------------------------------------------------------------------------------------------------------------------------------|
| <code>t tracks</code> | Tracks. Specifies the number of tracks for a 1/4-inch cartridge tape. Use this option only when the <code>ufsdump</code> command cannot detect the end of the media.                                                                                                                                                                                                                                                             |
| <code>u</code>        | Updates the dump record. A completed backup of a file system adds an entry to the <code>/etc/dumpdates</code> file. The entry indicates the device name for the file system's disk slice, the dump level (0-9), and the date. No record is written when you do not use the <code>u</code> option or when you back up individual files or directories. If a record already exists for a backup at the same level, it is replaced. |
| <code>v</code>        | Verify. After each tape or diskette is written, verifies the contents of the media against the source file system. If any discrepancies occur, prompts the operator to mount new media, then repeats the process. Use this option only on an unmounted file system, because any activity in the file system causes the <code>ufsdump</code> command to report discrepancies.                                                     |
| <code>w</code>        | Warning. Lists the file systems that appear in the <code>/etc/dumpdates</code> file that have not been backed up within a day. When you use this option, all other options are ignored.                                                                                                                                                                                                                                          |
| <code>W</code>        | Warning with highlight. Shows all the file systems that appear in the <code>/etc/dumpdates</code> file and highlights those file systems that have not been backed up within a day. When you use this option, all other options are ignored.                                                                                                                                                                                     |

---

**Note** – The `/etc/vfstab` file does not contain information about how often to back up a file system.

---

---

## The `ufsdump` Command and Security Issues

If you are concerned about security, you should do the following:

- Require root access for the `ufsdump` command.
- Ensure root access entries are removed from `.rhosts` files on clients and servers if doing centralized backups.

For general information on security, see *System Administration Guide: Security Services*.

---

# Options and Arguments for the `ufsrestore` Command

The syntax of the `ufsrestore` command is:

```
ufsrestore options arguments filenames
```

|                  |                                                                                                                                                                                                                                                     |
|------------------|-----------------------------------------------------------------------------------------------------------------------------------------------------------------------------------------------------------------------------------------------------|
| <i>options</i>   | Is a single string of one-letter option names. You must choose one and only one of these options: <code>i</code> , <code>r</code> , <code>R</code> , <code>t</code> , or <code>x</code> . The additional options listed in Table 50–3 are optional. |
| <i>arguments</i> | Follows the option string with the arguments that match the options. The option letters and the arguments that go with them must be in the same order.                                                                                              |
| <i>filenames</i> | Specifies the files to be restored as arguments to the <code>x</code> or <code>t</code> options. These arguments must always come last.                                                                                                             |

You must use one (and only one) of the `ufsrestore` command options shown in the following table.

**TABLE 50–2** One Required Option for the `ufsrestore` Command

| Option         | Description                                                                                                                                                                                                                                                                                                                                                                                                                                                                                                                                                                     |
|----------------|---------------------------------------------------------------------------------------------------------------------------------------------------------------------------------------------------------------------------------------------------------------------------------------------------------------------------------------------------------------------------------------------------------------------------------------------------------------------------------------------------------------------------------------------------------------------------------|
| <code>i</code> | Interactive. Runs the <code>ufsrestore</code> command in an interactive mode. In this mode, you can use a limited set of shell-like commands to browse the contents of the media and select individual files or directories to restore. For a list of interactive commands, see Table 50–4.                                                                                                                                                                                                                                                                                     |
| <code>r</code> | Recursive. Restores the entire contents of the media into the current working directory (which should be the top level of the file system). Information used to restore incremental dumps on top of the full dump (for example, <code>restoresymtable</code> ) is also included. To completely restore a file system, use this option to restore the full (level 0) dump and each subsequent incremental dump. Although this option is intended for a new file system (that was just created with the <code>newfs</code> command), files not on the backup media are preserved. |
| <code>R</code> | Resume restoring. Prompts for the volume from which to resume restoring and restarts from a checkpoint. You rerun the <code>ufsrestore</code> command with this option after a full restore ( <code>r</code> option) is interrupted.                                                                                                                                                                                                                                                                                                                                            |

**TABLE 50-2** One Required Option for the `ufsrestore` Command (Continued)

| Option                     | Description                                                                                                                                                                                                                                                                                                                                                                                                                                                                                                                                                                                                                                                                                                                                                                                                                                              |
|----------------------------|----------------------------------------------------------------------------------------------------------------------------------------------------------------------------------------------------------------------------------------------------------------------------------------------------------------------------------------------------------------------------------------------------------------------------------------------------------------------------------------------------------------------------------------------------------------------------------------------------------------------------------------------------------------------------------------------------------------------------------------------------------------------------------------------------------------------------------------------------------|
| <code>x [filenames]</code> | Extract. Selectively restores the files you specify by the <i>filenames</i> argument. <i>filenames</i> can be a list of files and directories. All files under a specified directory are restored unless you also use the <code>h</code> option. If you omit <i>filenames</i> or enter <code>."</code> for the root directory, all files on all volumes of the media (or from standard input) are restored. Existing files are overwritten, and warnings are displayed.                                                                                                                                                                                                                                                                                                                                                                                  |
| <code>t [filenames]</code> | Table of contents. Checks the files that are specified in the <i>filenames</i> argument against the media. For each file, lists the full file name and the inode number (if the file is found) or indicates that the file is not on the "volume" (meaning any volume in a multivolume dump). If you do not enter the <i>filenames</i> argument, all files on all volumes of the media are listed (without distinguishing on which volume files are located). If you also use the <code>h</code> option, only the directory files that are specified in <i>filenames</i> , not their contents, are checked and listed. The table of contents is read from the first volume of the media, or, if you use the <code>a</code> option, from the specified archive file. This option is mutually exclusive with the <code>x</code> and <code>r</code> options. |

Additional `ufsrestore` options are described in the following table.

**TABLE 50-3** Additional Options for the `ufsrestore` Command

| Option                                  | Description                                                                                                                                                                                                                                                                                                                                                                                                                                                                                                                                                 |
|-----------------------------------------|-------------------------------------------------------------------------------------------------------------------------------------------------------------------------------------------------------------------------------------------------------------------------------------------------------------------------------------------------------------------------------------------------------------------------------------------------------------------------------------------------------------------------------------------------------------|
| <code>a archive-file [filenames]</code> | Takes the dump table of contents from the specified <i>archive-file</i> instead of from the media (first volume). You can use this option in combination with the <code>t</code> , <code>i</code> , or <code>x</code> options to see if files are on the media without having to mount any media. If you use it with the <code>x</code> and interactive extract options, you are prompted to mount the appropriate volume before extracting the file(s).                                                                                                    |
| <code>b factor</code>                   | Blocking factor. Specifies number of 512-byte blocks read from tape at a time. By default, the <code>ufsrestore</code> command tries to figure out the block size that was used in writing the tape.                                                                                                                                                                                                                                                                                                                                                        |
| <code>d</code>                          | Debug. Turns on debugging messages.                                                                                                                                                                                                                                                                                                                                                                                                                                                                                                                         |
| <code>f backup-file</code>              | Backup file. Reads the files from the source indicated by <i>backup-file</i> , instead of from the default device file <code>/dev/rmt/0m</code> . If you use the <code>f</code> option, you must specify a value for <i>backup-file</i> . When <i>backup-file</i> is of the form <i>system:device</i> , the <code>ufsrestore</code> command reads from the remote device. You can also use the <i>backup-file</i> argument to specify a file on a local or remote disk. If <i>backup-file</i> is <code>'-'</code> , the files are read from standard input. |



**TABLE 50-3** Additional Options for the `ufsrestore` Command (Continued)

| Option           | Description                                                                                                                                                                                                                                                                                                                                                                                                                           |
|------------------|---------------------------------------------------------------------------------------------------------------------------------------------------------------------------------------------------------------------------------------------------------------------------------------------------------------------------------------------------------------------------------------------------------------------------------------|
| <code>h</code>   | Turns off directory expansion. Only the directory file you specify is extracted or listed.                                                                                                                                                                                                                                                                                                                                            |
| <code>m</code>   | Restores specified files into the current directory on the disk regardless of where they are located in the backup hierarchy and renames them with their inode number. For example, if the current working directory is <code>/files</code> , a file in the backup named <code>./dready/fcs/test</code> with inode number 42, is restored as <code>/files/42</code> . This option is useful only when you are extracting a few files. |
| <code>s n</code> | Skips to the <i>n</i> th backup file on the media (first volume). This option is useful when you put more than one backup on a single tape.                                                                                                                                                                                                                                                                                           |
| <code>v</code>   | Verbose. Displays the names and inode numbers of each file as it is restored.                                                                                                                                                                                                                                                                                                                                                         |
| <code>y</code>   | Continues when errors occur while reading the media and tries to skip over bad blocks instead of stopping and asking whether to continue. This option tells the command to assume a yes response.                                                                                                                                                                                                                                     |

The following table describes `ufsrestore`'s interactive commands.

**TABLE 50-4** Commands for Interactive Restore

| Option                           | Description                                                                                                                                                                                                                                                                                                                                                                                                                                                |
|----------------------------------|------------------------------------------------------------------------------------------------------------------------------------------------------------------------------------------------------------------------------------------------------------------------------------------------------------------------------------------------------------------------------------------------------------------------------------------------------------|
| <code>ls [directory-name]</code> | Lists the contents of either the current directory or the specified directory. Directories are marked by a <code>/</code> suffix. Entries in the current list to be restored (extracted) are marked by an <code>*</code> prefix. Inode numbers are shown if the verbose option is used.                                                                                                                                                                    |
| <code>cd directory-name</code>   | Changes to the specified directory in the backup hierarchy.                                                                                                                                                                                                                                                                                                                                                                                                |
| <code>add [filename]</code>      | Adds the current directory or the specified file or directory to the list of files to extract (restore). If you do not use the <code>h</code> option, all files in a specified directory and its subdirectories are added to the list. All the files you want to restore to a directory might not be on a single backup tape or diskette. You might need to restore from multiple backups at different levels to get the latest versions of all the files. |

**TABLE 50-4** Commands for Interactive Restore (Continued)

| Option                         | Description                                                                                                                                                                                                                                                                                                                                                                                                                                                                                                                                                                                                                                                                   |
|--------------------------------|-------------------------------------------------------------------------------------------------------------------------------------------------------------------------------------------------------------------------------------------------------------------------------------------------------------------------------------------------------------------------------------------------------------------------------------------------------------------------------------------------------------------------------------------------------------------------------------------------------------------------------------------------------------------------------|
| <code>delete [filename]</code> | Deletes the current directory or the specified file or directory from the list of files to extract (restore). If you do not use the <code>h</code> option, all files in the specified directory and its subdirectories are deleted from the list. The files and directories are deleted only from the extract list you are building. They are not deleted from the media or the file system.                                                                                                                                                                                                                                                                                  |
| <code>extract</code>           | Extracts the files in the list and restores them relative to the current working directory on the disk. Specify <code>1</code> when you are asked for a volume number for a single-volume backup. If you are doing a multitape or multidiskette restore and restoring a small number of files, start with the last tape or diskette instead.                                                                                                                                                                                                                                                                                                                                  |
| <code>help</code>              | Displays a list of commands you can use in interactive mode.                                                                                                                                                                                                                                                                                                                                                                                                                                                                                                                                                                                                                  |
| <code>pwd</code>               | Displays the path name of the current working directory in the backup hierarchy.                                                                                                                                                                                                                                                                                                                                                                                                                                                                                                                                                                                              |
| <code>q</code>                 | Quits interactive mode without restoring any additional files.                                                                                                                                                                                                                                                                                                                                                                                                                                                                                                                                                                                                                |
| <code>setmodes</code>          | Lets you set the mode for files to be restored to match the mode of the root directory of the file system from which they were backed up. You are prompted with: <code>set owner/mode for ' . ' [yn] ?</code> Type <code>y</code> (for yes) to set the mode (permissions, owner, times) of the current directory to match the root directory of the file system from which they were backed up. Use this mode when you restore a complete file system.<br><br>Type <code>n</code> (for no) to leave the mode of the current directory unchanged. Use this mode when you restore part of a backup to a directory other than the directory from which the files were backed up. |
| <code>verbose</code>           | Turns on or off the verbose option (which can also be entered as <code>v</code> on the command line outside of interactive mode). When verbose is on, the interactive <code>ls</code> command lists inode numbers and the <code>ufsrestore</code> command displays information on each file as it is extracted.                                                                                                                                                                                                                                                                                                                                                               |
| <code>what</code>              | Displays the backup header from the tape or diskette.                                                                                                                                                                                                                                                                                                                                                                                                                                                                                                                                                                                                                         |

## Copying UFS Files and File Systems (Tasks)

---

This chapter describes how to copy UFS files and file systems to disk, tape, and diskettes by using various backup commands.

This is a list of the step-by-step instructions in this chapter.

- “How to Copy a Disk (`dd`)” on page 718
- “How to Copy Directories Between File Systems (`cpio`)” on page 720
- “How to Copy Files to a Tape (`tar`)” on page 723
- “How to List the Files on a Tape (`tar`)” on page 724
- “How to Retrieve Files From a Tape (`tar`)” on page 724
- “Copying Files to a Tape With the `pax` Command” on page 726
- “How to Copy All Files in a Directory to a Tape (`cpio`)” on page 727
- “How to List the Files on a Tape (`cpio`)” on page 728
- “How to Retrieve All Files From a Tape (`cpio`)” on page 729
- “How to Retrieve Specific Files From a Tape (`cpio`)” on page 730
- “How to Copy Files to a Remote Tape Device (`tar` and `dd`)” on page 731
- “How to Extract Files From a Remote Tape Device” on page 732
- “How to Copy Files to a Single Formatted Diskette (`tar`)” on page 734
- “How to List the Files on a Diskette (`tar`)” on page 735
- “How to Retrieve Files From a Diskette (`tar`)” on page 735
- “How to Create an Archive for Older SunOS Releases” on page 737
- “How to Retrieve `bar` Files From a Diskette” on page 737

---

## Commands for Copying File Systems

When you need to back up and restore complete file systems, use the `ufsdump` and `ufsrestore` commands described in Chapter 50. When you want to copy or move individual files, portions of file systems, or complete file systems, you can use the procedures described in this chapter instead of the `ufsdump` and `ufsrestore` commands.

The following table describes when to use the various backup commands.

**TABLE 51–1** When to Use Various Backup Commands

| <b>Task</b>                              | <b>Command</b>                                             | <b>For More Information</b>                                                         |
|------------------------------------------|------------------------------------------------------------|-------------------------------------------------------------------------------------|
| Back up file systems to tape             | <code>ufsdump</code>                                       | “How to Backup a File System to Tape” on page 674                                   |
| Create a file system snapshot            | <code>fssnap</code>                                        | Chapter 48                                                                          |
| Restore file systems from tape           | <code>ufsrestore</code>                                    | “How to Restore a Complete File System” on page 697                                 |
| Transport files to other systems         | <code>pax</code> , <code>tar</code> , or <code>cpio</code> | “Copying Files and File Systems to Tape” on page 721                                |
| Copy files or file systems between disks | <code>dd</code>                                            | “How to Copy a Disk ( <code>dd</code> )” on page 718                                |
| Copy files to diskette                   | <code>tar</code>                                           | “How to Copy Files to a Single Formatted Diskette ( <code>tar</code> )” on page 734 |

The following table describes various backup and restore commands.

**TABLE 51–2** Summary of Various Backup Commands

| <b>Command Name</b>             | <b>Aware of File System Boundaries?</b> | <b>Support Multi Volume Backups?</b> | <b>Physical or Logical Copy?</b> |
|---------------------------------|-----------------------------------------|--------------------------------------|----------------------------------|
| <code>volcopy</code>            | Yes                                     | Yes                                  | Physical                         |
| <code>tar</code>                | No                                      | No                                   | Logical                          |
| <code>cpio</code>               | No                                      | Yes                                  | Logical                          |
| <code>pax</code>                | Yes                                     | Yes                                  | Logical                          |
| <code>dd</code>                 | Yes                                     | No                                   | Physical                         |
| <code>ufsdump/ufsrestore</code> | Yes                                     | Yes                                  | Logical                          |

The following sections describe the advantages and disadvantages of each method, and provide step-by-step instructions and examples of how to use the commands.

---

## Copying File Systems Between Disks

Two commands are used to copy file systems between disks:

- `volcopy`
- `dd`

The next section describes how to use the `dd` command to copy file systems between disks.

### Making a Literal File System Copy

The `dd` command makes a literal (block-level) copy of a complete UFS file system to another file system or to a tape. By default, the `dd` command copies standard input to standard output.

---

**Note** – Do not use the `dd` command with variable-length tape drives without first specifying an appropriate block size.

---

You can specify a device name in place of standard input or standard output, or both. In this example, the contents of the diskette are copied to a file in the `/tmp` directory:

```
$ dd < /floppy/floppy0 > /tmp/output.file
2400+0 records in
2400+0 records out
```

The `dd` command reports on the number of blocks it reads and writes. The number after the `+` is a count of the partial blocks that were copied. The default block size is 512 bytes.

The `dd` command syntax is different from most other commands. Options are specified as *keyword=value* pairs, where *keyword* is the option you want to set and *value* is the argument for that option. For example, you can replace standard input and standard output with this syntax:

```
$ dd if=input-file of=output-file
```

To use the *keyword=value* pairs instead of the redirect symbols in the previous example, you would type the following:

```
$ dd if=/floppy/floppy0 of=/tmp/output.file
```

## ▼ How to Copy a Disk (dd)

1. Make sure that the source disk and destination disk have the same disk geometry.
2. Become superuser or assume an equivalent role.
3. Create the `/reconfigure` file so the system will recognize the clone disk to be added when it reboots.

```
touch /reconfigure
```

4. Shut down the system.

```
init 0
```

5. Attach the clone disk to the system.

6. Boot the system.

```
ok boot
```

7. Copy the master disk to the clone disk.

```
dd if=/dev/rdisk/device-name of=/dev/rdisk/device-name bs=block-size
```

`if=/dev/rdisk/device-name` Represents the overlap slice of the master disk device, usually slice 2.

`of=/dev/rdisk/device-name` Represents the overlap slice of the clone disk device, usually slice 2.

`bs=blocksize` Identifies block size, such as 128 Kbytes or 256 Kbytes. A large block size value decreases the time it takes to copy.

For more information, see `dd(1M)`.

8. Check the new file system.

```
fsck /dev/rdisk/device-name
```

9. Mount the clone disk's root (`/`) file system.

```
mount /dev/dsk/device-name /mnt
```

10. Edit the clone disk's `/etc/vfstab` to reference the correct device names.

For example, change all instances of `c0t3d0` with `c0t1d0`.

11. Unmount the clone disk's root (`/`) file system.

```
umount /mnt
```

## 12. Shut down the system.

```
init 0
```

## 13. Boot from the clone disk to single-user mode.

```
boot disk n -s
```

---

**Note** – The `installboot` command is not needed for the clone disk because the boot blocks are copied as part of the overlap slice.

---

## 14. Unconfigure the clone disk.

```
sys-unconfig
```

The system is shut down after it is unconfigured.

## 15. Boot from the clone disk again and provide its system information, such as host name, time zone, and so forth.

```
boot disk n
```

## 16. Log in as superuser to verify the system information after the system is booted.

```
hostname console login:
```

## Example—Copying a Disk (dd)

This example shows how to copy master disk `/dev/rdisk/c0t0d0s2` to clone disk `/dev/rdisk/c0t2d0s2`.

```
touch /reconfigure
init 0
ok boot
dd if=/dev/rdisk/c0t0d0s2 of=/dev/rdisk/c0t2d0s2 bs=128k
fsck /dev/rdisk/c0t2d0s2
mount /dev/dsk/c0t2d0s2 /mnt
cd /mnt/etc
vi vfstab
(Modify entries for the new disk)
cd /
umount /mnt
init 0
boot disk2 -s
sys-unconfig
boot disk2
```

---

## Copying Directories Between File Systems (cpio Command)

You can use the `cpio` (copy in and out) command to copy individual files, groups of files, or complete file systems. This section describes how to use the `cpio` command to copy complete file systems.

The `cpio` command is an archiving program that copies a list of files into a single, large output file. This command inserts headers between the individual files to facilitate recovery. You can use the `cpio` command to copy complete file systems to another slice, another system, or to a media device, such as a tape or diskette.

Because the `cpio` command recognizes end-of-media and prompts you to insert another volume, it is the most effective command, other than `ufsdump`, to use to create archives that require multiple tapes or diskettes.

With the `cpio` command, you frequently use the `ls` and `find` commands to list and select the files you want to copy, and then pipe the output to the `cpio` command.

### ▼ How to Copy Directories Between File Systems (cpio)

1. **Become superuser or assume an equivalent role.**
2. **Change to the appropriate directory.**  

```
cd filesystem1
```
3. **Copy the directory tree from *filesystem1* to *filesystem2* by using a combination of the `find` and `cpio` commands.**

```
find . -print -depth | cpio -pdm filesystem2
```

|        |                                                                            |
|--------|----------------------------------------------------------------------------|
| .      | Starts in the current working directory.                                   |
| -print | Prints the file names.                                                     |
| -depth | Descends the directory hierarchy and prints file names on the way back up. |
| -p     | Creates a list of files.                                                   |
| -d     | Creates directories as needed.                                             |



`-m` Sets the correct modification times on directories.

For more information, see `cpio(1)`.

The files from the directory name you specify are copied and symbolic links are preserved.

You might also specify the `-u` option. This option forces an unconditional copy. Otherwise, older files do not replace newer files. This option might be useful if you want an exact copy of a directory, and some of the files being copied might already exist in the target directory.

4. **Verify that the copy was successful by displaying the destination directory contents.**

```
cd filesystem2
ls
```

5. **If appropriate, remove the source directory.**

```
rm -rf filesystem1
```

## Example—Copying Directories Between File Systems (cpio)

```
cd /data1
find . -print -depth | cpio -pdm /data2
19013 blocks
cd /data2
ls
rm -rf /data1
```

---

## Copying Files and File Systems to Tape

You can use the `tar`, `pax`, and `cpio` commands to copy files and file systems to tape. The command that you choose depends on how much flexibility and precision you require for the copy. Because all three commands use the raw device, you do not need to format or make a file system on tapes before you use them.

**TABLE 51-3** Advantages and Disadvantages of `tar`, `pax`, and `cpio` Commands

| Command           | Function                                                                                                                                                              | Advantages                                                                                                                                                                                                                                                                                                                                                                                                                                                | Disadvantages                                                                                                                                                                                                                                                                                      |
|-------------------|-----------------------------------------------------------------------------------------------------------------------------------------------------------------------|-----------------------------------------------------------------------------------------------------------------------------------------------------------------------------------------------------------------------------------------------------------------------------------------------------------------------------------------------------------------------------------------------------------------------------------------------------------|----------------------------------------------------------------------------------------------------------------------------------------------------------------------------------------------------------------------------------------------------------------------------------------------------|
| <code>tar</code>  | Use to copy files and directory subtrees to a single tape                                                                                                             | <ul style="list-style-type: none"> <li>■ Available on most UNIX operating systems</li> <li>■ Public domain versions are readily available</li> </ul>                                                                                                                                                                                                                                                                                                      | <ul style="list-style-type: none"> <li>■ Is not aware of file system boundaries</li> <li>■ Full pathname length cannot exceed 255 characters</li> <li>■ Does not copy empty directories or special files such as device files</li> <li>■ Cannot be used to create multiple tape volumes</li> </ul> |
| <code>pax</code>  | Use to copy files, special files, or file systems that require multiple tape volumes. Or, when you want to copy files to and from POSIX-compliant systems             | <ul style="list-style-type: none"> <li>■ Better portability than the <code>tar</code> or <code>cpio</code> commands for POSIX-compliant systems</li> <li>■ Multi vendor support</li> </ul>                                                                                                                                                                                                                                                                | Same disadvantages as for the <code>tar</code> command, except that the <code>pax</code> command can create multiple tape volumes                                                                                                                                                                  |
| <code>cpio</code> | Use to copy files, special files, or file systems that require multiple tape volumes. Or, when you want to copy files from SunOS 5.9 systems to SunOS 4.0/4.1 systems | <ul style="list-style-type: none"> <li>■ Packs data onto tape more efficiently than the <code>tar</code> command</li> <li>■ Skips over any bad spots in a tape when restoring</li> <li>■ Provides options for writing files with different header formats, <code>tar</code>, <code>ustar</code>, <code>crc</code>, <code>odc</code>, <code>bar</code>, for portability between different system types</li> <li>■ Creates multiple tape volumes</li> </ul> | The syntax is more difficult than the <code>tar</code> or <code>pax</code> commands                                                                                                                                                                                                                |

The tape drive and device name that you use depend on the hardware configuration for each system. For more information about tape device names, see “Choosing Which Media to Use” on page 739.

---

## Copying Files to Tape (tar Command)

Here are things that you should know before you copy files to tape with the `tar` command:

- Copying files to a tape with the `-c` option to the `tar` command destroys any files already on the tape at or beyond the current tape position.
- You can use file-name substitution wildcards (`?` and `*`) as part of the file names you specify when copying files. For example, to copy all documents with a `.doc` suffix, type `*.doc` as the file-name argument.
- You cannot use file-name substitution wildcards when you extract files from a `tar` archive.

### ▼ How to Copy Files to a Tape (tar)

1. **Change to the directory that contains the files you want to copy.**
2. **Insert a write-enabled tape into the tape drive.**
3. **Copy the files to tape.**

```
$ tar cvf /dev/rmt/n filenames
```

|                           |                                                                                                 |
|---------------------------|-------------------------------------------------------------------------------------------------|
| <code>c</code>            | Indicates that you want to create an archive.                                                   |
| <code>v</code>            | Displays the name of each file as it is archived.                                               |
| <code>f /dev/rmt/n</code> | Indicates that the archive should be written to the specified device or file.                   |
| <code>filenames</code>    | Indicates the files and directories that you want to copy. Separate multiple files with spaces. |

The file names that you specify are copied to the tape, overwriting any existing files on the tape.

4. **Remove the tape from the drive and write the names of the files on the tape label.**
5. **Verify that the files you copied are on the tape.**

```
$ tar tvf /dev/rmt/n
```

For more information on listing files on a `tar` tape, see “How to List the Files on a Tape (tar)” on page 724.

## Example—Copying Files to a Tape (tar)

The following example shows how to copy three files to the tape in tape drive 0.

```
$ cd /export/home/kryten
$ ls reports
reportA reportB reportC
$ tar cvf /dev/rmt/0 reports
a reports/ 0 tape blocks
a reports/reportA 59 tape blocks
a reports/reportB 61 tape blocks
a reports/reportC 63 tape blocks
$ tar tvf /dev/rmt/n
```

## ▼ How to List the Files on a Tape (tar)

1. Insert a tape into the tape drive.
2. Display the tape contents.

```
$ tar tvf /dev/rmt/n
```

|              |                                                                                        |
|--------------|----------------------------------------------------------------------------------------|
| t            | Lists the table of contents for the files on the tape.                                 |
| v            | Used with the t option, and provides detailed information about the files on the tape. |
| f /dev/rmt/n | Indicates the tape device.                                                             |

## Example—Listing the Files on a Tape (tar)

The following example shows a listing of files on the tape in drive 0.

```
$ tar tvf /dev/rmt/0
drwx--x--x 0/1 0 Jul 14 09:24 2001 reports/
-rw-----t 0/1 30000 Jul 14 09:23 2001 reports/reportA
-rw-----t 0/1 31000 Jul 14 09:24 2001 reports/reportB
-rw-----t 0/1 32000 Jul 14 09:24 2001 reports/reportC
```

## ▼ How to Retrieve Files From a Tape (tar)

1. Change to the directory where you want to put the files.
2. Insert the tape into the tape drive.
3. Retrieve the files from the tape.

```
$ tar xvf /dev/rmt/n [filenames]
```

|                           |                                                                                                                                                                 |
|---------------------------|-----------------------------------------------------------------------------------------------------------------------------------------------------------------|
| <code>x</code>            | Indicates that the files should be extracted from the specified archive file. All files on the tape in the specified drive are copied to the current directory. |
| <code>v</code>            | Displays the name of each file as it is retrieved.                                                                                                              |
| <code>f /dev/rmt/n</code> | Indicates the tape device that contains the archive.                                                                                                            |
| <code>filenames</code>    | Specifies a file to retrieve. Separate multiple files with spaces.                                                                                              |

For more information, see `tar(1)`.

#### 4. Verify that the files are copied.

```
$ ls -l
```

## Example—Retrieving the Files on a Tape (`tar`)

The following example shows how to retrieve all the files from the tape in drive 0.

```
$ cd /var/tmp
$ tar xvf /dev/rmt/0
x reports/, 0 bytes, 0 tape blocks
x reports/reportA, 0 bytes, 0 tape blocks
x reports/reportB, 0 bytes, 0 tape blocks
x reports/reportC, 0 bytes, 0 tape blocks
x reports/reportD, 0 bytes, 0 tape blocks
$ ls -l
```

---

**Note** – The names of the files extracted from the tape must exactly match the names of the files that are stored on the archive. If you have any doubts about the names or paths of the files, first list the files on the tape. For instructions on listing the files on the tape, see “How to List the Files on a Tape (`tar`)” on page 724.

---

---

# Copying Files to a Tape With the pax Command

## ▼ How to Copy Files to a Tape (pax)

1. Change to the directory that contains the files you want to copy.
2. Insert a write-enabled tape into the tape drive.
3. Copy the files to tape.

```
$ pax -w -f /dev/rmt/0 filenames
```

|                            |                                                                                                 |
|----------------------------|-------------------------------------------------------------------------------------------------|
| <code>-w</code>            | Enables the write mode.                                                                         |
| <code>-f /dev/rmt/0</code> | Identifies the tape drive.                                                                      |
| <code>filenames</code>     | Indicates the files and directories that you want to copy. Separate multiple files with spaces. |

For more information, see `pax(1)`.

4. Verify that the files are copied to tape.

```
$ pax -f /dev/rmt/0
```

5. Remove the tape from the drive and write the names of the files on the tape label.

## Example—Copying Files to a Tape (pax)

The example shows how to use the `pax` command to copy all the files in the current directory.

```
$ pax -w -f /dev/rmt/0 .
$ pax -f /dev/rmt/0
filea fileb filec
```

---

# Copying Files to Tape With the `cpio` Command

## ▼ How to Copy All Files in a Directory to a Tape (`cpio`)

1. Change to the directory that contains the files you want to copy.
2. Insert a tape that is not write-protected into the tape drive.
3. Copy the files to a tape.

```
$ ls | cpio -oc > /dev/rmt/n
```

```
ls
```

Provides the `cpio` command with a list of file names.

```
cpio -oc
```

Specifies that the `cpio` command should operate in copy-out mode (`-o`) and write header information in ASCII character format (`-c`). This option ensures portability to other vendor's systems.

```
> /dev/rmt/n
```

Specifies the output file.

All files in the directory are copied to the tape in the drive you specify, overwriting any existing files on the tape. The total number of blocks that are copied is shown.

4. Verify that the files are copied to tape.

```
$ cpio -civt < /dev/rmt/n
```

5. Remove the tape from the drive and write the names of the files on the tape label.

## Example—Copying All Files in a Directory to a Tape (`cpio`)

The following example shows how to copy all of the files in the `/export/home/kryten` directory to the tape in tape drive 0.

```
$ cd /export/home/kryten
$ ls | cpio -oc > /dev/rmt/0
```

```

92 blocks
$ cpio -civt < /dev/rmt/0
-rw-----t 1 kryten users 400 Jul 14 09:28 2001, b
drwx--x--x 2 kryten users 0 Jul 14 09:26 2001, letters
-rw-----t 1 kryten users 10000 Jul 14 09:26 2001, letter1
-rw-----t 1 kryten users 10100 Jul 14 09:26 2001, letter2
-rw-----t 1 kryten users 11100 Jul 14 09:27 2001, letter3
-rw-----t 1 kryten users 12300 Jul 14 09:27 2001, letter4
drwx--x--x 2 kryten users 0 Jul 14 09:27 2001, memos
-rw-----t 1 kryten users 400 Jul 14 09:28 2001, memosmemoU
-rw-----t 1 kryten users 500 Jul 14 09:28 2001, memosmemoW
-rw-----t 1 kryten users 100 Jul 14 09:27 2001, memosmemoX
-rw-----t 1 kryten users 200 Jul 14 09:28 2001, memosmemoY
-rw-----t 1 kryten users 150 Jul 14 09:28 2001, memosmemoZ
drwx--x--x 2 kryten users 0 Jul 14 09:24 2001, reports
92 blocks
$

```

## ▼ How to List the Files on a Tape (cpio)

---

**Note** – Listing the table of contents takes a long time because the `cpio` command must process the entire archive.

---

1. Insert an archive tape into the tape drive.
2. List the files on the tape.

```
$ cpio -civt < /dev/rmt/n
```

|                              |                                                                                                                                |
|------------------------------|--------------------------------------------------------------------------------------------------------------------------------|
| <code>-c</code>              | Specifies that the <code>cpio</code> command should read files in ASCII character format.                                      |
| <code>-i</code>              | Specifies that the <code>cpio</code> command should operate in copy-in mode even though it's only listing files at this point. |
| <code>-v</code>              | Displays the output in a format that is similar to the output from the <code>ls -l</code> command.                             |
| <code>-t</code>              | Lists the table of contents for the files on the tape in the tape drive that you specify.                                      |
| <code>&lt; /dev/rmt/n</code> | Specifies the input file of an existing <code>cpio</code> archive.                                                             |

### Example—Listing the Files on a Tape (cpio)

The following example shows how to list the files on the tape in drive 0.



```

$ cpio -civt < /dev/rmt/0
drwx--x--x 2 kryten users 0 Jul 14 09:34 2001, answers
-rw-----t 1 kryten users 800 Jul 14 09:36 2001, b
drwx--x--x 2 kryten users 0 Jul 14 09:32 2001, sc.directives
-rw-----t 1 kryten users 200000 Jul 14 09:35 2001, direct241
drwx--x--x 2 kryten users 0 Jul 14 09:32 2001, tests
-rw-----t 1 kryten users 800 Jul 14 09:36 2001, test13times
396 blocks

```

## ▼ How to Retrieve All Files From a Tape (cpio)

If the archive was created using relative path names, the input files are built as a directory within the current directory when you retrieve the files. If, however, the archive was created with absolute path names, the same absolute paths are used to re-create the file on your system.



---

**Caution** – The use of absolute path names can be dangerous because you might overwrite existing files on your system.

---

1. Change to the directory where you want to put the files.
2. Insert the tape into the tape drive.
3. Extract all files from the tape.

```
$ cpio -icvd < /dev/rmt/n
```

|              |                                                                                                                      |
|--------------|----------------------------------------------------------------------------------------------------------------------|
| -i           | Extracts files from standard input.                                                                                  |
| -c           | Specifies that <code>cpio</code> should read files in ASCII character format.                                        |
| -v           | Displays the files as they are retrieved in a format that is similar to the output from the <code>ls</code> command. |
| -d           | Creates directories as needed.                                                                                       |
| < /dev/rmt/n | Specifies the output file.                                                                                           |

4. Verify that the files are copied.

```
$ ls -l
```

## Example—Retrieving All Files From a Tape (cpio)

The following example shows how to retrieve all files from the tape in drive 0.

```
$ cd /var/tmp
cpio -icvd < /dev/rmt/0
answers
sc.directives
tests
8 blocks
$ ls -l
```

## ▼ How to Retrieve Specific Files From a Tape (cpio)

1. Change to the directory where you want to put the files.
2. Insert the tape into the tape drive.
3. Retrieve a subset of files from the tape.

```
$ cpio -icv "*file" < /dev/rmt/n
```

|                      |                                                                                                                                                                                      |
|----------------------|--------------------------------------------------------------------------------------------------------------------------------------------------------------------------------------|
| -i                   | Extracts files from standard input.                                                                                                                                                  |
| -c                   | Specifies that the <code>cpio</code> command should read headers in ASCII character format.                                                                                          |
| -v                   | Displays the files as they are retrieved in a format that is similar to the output from the <code>ls</code> command.                                                                 |
| <i>"*file"</i>       | Specifies that all files that match the pattern are copied to the current directory. You can specify multiple patterns, but each pattern must be enclosed in double quotation marks. |
| < /dev/rmt/ <i>n</i> | Specifies the input file.                                                                                                                                                            |

For more information, see `cpio(1)`.

4. Verify that the files are copied.

```
$ ls -l
```

## Example—Retrieving Specific Files From a Tape (cpio)

The following example shows how to retrieve all files with the `chapter` suffix from the tape in drive 0.

```
$ cd /home/smith/Book
$ cpio -icv "*chapter" < /dev/rmt/0
Boot.chapter
Directory.chapter
Install.chapter
Intro.chapter
```

```
31 blocks
$ ls -l
```

---

## Copying Files to a Remote Tape Device

### ▼ How to Copy Files to a Remote Tape Device (tar and dd)

1. The following prerequisites must be met to use a remote tape drive:
  - a. The local hostname and optionally, the username of the user doing the copy, must appear in the remote system's `/etc/hosts.equiv` file. Or, the user doing the copy must have his or her home directory accessible on the remote machine, and have the local machine name in `$HOME/.rhosts`.  
For more information, see `hosts.equiv(4)`.
  - b. An entry for the remote system must be in the local system's `/etc/inet/hosts` file or in the name service `hosts` file.
2. To test whether you have the appropriate permission to execute a remote command, try the following:

```
$ rsh remotehost echo test
```

If `test` is echoed back to you, you have permission to execute remote commands. If `Permission denied` is echoed, check your setup as described in step 1.

3. Change to the directory where you want to put the files.
4. Insert the tape into the tape drive.
5. Copy the files to a remote tape drive.

```
$ tar cvf - filenames | rsh remote-host dd of=/dev/rmt/n obs=block-size
```

|                                |                                                                                              |
|--------------------------------|----------------------------------------------------------------------------------------------|
| <code>tar cf</code>            | Creates a tape archive, lists the files as they are archived, and specifies the tape device. |
| <code>-</code> (Hyphen)        | Represents a place holder for the tape device.                                               |
| <code>filenames</code>         | Identifies the files to be copied.                                                           |
| <code>  rsh remote-host</code> | Pipes the <code>tar</code> command's output to a remote shell.                               |

|                               |                                 |
|-------------------------------|---------------------------------|
| <code>dd of=/dev/rmt/n</code> | Represents the output device.   |
| <code>obs=block-size</code>   | Represents the blocking factor. |

6. Remove the tape from the drive and write the names of the files on the tape label.

## Example—Copying Files to a Remote Tape Drive (`tar` and `dd`)

```
tar cvf - * | rsh mercury dd of=/dev/rmt/0 obs=126b
a answers/ 0 tape blocks
a answers/test129 1 tape blocks
a sc.directives/ 0 tape blocks
a sc.directives/sc.190089 1 tape blocks
a tests/ 0 tape blocks
a tests/test131 1 tape blocks
6+9 records in
0+1 records out
```

## ▼ How to Extract Files From a Remote Tape Device

1. Insert the tape into the tape drive.
2. Change to a temporary directory.

```
$ cd /var/tmp
```

3. Extract the files from a remote tape device.

```
$ rsh remote-host dd if=/dev/rmt/n | tar xvBpf -
```

|                              |                                                                                                                          |
|------------------------------|--------------------------------------------------------------------------------------------------------------------------|
| <code>rsh remote-host</code> | Indicates a remote shell that is started to extract the files from the tape device by using the <code>dd</code> command. |
|------------------------------|--------------------------------------------------------------------------------------------------------------------------|

|                               |                             |
|-------------------------------|-----------------------------|
| <code>dd if=/dev/rmt/n</code> | Indicates the input device. |
|-------------------------------|-----------------------------|

|                            |                                                                                                                    |
|----------------------------|--------------------------------------------------------------------------------------------------------------------|
| <code>  tar xvBpf -</code> | Pipes the output of the <code>dd</code> command to the <code>tar</code> command that is used to restore the files. |
|----------------------------|--------------------------------------------------------------------------------------------------------------------|

4. Verify that the files have been extracted.

```
$ ls -l /var/tmp
```

## Example—Extracting Files From a Remote Tape Drive

```
$ cd /var/tmp
$ rsh mercury dd if=/dev/rmt/0 | tar xvBpf -
```

```
x answers/, 0 bytes, 0 tape blocks
x answers/test129, 48 bytes, 1 tape blocks
20+0 records in
20+0 records out
x sc.directives/, 0 bytes, 0 tape blocks
x sc.directives/sc.190089, 77 bytes, 1 tape blocks
x tests/, 0 bytes, 0 tape blocks
x tests/test131, 84 bytes, 1 tape blocks
$ ls -l
```

---

## Copying Files and File Systems to Diskette

Before you can copy files or file systems to diskette, you must format the diskette. For information on how to format a diskette, see Chapter 19.

Use the `tar` command to copy UFS files to a single formatted diskette.

Use the `cpio` command if you need to copy UFS files to multiple formatted diskettes. The `cpio` command recognizes end-of-media and prompts you to insert the next volume.

---

**Note** – The use of the `cpio` command to copy UFS files to multiple formatted diskettes is not a straightforward procedure because of volume management.

---

## Things You Should Know When Copying Files to Diskettes

- Copying files to a formatted diskette by using the `tar -c` command destroys any files that are already on the diskette.
- A diskette that contains a `tar` image is not mountable.
- If you need a multiple-volume interchange utility, use the `cpio` command. The `tar` command is only a single-volume utility.

For more information, see `tar(1)`.

## ▼ How to Copy Files to a Single Formatted Diskette (tar)

1. Change to the directory that contains the files you want to copy.
2. Insert a formatted diskette that is not write-protected into the drive.
3. Make the diskette available.

```
$ volcheck
```

4. Reformat the diskette if necessary.

```
$ rmformat -U /dev/rdiskette
Formatting will erase all the data on disk.
Do you want to continue? (y/n)y
```

5. Copy the files to diskette.

```
$ tar cvf /vol/dev/aliases/floppy0 filename ...
```

The file names that you specify are copied to the diskette, overwriting any existing files on the diskette.

6. Verify that the files are copied.

```
$ tar tvf /vol/dev/aliases/floppy0
```

For more information on listing files, see “How to List the Files on a Diskette (tar)” on page 735.

7. Remove the diskette from the drive.
8. Write the names of the files on the diskette label.

## Example—Copying Files to a Single Formatted Diskette (tar)

The following example shows how to copy two files to a diskette.

```
$ volcheck
$ cd /home/smith
$ ls evaluation*
evaluation.doc evaluation.doc.backup
$ tar cvf /vol/dev/aliases/floppy0 evaluation*
a evaluation.doc 86 blocks
a evaluation.doc.backup 84 blocks
$ tar tvf /vol/dev/aliases/floppy0
```

## ▼ How to List the Files on a Diskette (tar)

1. Insert a diskette into the drive.
2. Make the diskette available.

```
$ volcheck
```

3. List the files on a diskette.

```
$ tar tvf /vol/dev/aliases/floppy0
```

## Example—Listing the Files on a Diskette (tar)

The following example shows how to list the files on a diskette.

```
$ volcheck
tar tvf /vol/dev/aliases/floppy0
rw-rw-rw-6693/10 44032 Jun 9 15:45 evaluation.doc
rw-rw-rw-6693/10 43008 Jun 9 15:55 evaluation.doc.backup
$
```

## ▼ How to Retrieve Files From a Diskette (tar)

1. Change to the directory where you want to put the files.
2. Insert the diskette into the drive.
3. Make the diskette available.

```
$ volcheck
```

4. Retrieve files from the diskette.

```
$ tar xvf /vol/dev/aliases/floppy0
```

All files on the diskette are copied to the current directory.

5. Verify that the files have been retrieved.

```
$ ls -l
```

6. Remove the diskette from the drive.

## Examples—Retrieving Files From a Diskette (tar)

The following example shows how to retrieve all the files from a diskette.

```
$ volcheck
$ cd /home/smith/Evaluations
$ tar xvf /vol/dev/aliases/floppy0
```

```
x evaluation.doc, 44032 bytes, 86 tape blocks
x evaluation.doc.backup, 43008 bytes, 84 tape blocks
$ ls -l
```

The following example shows how to retrieve an individual file from a diskette.

```
$ volcheck
$ tar xvf /vol/dev/aliases/floppy0 evaluation.doc
x evaluation.doc, 44032 bytes, 86 tape blocks
$ ls -l
```

The file names that you specify are extracted from the diskette and placed in the current working directory.

## How to Archive Files to Multiple Diskettes

If you are copying large files onto diskettes, you want to be prompted to replace a full diskette with another formatted diskette. The `cpio` command provides this capability. The `cpio` commands you use are the same as you would use to copy files to tape, except you would specify `/vol/dev/aliases/floppy0` as the device instead of the tape device name.

For information on how to use the `cpio` command, see “How to Copy All Files in a Directory to a Tape (`cpio`)” on page 727.

---

## Copying Files With a Different Header Format

Archives that are created with the SunOS 5.9 `cpio` command might not be compatible with older SunOS releases. The `cpio` command allows you to create archives that can be read with several other formats. You specify these formats by using the `-H` option and one of these arguments:

- `crc` or `CRC` – ASCII header with checksum
- `ustar` or `USTAR` – IEEE/P1003 Data Interchange
- `tar` or `TAR` – tar header and format
- `odc` – ASCII header with small device numbers
- `bar` – bar header and format

The syntax for using the header options is as follows:

```
cpio -o -H header-option < file-list > output-archive
```



## How to Create an Archive for Older SunOS Releases

Use the `cpio` command to create the archive.

```
$ cpio -oH odc < file-list > /dev/rmt/n
```

The `-H` arguments have the same meaning for input as they do for output. If the archive was created with the `-H` option, you must use the same option when the archive is read back in or the `cpio` command will fail. The following example includes the `cpio` error message.

### Example—Creating an Archive for Older SunOS Releases

```
$ find . -print | cpio -oH tar > /tmp/test
113 blocks
$ cpio -iH bar < /tmp/test
cpio: Invalid header "bar" specified
USAGE:
 cpio -i[bcdfkmrstuvBSV6] [-C size] [-E file] [-H hdr]
 [-I file [-M msg]] [-R id] [patterns]
 cpio -o[acvABLV] [-C size] [-H hdr] [-O file [-M msg]]
 cpio -p[adlmuvLV] [-R id] directory
```

When you create an archive with different options, always write the command syntax on the media label along with the names of the files or file system on the archive.

If you do not know which `cpio` options were used when an archive was created, all you can do is experiment with different option combinations to see which ones allow the archive to be read.

For a complete list of options, see `cpio(1)`.

## Retrieving Files Created With the `bar` Command

To retrieve files from diskettes that were archived by using the SunOS 4.0 or 4.1 `bar` command, use the `cpio -H bar` command.

---

**Note** – You can use only the `-H bar` option with the `-i` option to retrieve files. You cannot create files with the `bar` header option.

---

### ▼ How to Retrieve `bar` Files From a Diskette

1. Change to the directory where you want to put the files.
2. Insert the diskette into the drive.

**3. Make the diskette available.**

```
$ volcheck
```

**4. Retrieve bar files from a diskette.**

All files on the diskette are copied to the current directory.

```
$ cpio -ivH bar < /vol/dev/aliases/floppy0
```

## Managing Tape Drives (Tasks)

---

This chapter describes how to manage tape drives.

This is a list of the step-by-step instructions in this chapter.

- “How to Display Tape Drive Status” on page 742
- “How to Retension a Magnetic Tape Cartridge” on page 743
- “How to Rewind a Magnetic Tape Cartridge” on page 744

---

## Choosing Which Media to Use

You typically back up Solaris systems by using the following tape media:

- 1/2-inch reel tape
- 1/4-inch streaming cartridge tape
- 8-mm cartridge tape
- 4-mm cartridge tape (DAT)

You can perform backups with diskettes, but doing so is time-consuming and cumbersome.

The media that you choose depends on the availability of the equipment that supports it and of the media (usually tape) that you use to store the files. Although you must do the backup from a local system, you can write the files to a remote device.

The following table shows typical media that is used for backing up file systems and shows the storage capacity for each media. Capacity depends on the type of drive and the data being written to the tape.

**TABLE 52-1** Media Storage Capacities

| Media                                   | Capacity              |
|-----------------------------------------|-----------------------|
| 1/2-inch reel tape                      | 140 Mbytes (6250 bpi) |
| 2.5-Gbyte 1/4 inch cartridge (QIC) tape | 2.5 Gbytes            |
| DDS3 4-mm cartridge tape (DAT)          | 12–24 Gbytes          |
| 14-Gbyte 8-mm cartridge tape            | 14 Gbytes             |
| DLT™ 7000 1/2-inch cartridge tape       | 35–70 Gbytes          |

---

## Backup Device Names

You specify a tape or diskette to use for backup by supplying a logical device name. This name points to the subdirectory that contains the “raw” device file and includes the logical unit number of the drive. Tape drive naming conventions use a logical, not a physical, device name. The following table shows this naming scheme.

**TABLE 52-2** Basic Device Names for Backup Devices

| Device Type | Name                                       |
|-------------|--------------------------------------------|
| Tape        | <code>/dev/rmt/<i>n</i></code>             |
| Diskette    | <code>/vol/dev/rdiskette0/unlabeled</code> |

In general, you specify a tape drive device as shown in the following figure.

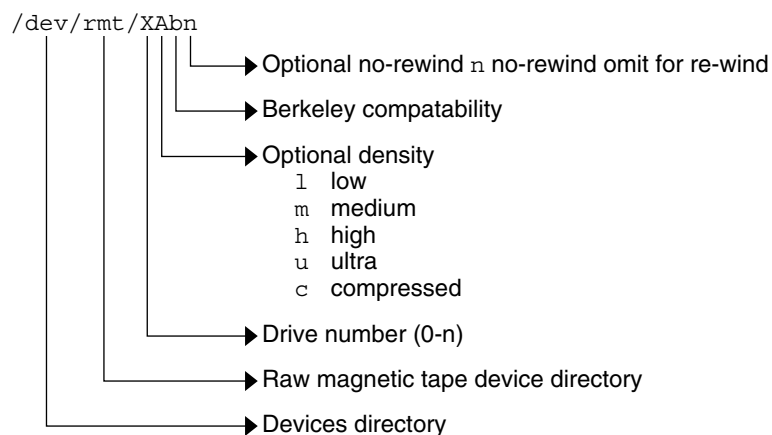

**FIGURE 52-1** Tape Drive Device Names

If you don't specify the density, a tape drive typically writes at its "preferred" density, which usually means the highest density the tape drive supports. Most SCSI drives can automatically sense the density or format on the tape and read it accordingly. To determine the different densities that are supported for a drive, look at the `/dev/rmt` subdirectory. This subdirectory includes the set of tape device files that support different output densities for each tape.

Also, a SCSI controller can have a maximum of seven SCSI tape drives.

## Specifying the Rewind Option for a Tape Drive

Normally, you specify a tape drive by its logical unit number, which can run from 0 to *n*. The following table describes how to specify tape device names with a rewind or no rewind option.

**TABLE 52-3** Specifying Rewind or No-Rewind for a Tape Drive

| Drive and Rewind Value  | Use This Option          |
|-------------------------|--------------------------|
| First drive, rewind     | <code>/dev/rmt/0</code>  |
| First drive, no rewind  | <code>/dev/rmt/0n</code> |
| Second drive, rewind    | <code>/dev/rmt/1</code>  |
| Second drive, no rewind | <code>/dev/rmt/1n</code> |

## Specifying Different Densities for a Tape Drive

By default, the drive writes at its “preferred” density, which is usually the highest density the tape drive supports. If you do not specify a tape device, the command writes to drive number 0 at the default density the device supports.

To transport a tape to a system whose tape drive supports only a certain density, specify a device name that writes at the desired density. The following table describes how to specify different densities for a tape drive.

**TABLE 52-4** Specifying Different Densities for a Tape Drive

| Drive, Density, and Rewind Value        | Use this Option           |
|-----------------------------------------|---------------------------|
| First drive, low density, rewind        | <code>/dev/rmt/0l</code>  |
| First drive, low density, no rewind     | <code>/dev/rmt/0ln</code> |
| Second drive, medium density, rewind    | <code>/dev/rmt/1m</code>  |
| Second drive, medium density, no rewind | <code>/dev/rmt/1mn</code> |

The unit and density characters are shown in “Backup Device Names” on page 740.

---

## Displaying Tape Drive Status

You can use the `status` option with the `mt` command to get status information about tape drives. The `mt` command reports information about any tape drives that are described in the `/kernel/drv/st.conf` file.

### ▼ How to Display Tape Drive Status

1. Load a tape into the drive you want information about.
2. Display tape drive status with the `mt` command.

```
mt -f /dev/rmt/n status
```

3. Repeat steps 1-2, substituting tape drive numbers 1, 2, 3, and so on to display information about all available tape drives.

### Example—Displaying Tape Drive Status

The following example shows the status for a QIC-150 tape drive (`/dev/rmt/0`) and an Exabyte tape drive (`/dev/rmt/1`).

```

$ mt -f /dev/rmt/0 status
Archive QIC-150 tape drive:
 sense key(0x0)= No Additional Sense residual= 0 retries= 0
 file no= 0 block no= 0
$ mt -f /dev/rmt/1 status
Exabyte EXB-8200 8mm tape drive:
sense key(0x0)= NO Additional Sense residual= 0 retries= 0
file no= 0 block no= 0

```

The following example shows a quick way to poll a system and locate all of its tape drives.

```

$ for drive in 0 1 2 3 4 5 6 7
> do
> mt -f /dev/rmt/$drive status
> done
Archive QIC-150 tape drive:
 sense key(0x0)= No Additional Sense residual= 0 retries= 0
 file no= 0 block no= 0
/dev/rmt/1: No such file or directory
/dev/rmt/2: No such file or directory
/dev/rmt/3: No such file or directory
/dev/rmt/4: No such file or directory
/dev/rmt/5: No such file or directory
/dev/rmt/6: No such file or directory
/dev/rmt/7: No such file or directory
$

```

---

## Handling Magnetic Tape Cartridges

If errors occur when a tape is being read, retension the tape, clean the tape drive, and then try again.

### How to Retension a Magnetic Tape Cartridge

Retension a magnetic tape cartridge with the `mt` command.

For example:

```

$ mt -f /dev/rmt/1 retension
$

```

---

**Note** – Do not retension non-QIC tape drives.

---

## How to Rewind a Magnetic Tape Cartridge

To rewind a magnetic tape cartridge, use the `mt` command.

For example:

```
$ mt -f /dev/rmt/1 rewind
$
```

---

## Guidelines for Drive Maintenance and Media Handling

A backup tape that cannot be read is useless. So, to clean and check your tape drives periodically to ensure correct operation. See your hardware manuals for instructions on procedures for cleaning a tape drive. You can check your tape hardware by doing either of the following:

- Copying some files to the tape, reading the files back, and then comparing the original with the copy.
- Using the `-v` option of the `ufsdump` command to verify the contents of the media with the source file system. The file system must be unmounted or completely idle for the `-v` option to be effective.

Be aware that hardware can fail in ways that the system does not report.

Always label your tapes after a backup. If you are using a backup strategy similar to those strategies suggested in Chapter 46, you should indicate on the label “Tape A,” “Tape B,” and so forth. This label should never change. Every time you do a backup, make another tape label containing the backup date, the name of the machine and file system backed up, backup level, the tape number (1 of *n*, if it spans multiple volumes), plus any information specific to your site.

Store your tapes in a dust-free safe location, away from magnetic equipment. Some sites store archived tapes in fireproof cabinets at remote locations.

You should create and maintain a log that tracks which media (tape volume) stores each job (backup) and the location of each backed-up file.



# Index

---

## Numbers and Symbols

- 4.3 Tahoe file system, 533
- 9660 CD format, 232

## A

### accessing

- disk devices, 431, 434
- pathnames for removable media, 228
- removable media (how to), 233
- tape devices, 434

### adding

- a device driver (how to), 372
- a disk (overview)
  - SPARC, 482
  - x86, 492
- a package, example of, 318
- a package from a mounted CD (example of), 318
- a peripheral device (how to), 371
- a SCSI device to a SCSI bus (how to), 382
- diskless client OS services (how to), 134
- entry to `/etc/vfstab` file (how to), 565
- multiple versions of a package, 282
- packages (prerequisites), 281
- packages from a spool directory (example of), 321
- packages from remote package server (example of), 319
- packages to a spool directory (example of), 323
- packages with administration files, 283

### adding (Continued)

- packages with base directory, 284
- PCI adapter card (how to), 389
- preparing to add OS services for diskless clients (how to), 132
- run control script (how to), 166
- server and client support
  - description, 119
  - software with Solaris Product Registry, 288
- swap to `vfstab`, 609
- USB audio device, 418
- USB camera (how to), 415
- USB mass storage device with `vold` running, 411
- USB mass storage device without `vold` running, 411
- user initialization files, 82

### Admintool

- adding and removing packages
  - overview, 325
  - adding packages (how to), 326, 327
  - removing packages (how to), 327

### aging user passwords, 74, 82, 83

### aliases, user login names vs., 71

### allocated inodes, 620

### appliances, definition, 122

### archiving

- files to multiple diskettes with `cpio` command (how to), 736
- for older SunOS releases with `cpio` command (how to), 737

### ASN.1 (Abstract Syntax Notation 1), 276

### AutoClient, definition, 122

- autoconfiguration process, 365
- autofs, 547
- automounting
  - and /home, 548
  - user home directories, 76

## B

- backing up
  - a UFS snapshot with the `tar` command (how to), 688
  - and restoring file systems
    - commands for, 654
    - definition, 654
  - choosing file systems to, 655
  - file systems to tape (how to), 674
  - full and incremental, defined, 657
  - preparing for (overview), 672
  - reasons for, 655
  - types of, 657
  - UFS snapshot (full) (how to), 687
  - UFS snapshot information (incremental) (how to), 687
- backup
  - device names, 740
  - full (level 0) backup to tape (how to), 674
  - record of incremental, 705
- backup schedules
  - daily cumulative, weekly cumulative backups, 662
  - daily cumulative, weekly incremental backups, 663
  - daily incremental, weekly cumulative backups, 664
  - examples, 662, 668
  - for a server, 665
  - guidelines for, 660
  - recommendations, 668
  - using dump levels for, 660
- bad block numbers, 621
- bad inode number, 623
- bad superblock, 628
- banner command (PROM), 181
- `bar` command, retrieving files created with (how to), 737
- base directory (`basedir`), 282, 284
- `base64`, 276

- `basedir` keyword (administration files), 282, 284
- becoming superuser (root), 48
- `bin` group, 71
- block disk device interface
  - defined, 431
  - when to use, 432
- blocks
  - bad, 621
  - boot, 640
  - data, 642
  - directory data, 622
  - duplicate, 621
  - free, 642
  - indirect, 622
  - logical size, 643
  - regular data, 623
  - special inodes, 620
- boot block, 640
- boot-from PROM setting, 183
- boot process
  - description (SPARC), 214
  - x86, 220
- boot types, description, 149
- booting
  - a diskless client (how to), 137
  - a system, guidelines, 150
  - and PC BIOS, 214
  - for recovery purposes (how to)
    - SPARC, 191
    - x86, 204
  - from the network
    - SPARC, 189
    - x86, 203
  - interactively (how to)
    - SPARC, 188
    - x86, 201
  - the Solaris Device Configuration Assistant (how to)
    - x86, 199
  - to force a crash dump and reboot (how to)
    - SPARC, 194
    - x86, 210
  - to run level 3
    - SPARC, 186
  - to run level 3 (how to)
    - x86, 199

- booting (Continued)
  - to run level S
    - SPARC, 187
  - to run level S (how to)
    - x86, 200
  - with the kernel debugger (how to)
    - SPARC, 193
    - x86, 209
- Bourne shell
  - See also* user initialization files
  - basic features, 91
  - environment variables and, 92, 96
  - shell (local) variables and, 92, 94
- Break key, 190, 193
- BSD Fat Fast File system, 533
- bus-oriented disk controllers, 433
- bytes (number per inode), 645

## C

- C shell
  - basic features, 91
  - environment variables and, 92, 96
  - shell (local) variables and, 92, 94
  - user initialization files and, 89, 97, 104
    - See* user initialization files
  - creating, 91
    - to reference a site initialization file, 90
- CacheFS file systems
  - checking with `fsck` command (example of), 588
  - checking with `fsck` command (how to), 588
  - collecting CacheFS statistics (overview), 598
  - creating (how to), 579
  - creating a packing list (how to), 592
  - deleting (how to), 587
  - displaying information about (how to), 585
  - displaying packed files (example of), 591
  - displaying packed files (how to), 591
  - locating CacheFS log file, 600
  - mounting (how to), 580
  - overview, 577
  - packing files in the cache (how to), 593
  - packing with `cachefspack` command (how to), 590
  - packing with `cachefspack` command (overview), 589

- CacheFS file systems (Continued)
  - parameters, 577
  - setting up CacheFS logging (how to), 600
  - stopping CacheFS logging, 601
  - troubleshooting `cachefspack` errors, 594
  - unpacking files (how to), 593
  - viewing CacheFS statistics, 602
  - viewing working set (cache) size, 601
- `cachefspack` command
  - how to use, 590
  - overview, 589
- cartridge tape, retensioning, 743
- causes of file system damage, 616
- CD-ROM devices
  - adding software from mounted CD
    - example of, 318
- CDPATH environment variable, 93
- `cdrw` command
  - checking CD media (how to), 261
  - copying a CD (how to), 267
  - creating a multi-session data CD (how to), 263
  - creating an audio CD (how to), 265
  - description, 257
  - erasing CD-RW media (how to), 267
  - extracting an audio track on a CD (how to), 266
  - identifying CD media (how to), 260
  - restricting access to (how to), 260
  - writing data and audio CDs (overview), 259
- CDs
  - ISO 9660 format, 232
  - names, 230
  - UFS CDs
    - SPARC vs. x86 format, 232
- certificate, trusted
  - definition, 275
  - importing, 311
  - obtaining, 279
  - overview, 276
- certificate authority, 279
- certificates
  - displaying, 313
  - removing, 314
- `cfgadm`
  - PCI hot-plugging (overview), 373
  - SCSI hot-plugging (overview), 373
- `cfsadmin` command, 579, 587

- changing
  - default boot device
    - SPARC, 183
  - directory ownership for user accounts, 81
  - file ownership for user accounts, 81
  - primary USB audio device (how to), 420
  - user ID numbers, 81
  - user login names, 81
  - user passwords
    - by user, 74
    - frequency of, 74, 86
    - Users Tool, 82
- character special inodes, 620
- checking
  - and repairing file systems, 624
  - CacheFS file systems (example of), 588
  - CacheFS file systems (how to), 588
  - CD media (how to), 261
  - file system size, 619
  - file systems interactively, 625
  - format and type of inodes, 620
  - free blocks, 619
  - free inodes, 620
  - inode list for consistency, 619
  - installed packages (example of), 323
- clean shutdown, 170
- clri command, 537
- collecting, CacheFS statistics (overview), 598
- configuring
  - a SCSI controller with `cfgadm` command (how to), 379
  - a SCSI device with `cfgadm` command (how to), 380
  - a USB device (how to), 427
- connecting
  - a SCSI controller (how to), 382
  - a USB device (how to), 428
- controlling file and directory access, 69, 96
- copying
  - a CD (how to), 267
  - all files in a directory to tape with `cpio` command (how to), 727
  - complete file systems (`dd`), 717
  - directories between file systems with `cpio` command (how to), 720
  - directories between file systems with `cpio` command (overview), 720
  - files to diskette (overview), 733
- copying (Continued)
  - files to diskette with `tar` command (how to), 734
  - files to remote tape with `tar` and `dd` commands (how to), 731
  - files to tape with `pax` command (how to), 726
  - files to tape with `tar` command (how to), 723
  - files with different header format with `cpio` command (how to), 736
  - groups of files with `cpio` command (overview), 720
  - individual files with `cpio` command (overview), 720
  - removable media information (how to), 234
- copying disks, with the `dd` command (how to), 718
- `cp` command, copying removable media information (how to), 234
- `cpio` command, 727
  - copying directories between file systems (how to), 720
  - copying files with different header format (how to), 736
  - extract all files from tape (how to), 729
  - listing files on tape (how to), 728
  - overview, 720
  - retrieving specific files from tape (how to), 730
- creating
  - a data CD file system (how to), 262
  - a full backup of UFS snapshot information (how to), 686
  - a packing list (how to), 592
  - a Solaris `fdisk` partition (how to), 495
  - a UFS file system (how to), 552
  - a UFS snapshot
    - example of, 684
  - a UFS snapshot (how to), 684
  - an audio CD (how to), 265
  - an incremental backup of UFS snapshot (how to), 687
  - compatible archives with `cpio` command (how to), 737
  - disk slices and labeling a disk (how to)
    - SPARC, 484
    - x86, 501

- creating (Continued)
  - file systems (overview), 552
  - loopback file system (overview), 556
  - multi-session data CD (how to), 263
  - swap file, 611
  - temporary file system (TMPFS) (how to), 554
- .cshrc file
  - customizing, 75, 91, 97
  - description, 89
- custom parameters for file systems, 643
- customizing user initialization files (how to), 103
- cylinder group, 639

## D

- daemon group, 71
- daily cumulative backups, 661
- daily discrete backups, 661
- damage to file systems, 616
- data block, 623, 642
- data directory blocks, 622
- dd command
  - cloning disks (how to), 718
  - copying files to remote tape with tar command (how to), 731
  - overview, 717
  - retrieving files from remote tape drive with tar command (how to), 732
- default
  - file system for /tmp (TMPFS), 536
  - mount options, 567
  - SunOS file system, 539
- deleting
  - CacheFS file systems (how to), 587
  - diskless client OS services (example of), 138
  - diskless client OS services (how to), 137
  - UFS snapshot information
    - example of, 686
  - UFS snapshot information (how to), 685
  - user home directories, 82
  - user mailboxes, 82
- DER (Distinguished Encoding Rules), 276
- detecting end of media
  - cpio command, 720
  - ufsdump command, 704

- determining
  - file system types, 548
  - mounted file systems, 564
  - system's run level (how to), 156
  - tape device name, 691
  - type of tape drive, 691
  - who is logged in to a system, 171
- /dev/dsk directory, 431
- /dev/rdisk directory, 431
- devfsadm command, 430
- device driver
  - adding, 372
  - defined, 364
- device instance name, 430
- device names
  - backup, 740
  - finding a file system name, 690
  - finding tape, 691
- devices
  - accessing, 429
  - when to turn off power to, 176
- df command, 432, 537
- dfstab file
  - configuring for shared local removable media (how to), 239
  - user home directory sharing and, 108
- direct I/O, 542
- directories
  - base directory (basedir), 282, 284
  - changing ownership for user accounts, 81
  - controlling access to, 69, 96
  - copying between file systems with cpio command (overview), 720
  - home, 75
  - inodes, 620
  - PATH environment variable and, 93, 94, 95
  - /proc, 536
  - skeleton, 75, 82
  - /tmp, 536
  - unallocated blocks, 623
- disabling
  - run control script (how to), 167
  - user accounts
    - passwords and, 83, 86
    - Users Tool, 83
- disconnecting
  - a SCSI controller (how to), 381
  - a USB device subtree (how to), 428

- disk
  - adding to a (overview)
    - x86, 492
  - automatic configuration of SCSI drives, 474
  - connecting a system disk
    - x86, 492
  - creating disk slices and labeling a disk (how to)
    - x86, 501
  - formatting a (overview), 453
  - repairing defective sectors, 476, 478
  - when to format (overview), 462
- disk-based file systems, 533
- disk controllers, 432
- disk label
  - creating (overview), 467
  - description, 454
  - examining with `prtvtoc` command (how to), 469
- disk slices
  - defined, 445
  - determining which slices to use, 450
  - displaying information about (overview), 465
  - requirements for system configurations, 450
- diskettes
  - accessing on other systems (example of), 242
  - archiving files to multiple with `cpio` command (how to), 736
  - copying files to with `tar` command (how to), 734
  - listing files on with `tar` command (how to), 735
  - loading
    - with volume management, 249
  - loading with volume management (how to), 248
  - mounting remotely (example of), 242
  - retrieving files from with `tar` command (how to), 735
- diskless client management commands
  - `smoservice`
    - add OS services, 126
- diskless clients
  - adding OS services for (how to), 134
  - booting (how to), 137
  - definition, 121
  - deleting OS services (example of), 138
- diskless clients (Continued)
  - deleting OS services (how to), 137
  - preparing to add OS services (how to), 132
- disks
  - adding to a (overview)
    - SPARC, 482
  - connecting a secondary disk (example of)
    - SPARC, 487
  - connecting a secondary disk (how to)
    - SPARC, 483
    - x86, 493
  - connecting a system disk (how to)
    - SPARC, 483
  - creating a file system on a new disk (how to)
    - SPARC, 489
    - x86, 502
  - creating disk slices and labeling a disk (example of)
    - SPARC, 486
  - creating disk slices and labeling a disk (how to)
    - SPARC, 485
  - determining if formatted (how to), 463
  - displaying slice information (how to), 465
  - examining a disk label (how to), 469
  - formatting a (how to), 463
  - identifying on a system (how to), 460
  - labeling a (how to), 467
  - recovering a corrupted disk label (how to), 471
  - recovering a corrupted disk label (overview), 470
- displaying
  - detailed information about packages (example of), 322
  - device information, 369
  - disk slice information (overview), 465
  - environment variables, 91
  - installed software information, 321
  - packed files (example of), 591
  - packed files (how to), 591
  - PCI device information (how to), 388
  - removable media user (how to), 236
  - SCSI device configuration information (how to), 378
  - swap space, 610
  - system configuration information, 366, 368
  - UFS snapshot information (how to), 684

- displaying (Continued)
  - USB device information (how to), 425
  - user mask, 96
- dmesg command, 369
  - SPARC example, 369
  - x86 example, 370
- DOS, file system, 533
- driver not attached message, 366
- dump levels
  - daily, cumulative backups, 661
  - daily, discrete backups, 661
  - defined, 660
- duplicate blocks, 621
- DVD-ROM, 535
- dynamic reconfiguration, 373

## E

- eject command, removable media (how to), 237
- ejecting, removable media (how to), 237
- encryption, 83
- end-of-media detection
  - cpio command, 720
  - ufsdump command, 704
- env command, 91
- environment variables
  - description, 91, 96
  - LOGNAME, 93
  - LPDEST, 93
  - PATH, 93, 95
  - SHELL, 94
  - TZ, 94
- erasing, CD-RW media (how to), 267
- /etc/dfs/dfstab file
  - configuring for shared removable media (how to), 239
  - user home directory sharing and, 108
- /etc/dumpdates file, 704
- /etc files
  - user account information and, 70, 83
- /etc/init.d directory, 166
- /etc/inittab file
  - entry description, 157
  - example of default, 158
- /etc/passwd file
  - description, 83

- /etc/passwd file (Continued)
  - fields in, 83
  - user ID number assignment and, 71
  - recovering
    - SPARC, 192
  - recovering (example of)
    - x86, 206
  - deleting user accounts and, 82
- /etc/rmmount.conf file, sharing removable media drives (how to), 239
- /etc/shadow file, description, 83
- /etc/skel directory, 89
- /etc/vfstab file, 109
- /export/home file system, 75
- /export/home directory, 539
- exporting shell variables, 92
- extended fundamental types (UFS file system), 541
- extracting, an audio track on a CD (how to), 266

## F

- FDFS file system, 537
- ff command, 537
- field replaceable unit (FRU), 122
- FIFO inodes, 620
- FIFOFS file system, 537
- file system name, 690
- file system table, virtual, 546
- file systems
  - /, 539
  - 4.3 Tahoe, 533
  - BSD Fat Fast, 533
  - cached (overview), 577
  - checking and repairing, 624
  - checking interactively, 625
  - checking size, 619
  - copying complete (dd), 717
  - creating (how to)
    - TMPFS, 554
    - UFS, 552
  - creating (overview)
    - loopback (LOFS), 556
  - custom parameters, 643
  - cylinder group struct, 639
  - damage to, 616

## file systems (Continued)

- default SunOS, 539
- description of administration
  - commands, 537
- disk-based, 533
- DOS, 533
- /export/home, 539
- FDFS, 537
- FIFOFS, 537
- finding types, 548
- fixing, 627
- High Sierra, 533
- ISO 9660, 533
- large, 561
- making available (overview), 559
- manual pages for, 538
- MNTFS, 540
- mount table, 545
- mounting NFS (how to), 569
- NAMEFS, 537
- network-based, 534
  - /opt, 540
- PCFS, 533
- preening, 626, 627
  - /proc, 540
- process, overview, 536
- PROCFs, overview, 536
- pseudo, overview, 534
- reasons for inconsistencies, 618
- restoring complete, 697
- restoring complete (how to), 697
- sharing, 547
- SPECFs, 537
- stopping all processes accessing (how to), 572
- SWAPFS, 537
- TMPFS, 535
- types of, 533
- UFS, 533
- UNIX, 533
- unmounting (how to), 573
  - /usr, 539
  - /var, 539
- which to back up, 655
- why you back up, 655

## files

- archiving to multiple diskettes with `cpio` command (how to), 736

## files (Continued)

- changing ownership for user accounts, 81
  - commands for copying to media
    - (overview), 716
  - controlling access to, 69, 96
  - copying to diskette with `tar` command (how to), 734
  - copying to tape with `cpio` command (how to), 727
  - copying to tape with `pax` command (how to), 726
  - copying to tape with `tar` command (how to), 723
    - /etc/default/fs, 548
    - /etc/dfs/fstypes, 548
    - in the /proc directory, 536
  - listing on diskette with `tar` command (how to), 735
  - listing on tape with `cpio` command (how to), 728
  - listing on tape with `tar` command (how to), 724
  - restoring interactively (how to), 693
  - restoring non-interactively (how to), 695
  - retrieving from diskette with `tar` command (how to), 735
  - retrieving from tape with `cpio` command (how to), 729, 730
  - retrieving from tape with `tar` command (how to), 724
  - sharing, 547
  - verifying attributes for newly installed packages, 323
- ## finding
- file system name, 690
  - number of tapes for a full backup (how to), 673
  - PROM revision level, 181
  - tape device name, 691
  - tape drive type, 742
  - type of file system, 548
- ## fixing inconsistent file systems, 627
- ## forget root password
- SPARC, 193
  - x86, 207
- ## format.dat file
- creating an entry (how to), 474
  - creating an entry (overview), 473



- format.dat file (Continued)
  - keywords, 513, 516
  - syntax rules, 513
- format of inodes, 620
- format utility
  - analyze menu, 510
  - automatic configuration of SCSI disk drives (how to), 476
  - automatic configuration of SCSI disk drives (overview), 474
  - creating a Solaris fdisk partition (how to), 495
  - creating disk slices and labeling disk (how to)
    - SPARC, 484
    - x86, 501
  - defect menu, 511
  - determining if a disk is formatted (how to), 463
  - displaying disk slice information (example of), 466
  - displaying disk slice information (how to), 465
  - fdisk menu, 509
  - features and benefits, 451
  - formatting a disk (example of), 464
  - formatting a disk (how to), 463
  - guidelines for using, 452
  - how to enter command names, 518
  - how to specify block numbers, 517
  - identifying disks on a system (examples of), 462
  - identifying disks on a system (how to), 460
  - input to, 517, 519
  - labeling a disk
    - example of, 468
  - labeling a disk (how to), 467
  - main menu, 506
  - overview, 450
  - partition menu, 508, 509
  - recommendations for preserving information, 505
  - recovering corrupted disk label (how to), 471
  - using help facility, 519
  - when to use, 451
- formatting a disk, overview, 453
- fragment size, 644
- free blocks, 619, 642
- free hog slice, *See* donor slice
- free inodes, 620
- free space (minimum), 644
- fsck command, 432, 537
  - checking
    - free blocks, 619
    - free inodes, 620
    - inode list size, 619
    - superblock, 619
  - conditions to repair, 618
  - FSACTIVE state flag, 616
  - FSBAD state flag, 616
  - FSCLEAN state flag, 616
  - FSSTABLE state flag, 616
  - preening, 626
  - state flags, 616
  - syntax and options, 630
  - using interactively, 624
- fsdb command, 538
- fssnap command
  - creating a UFS snapshot (how to), 684
  - deleting UFS snapshot information (how to), 685
  - displaying UFS snapshot information (how to), 684
- fstyp command, 538
- fstypes file, 548
- full backup
  - creating with the ufsdump command (how to), 674
  - definition, 658
  - determine number of tapes for (how to), 673
  - example of, 675, 677
  - to a remote system
    - example of, 678
- fuser command
  - finding if removable media is in use (how to), 236
  - killing processes accessing removable media (how to), 236

**G**

- GECOS field (passwd file), 84
- GIDs, 71
  - assigning, 77

- GIDs (Continued)
  - definition, 76
  - large, 72
- grep command, 548
- group file
  - deleting user accounts and, 82
  - description, 83
  - fields in, 86
- group ID numbers, 71, 76, 77
- groups
  - changing primary, 76
  - default, 77
  - description, 69, 76
  - description of names, 76
  - displaying groups a user belongs to, 76
  - guidelines for managing, 76, 77
  - ID numbers, 71, 76, 77
  - name services and, 77
  - names
    - description, 76
  - permissions setting for, 96
  - primary, 76, 77
  - secondary, 76, 77
  - storage of information for, 83, 86
  - UNIX, 76
- groups command, 76

## H

- halt command, 170
- header format, copying files with different with
  - cpio command (how to), 736
- High Sierra file system, 533
- history environment variable, 93
- /home (automounted), 548
- HOME environment variable, 93
- /home file system, user home directories
  - and, 75
- hot-plugging
  - adding a SCSI device to a SCSI bus (how to), 382
  - adding PCI adapter card (how to), 389
  - configuring a SCSI controller (how to), 379
  - configuring a SCSI device (how to), 380
  - connecting a SCSI controller (how to), 382
  - disconnecting a SCSI controller with `cfgadm` command (how to), 381

- hot-plugging (Continued)
  - overview, 373
  - PCI devices (overview), 388
  - removing a SCSI device (how to), 384
  - removing PCI adapter card (how to), 389
  - replacing an identical device on a SCSI controller (how to), 383
  - unconfiguring a SCSI controller (how to), 379
- HSFS, *See* High Sierra file system

## I

- I/O, direct, 542
- ID numbers
  - group, 71, 76, 77
  - user, 71, 81
- identifying
  - CD media (how to), 260
  - devices, 367
  - disks on a system (how to), 460
- inconsistencies in file systems, 618
- incorrect . and .. entries, 623
- incremental backup, 658, 705
  - example of, 676
- indirect blocks, 622
- init command
  - description, 170
  - shutting down a standalone system, 175
- init states, *See* run levels
- initialization files, system, 76
- inode list size, 619
- inode states, 620
- inodes, 640
  - bad number, 623
  - block special, 620
  - character special, 620
  - checking format and type, 620
  - directory, 620
  - FIFO, 620
  - link count, 621
  - number of bytes per, 645
  - regular, 620
  - size, 622
  - symbolic link, 620
- installboot command, 490, 503

- installing a boot block (how to)
  - SPARC, 490
  - x86, 503
- interactive
  - checking file systems, 625
  - restore (how to), 693
- ISO 9660 file system, 533
- ISO standards, 9660 CD format, 232

**J**

- Java keystore, 279

**K**

- /kernel/drv directory, 365
- key, user, *See* user key
- keystore, 275
- keytool command, 279
  - overview, 311
- killing
  - all processes accessing a file system (how to), 572
  - processes accessing removable media (how to), 236
- Korn shell
  - basic features, 91
  - environment variables and, 92, 96
  - shell (local) variables and, 92, 94
  - user initialization files and, 89, 90, 91, 97, 104
  - See* user initialization files

**L**

- L1-A keys, 190, 193
- labelit command, 538
- LANG environment variable, 93, 95, 96
- large files option, 561
- LC environment variables, 95, 96
- level 0 backup, 660
- link count of inodes, 621
- listing
  - files on a diskette with tar command (how to), 735

- listing (Continued)
  - files on a tape with cpio command (how to), 728
  - files on a tape with tar command (how to), 724
  - package information (example of), 322
- \*LK\* password, 83, 86
- loading
  - diskettes
    - with volume management, 249
  - diskettes with volume management (how to), 248
- local.cshrc file, 89
- local.login file, 89
- local.profile file, 89
- locale environment variable, 93
- locating, CacheFS log file, 600
- log (record of dumps), 704
- logical block size, 643
- logical device name
  - definition, 430
  - disk, 431
  - tape, 434
- logical device names, removable media, 435
- .login file
  - customizing, 75, 91, 97
  - description, 89
- login names (user)
  - changing, 81
  - description, 70
- LOGNAME environment variable, 93
- loopback file system (LOFS)
  - creating (overview), 556
  - mounting, 565
- lost+found directory, 616
- LPDEST environment variable, 93

**M**

- magnetic tape cartridge
  - retensioning, 743
  - rewinding, 744
- mail aliases, user login names vs., 71
- MAIL environment variable, 92, 93
- maintaining tape drives, 744
- MANPATH environment variable, 93
- manual mounting, remote media (how to), 241

- manual pages, for file systems, 538
- maximum, USB device support, 402
- maximums
  - secondary groups users can belong to, 76
  - user ID number, 71
  - user login name length, 70
  - user password length, 74
- media was found message, 249
- memory storage (virtual), definition, 606
- minimum free space, 644
- minimums
  - user login name length, 70
  - user password length, 74
- mkfile command, 611, 612
- mkfs command, 538, 552
- mkisofs command, create a data CD file
  - system (how to), 262
- MNTFS file system, 540
- mnttab file, 545
- monitor (PROM), 213
- mount command, 432
- mount point, definition, 543
- mount table, 545
- mountall command, 538
- mounting
  - a file system with `/etc/vfstab`, 566
  - all files in `vfstab` file, 565
  - diskettes on other systems (example of), 242
  - file systems automatically, 547
  - loopback file systems (LOFS), 565
  - NFS file systems, 565
  - NFS file systems (how to), 569
  - PCMCIA memory cards on other systems (example of), 243
  - remote media (how to), 241
  - remote removable media manually (example of), 242
  - removable media
    - automatic mounting compared to, 227
  - UFS file systems, 565
  - UFS file systems (how to)
    - without large files, 568
  - USB mass storage devices with `vold` running (how to), 415
  - USB mass storage devices without `vold` running (how to), 415
  - user home directories
    - automounting, 76

- mounting, user home directories (Continued)
  - remote, 108
  - user home directories (how to), 109
  - using default options, 567
- mt command, 743
- multiple versions of software packages, 282, 284
- multiuser level, *See* run level 3

## N

- name services
  - groups and, 77
  - user accounts and, 70, 83
- NAMEFS file system, 537
- names
  - group
    - description, 76
    - software package naming conventions, 282
    - SUNW prefix, 282
    - user login
      - changing, 81
      - description, 69, 70
- ncheck command, 538
- network-based file systems, 534
- newfs command, 432, 552, 646
- newgrp command, 76
- NFS
  - description, 547
  - server description, 547
  - `vfstab` entry for, 565
- nfsd daemon
  - starting, 239
  - verifying if running, 238
- NIS
  - user accounts and, 70, 83
- NIS+
  - groups and, 77
  - user accounts and, 70, 83
- no media was found message, 249
- noaccess user/group, 71, 87
- noask\_pkgadd administration file, 283, 319
- nobody user/group, 71, 87
- notifying users of system down time, 171
- NP password, 86

## O

- /opt directory, 540
- optimization type, 645
- options, for `ufsdump` command, 708
- OS server, description, 126
- other (permissions setting), 96

## P

- package keystore, setting up, 279
- packages
  - adding
    - See also* `pkgadd` command
  - definition of, 274
  - overview, 274
  - signed
    - See* packages, signed
- packages, signed
  - adding, 315
  - displaying certificate information, 313
  - importing a trusted certificate, 311
  - overview, 275
  - removing a certificate, 314
- parameters (file system), 643
- partition (swap), definition, 606
- `passwd` file, 83
  - deleting user accounts and, 82
  - fields in, 83, 84
  - recovering
    - SPARC, 192
  - recovering (example of)
    - x86, 206
  - restoring from tape (example of), 696
  - user ID number assignment and, 71
- passwords (user)
  - aging, 74, 82, 83
  - changing
    - frequency of, 74, 86
    - by user, 74
    - Users Tool, 82
  - choosing, 74
  - description, 69, 74
  - disabling/locking user accounts and, 83, 86
  - encryption, 83
  - expiration, 86
  - NP password, 86
  - \*LK\* password, 83, 86

- passwords (user) (Continued)
  - precautions, 74
  - setting, 74, 82
  - Users Tool, 82
- `patchadd` command
  - adding a signed patch (how to), 342
  - adding unsigned patches, 358
  - signed patches and, 272
- patches
  - accessing from the world wide web, 331
  - availability for Sun Service customers, 330
  - definition, 329
  - disk space requirements, 338
  - finding already installed, 357
  - general availability, 331
  - installation README, 332
  - managing, 337
  - numbering scheme, 331
  - removing, 359
  - signed, 272
    - adding, 275
    - definition, 330
    - tools and commands (overview), 332
    - where to find, 331
- patches, signed, *See* patches
- PatchPro, keystore, 279
- `patchrm` command, 359
- `PATH` environment variable
  - description, 93, 94
  - setting up, 94, 95
- `path` shell variable, 92
- PC BIOS (and booting), 214
- PCFS file system, 533
- PCI devices
  - adding PCI adapter card (how to), 389
  - displaying PCI device information (how to), 388
  - removing PCI adapter card (how to), 389
  - troubleshooting PCI configuration
    - problems, 391
- PCMCIA memory cards
  - accessing on other systems (example of), 243
  - mounting remotely (example of), 243
- PEM (Privacy Enhanced Message), 276
- permissions, 96
- physical device name, definition, 430
- PKCS7 (Public Key Cryptography Standard #7), 276

- /pkg directory, 321
- pkgadd command
  - d option (device name), 317, 318, 319, 320, 321
  - s option (spool directory), 320, 321
  - adding a signed package, 315
  - adding packages (how to), 317
    - using an HTTP URL, 319
  - alternate base directory and, 284
  - bypassing user interaction, 283, 284
  - overview, 280, 285
  - a option (administration file), 283, 284, 317, 319
  - prerequisites for using, 281
  - signed packages and, 272
  - spool directories and, 320
  - spool directories and (example of), 321
- pkgadm addcert command, *See* pkgadm command
- pkgadm command
  - overview, 285
  - pkgadm addcert command
    - importing a trusted certificate, 311
    - overview, 311
  - pkgadm listcert command
    - displaying certificate information, 313
    - output, 276
    - overview, 311
  - pkgadm removecert command
    - overview, 311
    - removing a certificate, 314
- pkgadm listcert command, *See* pkgadm command
- pkgadm removecert command, *See* pkgadm command
- pkgchk command
  - overview, 285
  - using (example of), 323
- pkginfo command
  - displaying all packages installed (example of), 322
  - how to use, 321
  - overview, 282, 285
- pkgparam command, overview, 285
- pkgrm command
  - caution, 282, 324
  - overview, 280, 285, 324
  - prerequisites for using, 281
- pkgrm command (Continued)
  - removing a package (how to), 324
  - rm command vs., 282, 324
- pkgtrans command, overview, 285
- PKI (Public Key Infrastructure) site, 279
- playing musical CD or DVD, 235
- preening file systems, 626, 627
- preparing
  - for backing up (overview), 672
  - to restore files (overview), 690
- Primary Administrator role
  - assuming (how to), 53
  - creating (how to), 53
  - creating (overview), 52
- primary groups, 76, 77
- /proc directory, 536, 540
- process file system (PROCFS), 536
- PROCFS file system, overview, 536
- prodreg command, 272
  - checking dependencies between software products (how to), 298
  - identifying damaged software (how to), 299
  - listing information about installed products (how to), 293
  - listing software attributes (how to), 296
  - overview, 285, 293
  - reinstalling damaged software (how to), 309
  - uninstalling damaged software (how to), 306
  - uninstalling software (how to), 302
- Product Registry
  - adding software with, 288
  - checking dependencies between software products (how to), 298
  - identifying damaged software (how to), 299
  - installing software with (how to), 290
  - listing information about installed products (how to), 290, 293
  - listing software attributes (how to), 296
  - purpose, 288
  - reinstalling damaged software (how to), 309
  - removing software with, 288
  - uninstalling damaged software (how to), 306
  - uninstalling software (how to), 302
  - uninstalling software with (how to), 291
- .profile file
  - customizing, 75, 91, 97

- .profile file (Continued)
  - description, 89
- PROM
  - changing boot-from setting, 183
  - finding revision level, 181
  - finding the ROM revision, 181
  - monitor, 213
- prompt shell variable, 93
- prtconf command, 368
- prtvtop command, 432
  - example of using, 469
- PS1 environment variable, 93
- pseudo file systems, overview, 534
- pseudo-ttys, 71
- pseudo user logins, 71

**R**

- raw disk device interface, 431, 432
- reboot command, 170
- reconfiguration boot, 475
  - SPARC example, 484
  - x86 example, 493
- record of
  - dumps, 704
  - incremental backup, 705
- recover root password (how to)
  - SPARC, 193
  - x86, 207
- regular inodes, 620
- remote drive (restoring from), 696
- remote mounting, 108
- remote package server
  - adding packages to a spool directory (example of), 321
  - software installation from, 319
  - software installation from (example of), 318
- removable media
  - accessing (examples of), 234
  - accessing (how to), 233
  - accessing media on other systems (example of), 242
  - accessing media on other systems (how to), 241
  - copying information (how to), 234
  - ejecting (how to), 237
  - finding out if media is in use (how to), 236

- removable media (Continued)
  - killing processes accessing (how to), 236
  - making available to other systems (how to), 238
  - mounting
    - manual compared to automatic, 227
    - mounting remote media (example of), 242
    - mounting remote media (how to), 241
  - musical CD or DVD, 235
  - names, 230
  - preparing for new drive (how to), 232
- removef command, 282
- removing
  - a SCSI device (how to), 384
  - a swap file from use, 613
  - packages with administration files and, 283
  - PCI adapter card (how to), 389
  - software packages
    - guidelines for, 282
    - software packages (how to), 324
    - software with Solaris Product Registry, 288
  - unused USB audio device links (how to), 422
  - USB mass storage device with vold running, 412
  - USB mass storage device without vold running, 412
- repairing the /etc/passwd file
  - SPARC, 192
  - x86, 206
- replacing, an identical device on a SCSI controller (how to), 383
- reset command, 185
- resetting
  - a SPARC based system, 185
  - a USB device (how to), 428
- resolving, a failed SCSI unconfigure operation (how to), 387
- restoring bad superblock, 628
- restoring file systems
  - complete (example), 698
  - complete (example of), 697
  - determining which tapes to use (how to), 692
  - preparing to (overview), 690
  - root and /usr (how to), 700
  - root and /usr (SPARC) (example of), 701
  - root and /usr (x86) (example of), 702

- restoring file systems (Continued)
  - type of tape drive, 691
- restoring files
  - example of interactive restore, 694
  - example of non-interactive restore, 696
  - from remote drive (example of), 696
  - interactively (how to), 693
  - non-interactively (how to), 695
- restricting, removable media access (how to), 260
- retensioning magnetic tape cartridge, 743
- retrieving
  - files created with `bar` command (how to), 737
  - files from a tape with `cpio` command (how to), 729
  - files from diskette with `tar` command (how to), 735
  - files from remote tape with `tar` and `dd` commands (how to), 732
  - files from tape with `tar` command (how to), 724
  - specific files from tape with `cpio` command (how to), 730
- revision level of PROM, 181
- rewinding magnetic tape cartridge, 744
- `rmmount.conf` file, sharing removable media drives (how to), 239
- Rock Ridge extension (HSFS file system), 533
- root (/) file system, 539
- root (superuser), becoming, 48
- root password, forget
  - SPARC, 193
  - x86, 207
- run control scripts, 160
  - adding (how to), 166
  - disabling (how to), 167
  - starting and stopping services, 165
- run level
  - 0 (power-down level), 156
  - 1 (single-user level), 156
  - 2 (multiuser level), 156
  - 3 (multiuser with NFS), 156
    - booting to, 186, 199
    - processes executed at, 159
    - what happens when system is brought to, 159
  - 6 (reboot level), 156

- run level (Continued)
  - default run level, 155
  - definition, 155
  - determining (how to), 156
  - s or S (single-user level), 156
    - booting to, 200
  - s or S (single-user state)
    - booting to, 187

## S

- `/sbin/rc0` script, 161
- `/sbin/rc1` script, 161
- `/sbin/rc2` script, 162
- `/sbin/rc3` script, 164
- `/sbin/rc5` script, 164
- `/sbin/rc6` script, 164
- `/sbin/rcS` script, 164
- scheduling backups, 660
- SCSI devices
  - adding a SCSI device to a SCSI bus (how to), 382
  - configuring with `cfgadm` command (how to), 380
  - connecting with `cfgadm` command (how to), 382
  - disconnecting with `cfgadm` command (how to), 381
  - displaying with `cfgadm` command (how to), 378
  - removing with `cfgadm` command (how to), 384
  - replacing an identical device on a SCSI controller (how to), 383
  - resolving a failed SCSI unconfigure operation (how to), 387
  - troubleshooting SCSI configuration problem, 385
  - unconfiguring with `cfgadm` command (how to), 379
- SCSI disk drives, 474
- SCSI tape drives, 741
- secondary disk
  - connecting to the system (how to)
    - SPARC, 484
    - x86, 494
  - description, 449



- secondary groups, 76, 77
- security, user ID number reuse and, 71
- servers
  - description, 120
  - OS server, 126
- set command, 92
- setenv command, 92
- setting up, CacheFS logging, 600
- shadow file
  - description, 83
  - fields in, 85, 86
- share command, 547
  - making removable media available to other systems (how to), 239
- shareall command, 547
- sharing
  - files, 547
  - removable media (how to), 238
  - user home directories, 108
  - user home directories (how to), 107
- SHELL environment variable, 94
- shell variables, 92, 94
- shells
  - basic features, 91
  - environment of, 91, 94
  - environment variables and, 91, 92, 96
  - local variables, 92, 94
  - user initialization files and, 88, 90, 91, 97, 104
- shutdown command
  - description, 170
  - notifying users, 171
  - shutting down a server, 150
  - shutting down a server (how to), 172
- shutting down
  - a server (how to), 171
  - a standalone system (how to), 175
  - a system, guidelines, 149
  - a system cleanly with shutdown and init commands, 170
- signed patches
  - See also* patches
  - adding with patchadd (how to), 342
  - best methods for adding, 334
  - downloading (how to), 341
- single-user level, *See* run level s or S
- site initialization files, 90
- size
  - checking file system, 619
  - fragment, 644
  - inode, 622
  - /skel directory, 89
  - skeleton directories (/etc/skel), 75, 82
  - slice (defined), 445
  - smpatch command, 272
    - downloading and installing (how to), 346
    - key points, 344
    - package requirements, 333
    - preparation for adding signed patches, 343
    - verifying package requirements (how to), 345
- software management
  - naming conventions for packages, 282
  - packages and, 274
  - tools for, 280
- software packages
  - installing, 321
  - installing from a spool directory (example of), 320
- Solaris Device Configuration Assistant, overview, 198
- Solaris fdisk partition, guidelines, 494
- Solaris Management Console
  - description, 41
  - description of tools, 42
  - reasons for using, 44
  - starting (how to), 54
  - using with RBAC, 50
- Solaris Product Registry
  - adding software with, 288
  - checking dependencies between software products (how to), 298
  - identifying damaged software (how to), 299
  - installing software with (how to), 290
  - listing information about installed products (how to), 290
  - listing software attributes (how to), 296
  - purpose, 288
  - reinstalling damaged software (how to), 309
  - removing software with, 288
  - uninstalling damaged software (how to), 306
  - uninstalling software (how to), 302
  - uninstalling software with (how to), 291

- Solaris User Registration, *See* User Registration
- Solaris Web Start, adding software with (how to), 287
- space optimization type, 645
- SPARC based systems, UFS format, 232
- SPECFS file system, 537
- specifying a disk slice, 432, 434
- spool directories
  - installing software packages to (example of), 321, 323
  - installing software packages to (how to), 320
- staff group, 77
- standalone systems, definition, 121
- starting
  - nfsd daemon, 239
  - volume management (how to), 233
- starting and stopping services, 165
- state flag
  - fsck, 616
  - UFS file systems, 541
- Stop-A keys, 190, 193
- stopping
  - a system for recovery purposes
    - SPARC, 190
  - a system for recovery purposes (how to)
    - x86, 204
  - all processes for a file system (how to), 572
  - CacheFS logging, 601
  - killing processes accessing removable media (how to), 236
  - volume management (how to), 233
- storage (virtual memory), definition, 606
- storage capacities (media), 658, 739
- structure of cylinder groups, 639
- stty command, 95
- Sun software packages
  - adding (example of), 318
  - installing, 319
- SunOS default file system, 539
- SunSolve, trusted certificates and, 279
- SUNW prefix, 282
- superblock, 619, 628, 640
- superuser (root), becoming, 48
- superuser (root) password, forget
  - SPARC, 193
  - x86, 207
- support for servers and clients, description, 119
- swap command, 611

- swap file
  - adding to `vfstab`, 609
  - creating, 611
  - displaying, 610
  - removing from use, 613
- swap partition, definition, 606
- swapadd command, 609
- SWAPFS file system, 537
- symbolic links, 620
- sync command, 193, 194
- synchronize file systems with sync
  - command, 194
- synchronize the file systems with sync
  - command, 193
- syntax
  - fsck command, 630
  - newfs, 646
- sysdef command, 368
- system accounts, 71
- system disk
  - connecting (how to)
    - SPARC, 483
    - x86, 493
  - description, 449
  - installing a boot block on (how to)
    - SPARC, 490
    - x86, 503
- system initialization files, 76
- system shutdown commands, 170
- system types
  - appliance, 122
  - AutoClient, 122
  - diskless client, 121
  - guidelines for choosing, 122
  - overview, 120
  - server, 120
  - standalone system, 121

## T

- tape, 744
  - capacity, 707
  - characteristics, 707
  - copying all files in a directory with `cpio` command (how to), 727
  - listing files with `tar` command (how to), 724

- tape (Continued)
    - retrieving files from with `cpio` command (how to), 729
    - retrieving files from with `tar` command (how to), 724
    - retrieving specific files from with `cpio` command (how to), 730
    - sizes, 658, 739
    - storage capacities, 658, 739
  - tape (magnetic cartridge), retensioning, 743
  - tape devices (naming), 434
  - tape drive
    - determining type for restore, 691
    - finding type, 742
    - maintaining, 744
    - maximum SCSI, 741
    - restoring from remote (example of), 696
    - rewind, 741
  - `tar` command
    - copying files to a single diskette (how to), 734
    - copying files to remote tape with `dd` command (how to), 731
    - copying files to tape (how to), 723
    - listing files on diskette (how to), 735
    - listing files on tape (how to), 724
    - overview, 723
    - retrieving files from diskette (how to), 735
    - retrieving files from remote tape with `dd` command (how to), 732
    - retrieving files from tape (how to), 724
  - temporary file system (TMPFS), overview, 535
  - TERM environment variable, 94
  - TERMINFO environment variable, 94
  - time (optimization type), 645
  - time zone environment variable, 94
  - `/tmp` directory, 536, 540
  - TMPFS file system
    - creating (how to), 554
    - overview, 535
  - troubleshooting
    - `cachefspack` errors, 594
    - diskless client problems, 141
    - PCI configuration problems, 391
    - SCSI configuration problems, 385
    - USB audio device problems, 422
  - `ttys` (pseudo), 71
  - `ttytype` pseudo user logins, 71
  - turn off power to all devices, how to, 177
  - type of file systems, 533
  - type of inodes, 620
  - type of tape drive, 742
  - TZ environment variable, 94
- ## U
- UDF file system, 535
  - UFS CDs, SPARC vs. x86 formats, 232
  - UFS file system, 533, 540
    - creating (how to), 552
    - extended fundamental types, 541
    - large file systems, 541
    - mounting, 565
    - mounting with `/etc/vfstab`, 566
    - mounting with `mount` command, 567
    - mounting without large files (how to), 568
    - state flags, 541
    - unmounting (how to), 573
  - UFS logging, overview, 541
  - UFS snapshot
    - backing up with the `tar` command (how to), 688
    - creating (how to), 684
    - creating a full backup of, 687
    - creating a full backup of (howto), 686
    - creating an incremental backup of (how to), 687
    - deleting (how to), 685
    - description, 682
    - displaying (how to), 684
  - `ufsdump` command
    - backing up file systems to tape (how to), 674
    - end-of-media detection, 704
    - full backup example, 675, 677
    - full backup to remote system
      - example of, 678
      - how data is copied with, 704
      - how it works, 703
    - incremental backup example, 676
    - limitations, 707
    - options and arguments, 708
  - `ufsdump` command (overview), 674
  - `ufsrestore` command, 711
    - determining which tapes to use (how to), 692

- ufsrestore command (Continued)
  - interactive restore (how to), 693
  - non-interactive restore (how to), 695
  - preparing to use (overview), 690
  - restoring a complete file system (how to), 697
  - restoring from a remote tape drive (example of), 696
  - restoring root (/) and /usr file systems (how to), 700
- UIDs, 81
  - assigning, 71
  - definition, 71
  - large, 72
- umask command, 96
- umount command, 538
- umountall command, 538
- unallocated directory blocks, 623
- unallocated inodes, 620
- unconfiguring
  - a SCSI controller with cfgadm command (how to), 379
  - a USB device (how to), 426
- UNIX file system, 533
- UNIX groups, 76
- unmounting
  - file systems (how to), 573
  - USB mass storage devices with vold running (how to), 415
  - USB mass storage devices without vold running (how to), 415
- unsupported devices, 365, 366
- USB camera, adding (how to), 415
- USB devices
  - acronyms, 403
  - adding a USB camera (how to), 415
  - adding a USB mass storage device
    - with vold running, 411
    - without vold running, 411
  - audio
    - adding a, 418
    - changing the primary device (how to), 420
    - device ownership, 423
    - identifying primary device (how to), 419
    - overview of, 417
    - removing unused device links (how to), 422
  - USB devices (Continued)
    - bus description, 403
    - composite device, 404
    - compound device, 404
    - configuring a USB device (how to), 427
    - connect a USB device (how to), 428
    - connect a USB device subtree (how to), 428
    - device classes, 405
    - device nodes, 405
    - displaying device information (how to), 425
    - drivers, 405
    - host controller and root hub, 407
    - hot-plugging (overview), 410
    - keyboards and mouse devices, 406
    - maximum devices supported, 402
    - mounting mass storage device without vold running \*how to), 415
    - mounting mass storage with vold running (how to), 414
    - names of, 404
    - overview, 402
    - physical device hierarchy, 403
    - power management, 408
    - removing a mass storage device
      - with vold running, 412
    - removing a USB mass storage device
      - without vold running, 412
    - resetting a USB device (how to), 428
    - Solaris USB Architecture (USBA), 405
    - storage devices, 410
    - supported, 402
    - troubleshooting audio device problems, 422
    - unconfiguring a USB device (how to), 426
    - unmounting mass storage device without vold running (how to), 415
    - unmounting mass storage with vold running (how to), 414
- user accounts, 69
  - description, 69
  - disabling/locking
    - passwords and, 83, 86
    - Users Tool, 83
  - guidelines for, 70, 76
  - ID numbers, 71, 81
  - login names, 69, 70, 81
  - name services and, 70, 83
  - setting up
    - information sheet, 102

- user accounts (Continued)
  - storage of information for, 70, 83
- user home directories
  - changing ownership of, 81
  - customized initialization files in, 75, 82
  - deleting, 82
  - description, 69, 75
  - mounting
    - automounting, 76
    - remote, 108
  - mounting (how to), 109
  - nonlocal reference to (\$HOME), 75, 90
  - sharing, 108
  - sharing (how to), 107
- user ID numbers, 71, 81
- user initialization files
  - Bourne shell, 88
  - customizing, 88, 97
    - adding customized files, 82
    - avoiding local system references, 90
    - environment variables, 92, 96
    - overview, 75, 88, 89
    - shell variables, 92, 94
    - site initialization files, 90
    - user mask setting, 96
  - customizing (how to), 103
  - default, 89
  - description, 69, 75, 76, 88
  - examples, 97
  - shells and, 88, 90, 91, 97
- user key, 275
- user login names
  - changing, 81
  - description, 69, 70
- user logins (pseudo), 71
- user mask, 96
- User Registration
  - description, 111
  - disabling, 113
  - problems, 112
  - solregis command, 111
- Users Tool
  - disabling accounts, 83
  - password administration, 82
- /usr file system, 539
- uucp group, 71

## V

- /var directory, 539
- /var/sadm/install/admin directory, 283
- /var/sadm/patch, 358
- /var/spool/pkg directory, 320, 321
- variables
  - environment, 91, 96
  - shell (local), 92, 94
- verifying
  - nfsd daemon is running, 238
  - software installation (example of), 323
  - software package installation
    - pkginfo command, 320
    - software package installation with pkginfo command, 320
- vfstab file, 548, 609
  - adding entries to (how to), 565
  - adding swap to, 609
  - default, 546
  - entry for LOFS, 557
  - finding file system names in, 672
  - mounting all files, 565
- viewing
  - CacheFS statistics, 602
  - working set (cache) size, 601
- virtual file system table, 546
- virtual memory storage, definition, 606
- volcopy command, 538
- volmgt start command, 233
- volume management
  - benefits, 226
  - diskettes
    - loading, 249
  - loading diskettes (how to), 248
  - manual compared to automatic mounting, 227
  - removable media
    - accessing, 228
  - restarting (how to), 233
  - stopping (how to), 233

## W

- when to turn off power to devices, 176
- who command, 156, 171
- world (permissions), 96
- writing, data and audio CDs (overview), 259

**X**

X.509, 276

x86 based systems, UFS format, 232